



Online Continuing Education for Professional Engineers
Since 2009

Solar Power Towers

PDH Credits:

2 PDH

Course No.:

SPT101

Publication Source:

US Dept. of Energy

DISCLAIMER:

All course materials available on this website are not to be construed as a representation or warranty on the part of Online-PDH, or other persons and/or organizations named herein. All course literature is for reference purposes only, and should not be used as a substitute for competent, professional engineering council. Use or application of any information herein, should be done so at the discretion of a licensed professional engineer in that given field of expertise. Any person(s) making use of this information, herein, does so at their own risk and assumes any and all liabilities arising therefrom.

SOLAR POWER TOWER

1.0 System Description

Solar power towers generate electric power from sunlight by focusing concentrated solar radiation on a tower-mounted heat exchanger (receiver). The system uses hundreds to thousands of sun-tracking mirrors called heliostats to reflect the incident sunlight onto the receiver. These plants are best suited for utility-scale applications in the 30 to 400 MW_e range.

In a molten-salt solar power tower, liquid salt at 290°C (554°F) is pumped from a ‘cold’ storage tank through the receiver where it is heated to 565°C (1,049°F) and then on to a ‘hot’ tank for storage. When power is needed from the plant, hot salt is pumped to a steam generating system that produces superheated steam for a conventional Rankine-cycle turbine/generator system. From the steam generator, the salt is returned to the cold tank where it is stored and eventually reheated in the receiver. Figure 1 is a schematic diagram of the primary flow paths in a molten-salt solar power plant. Determining the optimum storage size to meet power-dispatch requirements is an important part of the system design process. Storage tanks can be designed with sufficient capacity to power a turbine at full output for up to 13 hours.

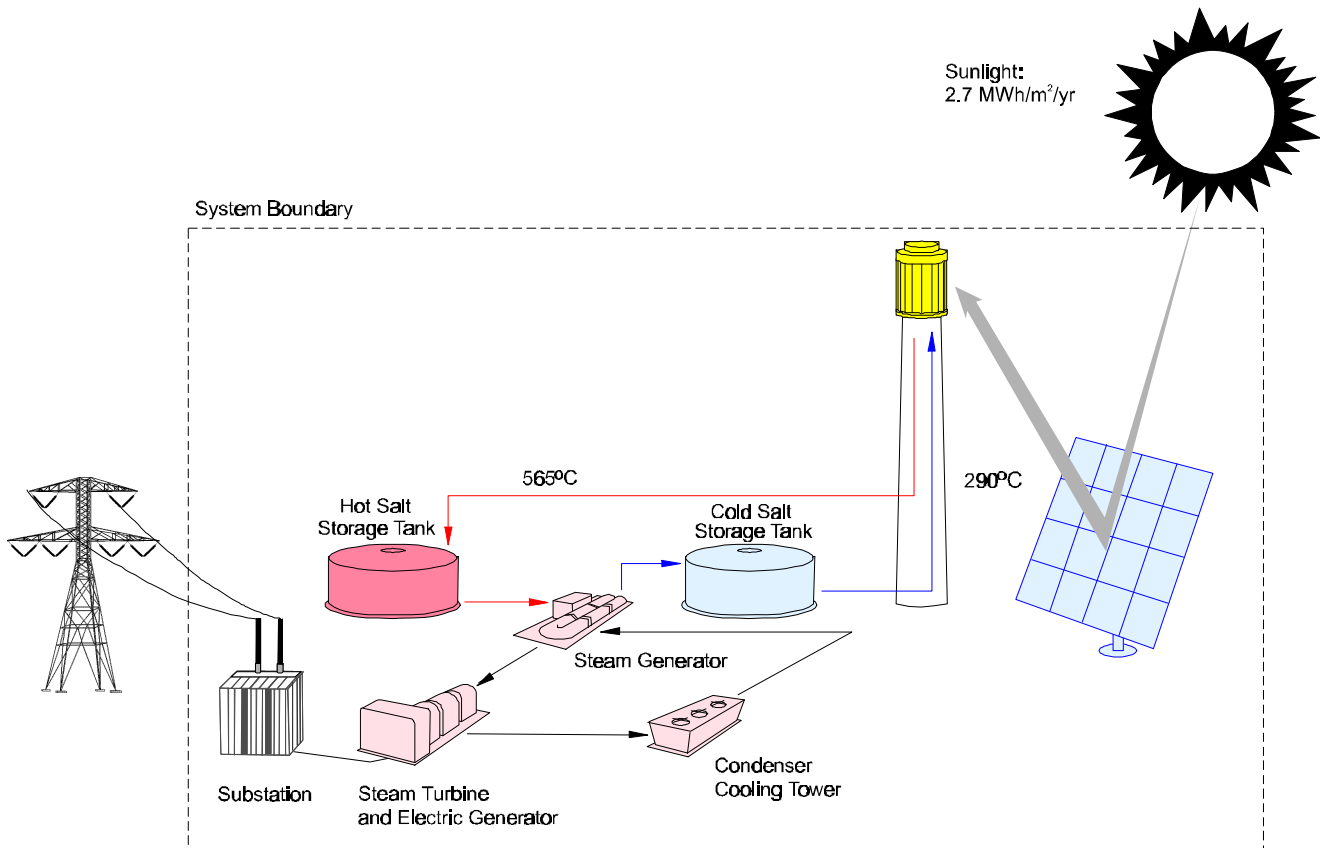

Figure 1. Molten-salt power tower system schematic (Solar Two, baseline configuration).

The heliostat field that surrounds the tower is laid out to optimize the annual performance of the plant. The field and the receiver are also sized depending on the needs of the utility. In a typical installation, solar energy collection occurs at a rate that exceeds the maximum required to provide steam to the turbine. Consequently, the thermal storage system can be *charged* at the same time that the plant is producing power at full capacity. The ratio of the thermal power

SOLAR POWER TOWER

provided by the collector system (the heliostat field and receiver) to the peak thermal power required by the turbine generator is called the solar multiple. With a solar multiple of approximately 2.7, a molten-salt power tower located in the California Mojave desert can be designed for an annual capacity factor of about 65%. (Based on simulations at Sandia National Laboratories with the SOLERGY [1] computer code.) Consequently, a power tower could potentially operate for 65% of the year without the need for a back-up fuel source. Without energy storage, solar technologies are limited to annual capacity factors near 25%.

The dispatchability of electricity from a molten-salt power tower is illustrated in Figure 2, which shows the load-dispatching capability for a typical day in Southern California. The figure shows solar intensity, energy stored in the hot tank, and electric power output as functions of time of day. In this example, the solar plant begins collecting thermal energy soon after sunrise and stores it in the hot tank, accumulating energy in the tank throughout the day. In response to a peak-load demand on the grid, the turbine is brought on line at 1:00 PM and continues to generate power until 11 PM. Because of the storage, power output from the turbine generator remains constant through fluctuations in solar intensity and until all of the energy stored in the hot tank is depleted. Energy storage and dispatchability are very important for the success of solar power tower technology, and molten salt is believed to be the key to cost effective energy storage.

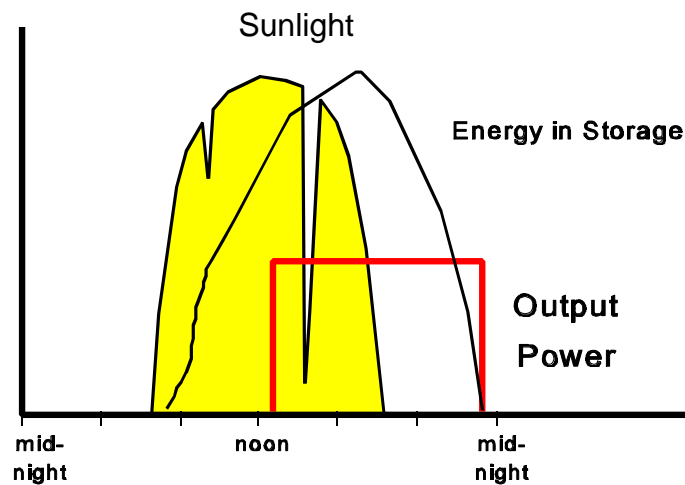

Figure 2. Dispatchability of molten-salt power towers.

Power towers must be large to be economical. Power tower plants are not modular and can not be built in the smaller sizes of dish/Stirling or trough-electric plants and be economically competitive, but they do use a conventional power block and can easily dispatch power when storage is available. In the United States, the Southwest is ideal for power towers because of its abundant high levels of insolation and relatively low land costs. Similar locations in northern Africa, Mexico, South America, the Middle East, and India are also well-suited for power towers.

History

Although power towers are commercially less mature than parabolic trough systems, a number of component and experimental systems have been field tested around the world in the last 15 years, demonstrating the engineering feasibility and economic potential of the technology. Since the early 1980s, power towers have been fielded in Russia,

SOLAR POWER TOWER

Italy, Spain, Japan, France, and the United States [2]. In Table 1, these experiments are listed along with some of their more important characteristics. These experimental facilities were built to prove that solar power towers can produce electricity and to prove and improve on the individual system components. Solar Two, which is currently going through its startup phase, will generate (in addition to electric power) information on the design, performance, operation and maintenance of molten-salt power towers. The objective of Solar Two is to mitigate the perceived technological and financial risks associated with the first commercial plants and to prove the molten-salt thermal storage technology.

Table 1. Experimental power towers.

Project	Country	Power Output (MWe)	Heat Transfer Fluid	Storage Medium	Operation Began
SSPS	Spain	0.5	Liquid Sodium	Sodium	1981
EURELIOS	Italy	1	Steam	Nitrate Salt/Water	1981
SUNSHINE	Japan	1	Steam	Nitrate Salt/Water	1981
Solar One	USA	10	Steam	Oil/Rock	1982
CESA-1	Spain	1	Steam	Nitrate Salt	1983
MSEE/Cat B	USA	1	Molten Nitrate	Nitrate Salt	1984
THEMIS	France	2.5	Hi-Tec Salt	Hi-Tec Salt	1984
SPP-5	Russia	5	Steam	Water/ Steam	1986
TSA	Spain	1	Air	Ceramic	1993
Solar Two	USA	10	Molten Nitrate Salt	Nitrate Salt	1996

In early power towers, the thermal energy collected at the receiver was used to generate steam directly to drive a turbine generator. Although these systems were simple, they had a number of disadvantages that will be described in the discussions that follow.

Solar One

Solar One, which operated from 1982 to 1988, was the world's largest power tower plant. It proved that large-scale power production with power towers was feasible. In that plant, water was converted to steam in the receiver and used directly to power a conventional Rankine-cycle steam turbine. The heliostat field consisted of 1818 heliostats of 39.3 m² reflective area each. The project met most of its technical objectives by demonstrating (1) the feasibility of generating power with a power tower, (2) the ability to generate 10 MW_e for eight hours a day at summer solstice and four hours a day near winter solstice. During its final year of operation, Solar One's availability during hours of sunshine was 96% and its annual efficiency was about 7%. (Annual efficiency was relatively low because of the plant's small size and the inclusion of non-optimized subsystems.)

The Solar One thermal storage system stored heat from solar-produced steam in a tank filled with rocks and sand using oil as the heat-transfer fluid. The system extended the plant's power-generation capability into the night and provided heat for generating low-grade steam for keeping parts of the plant warm during off-hours and for morning startup. Unfortunately, the storage system was complex and thermodynamically inefficient. While Solar One successfully demonstrated power tower technology, it also revealed the disadvantages of a water/steam system, such as the intermittent operation of the turbine due to cloud transience and lack of effective thermal storage.

During the operation of Solar One, research began on the more advanced molten-salt power tower design described previously. This development culminated in the Solar Two project.

SOLAR POWER TOWER

Solar Two

To encourage the development of molten-salt power towers, a consortium of utilities led by Southern California Edison joined with the U.S. Department of Energy to redesign the Solar One plant to include a molten-salt heat-transfer system. The goals of the redesigned plant, called Solar Two, are to validate nitrate salt technology, to reduce the technical and economic risk of power towers, and to stimulate the commercialization of power tower technology. Solar Two has produced 10 MW of electricity with enough thermal storage to continue to operate the turbine at full capacity for three hours after the sun has set. Long-term reliability is next to be proven.

The conversion of Solar One to Solar Two required a new molten-salt heat transfer system (including the receiver, thermal storage, piping, and a steam generator) and a new control system. The Solar One heliostat field, the tower, and the turbine/generator required only minimal modifications. Solar Two was first attached to a utility grid in early 1996 and is scheduled to complete its startup phase in late 1997.

The Solar Two receiver was designed and built by Boeing's Rocketdyne division. It comprises a series of panels (each made of 32 thin-walled, stainless steel tubes) through which the molten salt flows in a serpentine path. The panels form a cylindrical shell surrounding piping, structural supports, and control equipment. The external surfaces of the tubes are coated with a black Pyromark™ paint that is robust, resistant to high temperatures and thermal cycling, and absorbs 95% of the incident sunlight. The receiver design has been optimized to absorb a maximum amount of solar energy while reducing the heat losses due to convection and radiation. The design, which includes laser-welding, sophisticated tube-nozzle-header connections, a tube clip design that facilitates tube expansion and contraction, and non-contact flux measurement devices, allows the receiver to rapidly change temperature without being damaged. For example, during a cloud passage, the receiver can safely change from 290 to 570°C (554 to 1,058°F) in less than one minute.

The salt storage medium is a mixture of 60 percent sodium nitrate and 40 percent potassium nitrate. It melts at 220°C (428°F) and is maintained in a molten state (290°C/554°F) in the 'cold' storage tank. Molten salt can be difficult to handle because it has a low viscosity (similar to water) and it wets metal surfaces extremely well. Consequently, it can be difficult to contain and transport. An important consideration in successfully implementing this technology is the identification of pumps, valves, valve packing, and gasket materials that will work with molten salt. Accordingly, Solar Two is designed with a minimum number of gasketed flanges and most instrument transducers, valves, and fittings are welded in place.

The energy storage system for Solar Two consists of two 875,000 liter storage tanks which were fabricated on-site by Pitt-Des Moines. The tanks are externally insulated and constructed of stainless steel and carbon steel for the hot and cold tanks, respectively. Thermal capacity of the system is 110 MWh_t. A natural convection cooling system is used in the foundation of each tank to minimize overheating and excessive dehydration of the underlying soil.

All pipes, valves, and vessels for hot salt were constructed from stainless steel because of its corrosion resistance in the molten-salt environment. The cold-salt system is made from mild carbon steel. The steam generator system (SGS) heat exchangers, which were constructed by ABB Lummus, consist of a shell-and-tube superheater, a kettle boiler, and a shell-and-tube preheater. Stainless steel cantilever pumps transport salt from the hot-tank-pump sump through the SGS to the cold tank. Salt in the cold tank is pumped with multi-stage centrifugal pumps up the tower to the receiver.

Solar Two is expected to begin routine daily power production in late 1997. Initial data collected at the plant show that the molten-salt receiver and thermal storage tanks should perform as predicted during design. For example, data collected on March 26, 1997, revealed that the receiver absorbed 39.8 MW_t, which is 93% of the design value. Considering the fact that the heliostat field had significant alignment problems at the time of the measurement, the receiver is expected to reach 100% of the design after realignment. This was reaffirmed by efficiency tests conducted

SOLAR POWER TOWER

in October 1997 which indicated an 87% value; this is nearly identical to the design prediction. The hot tank within the thermal storage system has also exhibited excellent thermal characteristics. Figure 3 depicts a month-long cool down of the hot storage tank when it was filled with molten salt. It can be seen that the tank cools very slowly (about 75°C/167°F over one month) and the measured thermal losses are within about 10% of the design prediction.

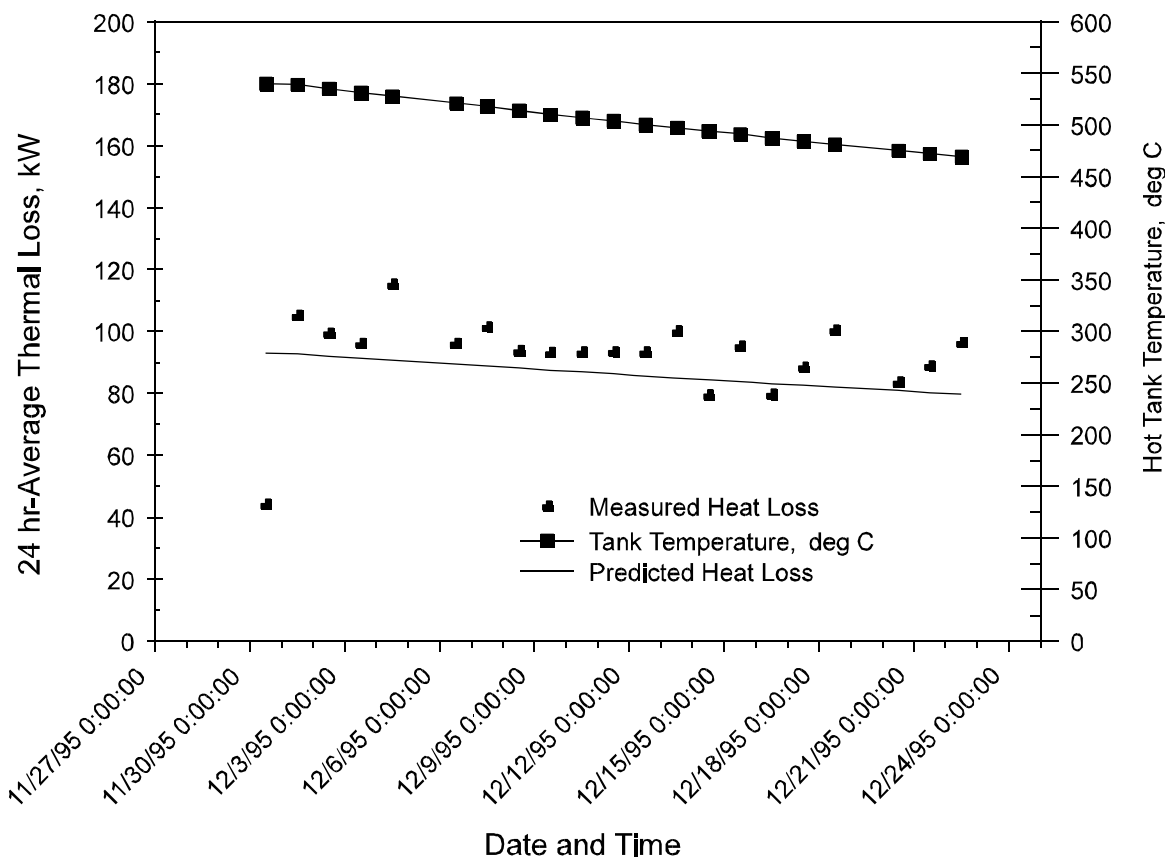

Figure 3. Cool down of hot storage tank at Solar Two.

It is important to note that at 10 MW, Solar Two is too small to be economically viable. Operation and maintenance (O&M) costs for a small solar only power tower are too high. This can be demonstrated by examining Table 3 (to be presented later). O&M costs become reasonable at 30 MW or greater system sizes. This has also been observed at the operating SEGS trough plants.

SOLAR POWER TOWER

2.0 System Application, Benefits, and Impacts

Overview

To date, the largest power towers ever built are the 10 MW Solar One and Solar Two plants. Assuming success of the Solar Two project, the next plants could be scaled-up to between 30 and 100 MW in size for utility grid connected applications in the Southwestern United States and/or international power markets. New peaking and intermediate power sources are needed today in many areas of the developing world. India, Egypt, and South Africa are locations that appear to be ideally suited for power tower development. As the technology matures, plants with up to a 400 MW rating appear feasible. As non-polluting energy sources become more favored, molten-salt power towers will have a high value because the thermal energy storage allows the plant to be dispatchable. Consequently, the value of power is worth more because a power tower plant can deliver energy during peak load times when it is more valuable. Energy storage also allows power tower plants to be designed and built with a range of annual capacity factors (20 to 65%). Combining high capacity factors and the fact that energy storage will allow power to be brought onto the grid in a controlled manner (i.e., by reducing electrical transients thus increasing the stability of the overall utility grid), total market penetration should be much higher than an intermittent solar technology without storage.

One possible concern with the technology is the relatively high amount of land and water usage. This may become an important issue from a practical and environmental viewpoint since these plants are typically deployed within desert areas that often lack water and have fragile landscapes. Water usage at power towers is comparable to other Rankine cycle power technologies of similar size and annual performance. Land usage, although significant, is typically much less than that required for hydro [3] and is generally less than that required for fossil (e.g., oil, coal, natural gas), when the mining and exploration of land are included.

Initial System Application - Hybrid Plants

To reduce the financial risk associated with the deployment of a new power plant technology and to lower the cost of delivering solar power, initial commercial-scale (>30 MW_e) power towers will likely be hybridized with conventional fossil-fired plants. Many hybridization options are possible with natural gas combined-cycle and coal-fired or oil-fired Rankine plants. One opportunity for hybrid integration with a combined cycle is depicted in Figure 4.

In a hybrid plant, the solar energy can be used to reduce fossil fuel usage and/or boost the power output to the steam turbine. Typical daily power output from the hypothetical “power boost” hybrid power plant is depicted in Figure 5. From the figure it can be seen that in a power boost hybrid plant we have, in effect, “piggybacked” a solar-only plant on top of a base-loaded fossil-fueled plant.

In the power boost hybrid plant, additional electricity is produced by over sizing the steam turbine, contained within a coal-fired Rankine plant or the bottoming portion of a combined-cycle plant (Figure 4), so that it can operate on both full fossil and solar energy when solar is available. Studies of this concept have typically oversized the steam turbine from 25% to 50% beyond what the turbine can produce in the fossil-only mode. Oversizing beyond this range is not recommended because the thermal-to-electric conversion efficiency will degrade at the part loads associated with operating in the fuel-only mode.

SOLAR POWER TOWER

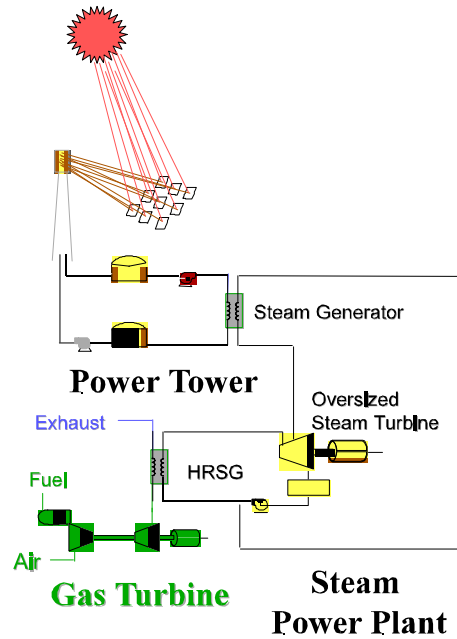

Figure 4. Power tower hybridized with combined cycle plant [4]. Power is produced in the gas turbine (fossil only) and from the steam turbine (fossil and solar). Steam from the solar steam generator is blended with fossil steam from the heat recovery steam generator (HRSG) before entering a steam turbine.

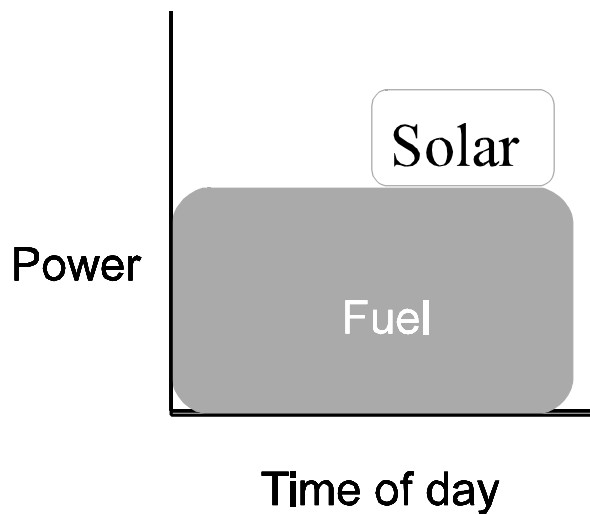

Figure 5. A hypothetical power profile from a hybrid plant. In this case, thermal storage is used to dispatch the solar electricity late in the day to meet an evening peak that lasts well into the night (a pattern that is common in the U.S. Southwest and in many developing nations).

SOLAR POWER TOWER

When hybridizing a solar power tower with a base-load fossil-fired plant, solar contributes about 25% of the peak power output from the plant and between 10 and 25% of the annual electricity. (The higher annual solar fraction can be achieved with 13 hours of thermal storage and the lower solar fraction with just a few hours of storage.) Designing plants with a relatively modest solar fraction reduces financial risk because the majority of the electricity is derived from proven fossil technology and steady payment for power sales is assured.

System Benefits -Energy Storage

The availability of an inexpensive and efficient energy storage system may give power towers a competitive advantage. Table 2 provides a comparison of the predicted cost, performance, and lifetime of solar-energy storage technologies for hypothetical 200 MW plants [5,6].

Table 2. Comparison of solar-energy storage systems.

	Installed cost of energy storage for a 200 MW plant (\$/kWhr.)	Lifetime of storage system (years)	Round-trip storage efficiency (%)	Maximum operating temperature (°C/°F)
Molten-Salt Power Tower	30	30	99	567/1,053
Synthetic-Oil Parabolic Trough	200	30	95	390/734
Battery Storage Grid Connected	500 to 800	5 to 10	76	N/A

Thermal-energy storage in the power tower allows electricity to be dispatched to the grid when demand for power is the highest, thus increasing the monetary value of the electricity. Much like hydro plants, power towers with salt storage are considered to be a dispatchable rather than an intermittent renewable energy power plant. For example, Southern California Edison company gives a power plant a capacity payment if it is able to meet their dispatchability requirement: an 80% capacity factor from noon to 6 PM, Monday through Friday, from June through September. Detailed studies [7] have indicated that a solar-only plant with 4 hours of thermal storage can meet this dispatchability requirement and thus qualify for a full capacity payment. While the future deregulated market place may recognize this value differently, energy delivered during peak periods will certainly be more valuable.

Besides making the power dispatchable, thermal storage also gives the power-plant designer freedom to develop power plants with a wide range of capacity factors to meet the needs of the utility grid. By varying the size of the solar field, solar receiver, and size of the thermal storage, plants can be designed with annual capacity factors ranging between 20 and 65% (see Figure 6).

Economic studies have shown that levelized energy costs are reduced by adding more storage up to a limit of about 13 hours (~65% capacity factor) [8]. While it is true that storage increases the cost of the plant, it is also true that plants with higher capacity factors have better economic utilization of the turbine, and other balance of plant equipment. Since salt storage is inexpensive, reductions in LEC due to increased utilization of the turbine more than compensates for the increased cost due to the addition of storage.

SOLAR POWER TOWER

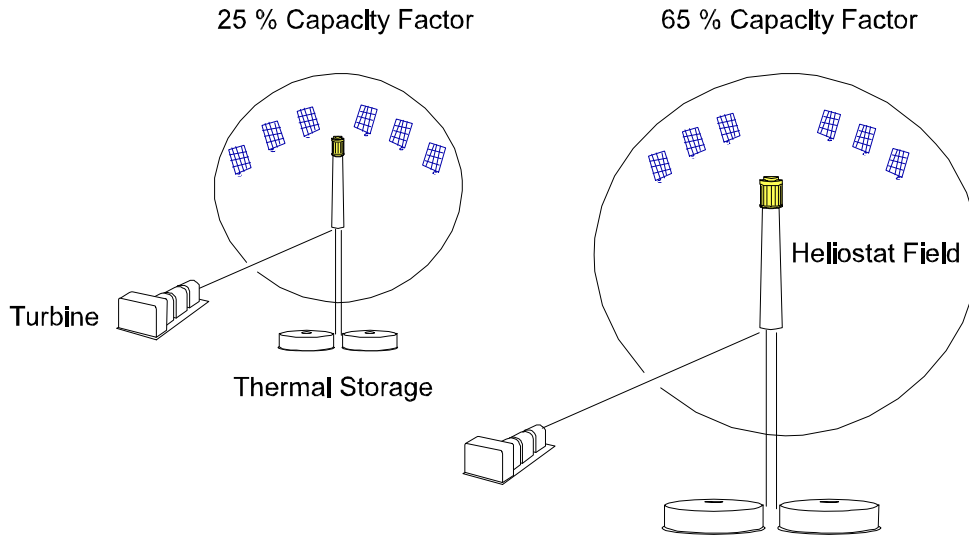

Figure 6. In a solar power tower, plant design can be altered to achieve different capacity factors. To increase capacity factor for a given turbine size, the designer would (1) increase the number of heliostats, (2) enlarge the thermal storage tanks, (3) raise the tower, and (4) increase the receiver dimensions.

Environmental Impacts

No hazardous gaseous or liquid emissions are released during operation of the solar power tower plant. If a salt spill occurs, the salt will freeze before significant contamination of the soil occurs. Salt is picked up with a shovel and can be recycled if necessary. If the power tower is hybridized with a conventional fossil plant, emissions will be released from the non-solar portion of the plant.

3.0 Technology Assumptions and Issues

Assuming success at Solar Two, power tower technology will be on the verge of technology readiness for commercial applications. However, progress related to scale-up and R&D for specific subsystems is still needed to reduce costs and to increase reliability to the point where the technology becomes an attractive financial investment. Promising work is ongoing in the following areas:

First Commercial System

Ideally, to be economically competitive with conventional fossil technology, a power tower should be at least 10 times larger than Solar Two [4]. It may be possible to construct this plant directly following Solar Two, but the risk perceived by the technical and financial communities may require that a plant of intermediate size (30-50 MW) be constructed first. The World Bank will consider requests for funding power tower projects following a successful two-year operation of Solar Two. However, countries interested in the technology have indicated they may need to see a utility-scale plant operating in the U.S. before they will include power towers in their energy portfolio. Since the electricity cost of a stand-alone 30 MW solar-only plant will be significantly higher than the fossil competition, innovative

SOLAR POWER TOWER

financing options or subsidies need to be developed to support this mid-size project. Fossil hybridization designs are also being explored as another possible way of aiding market entry (see hybrid discussion in Section 2). The benefits of the reduced size plant include reduced scale-up risk and reduced capital investment.

Heliostats

Relatively few heliostats have been manufactured to date, and their cost is high ($> \$250/\text{m}^2$). As the demand for solar power increases, heliostat mass production methods will be developed that will significantly reduce their cost (actual evidence of this has been seen in the parabolic trough industry). Research is currently being conducted under the Solar Manufacturing Technology (SolMaT) Initiative to develop low-cost manufacturing techniques for early commercial low volume builds. Prices are a strong function of annual production rate, as shown in Figure 7. They were estimated by U.S. heliostat manufacturers for rates $\leq 2,500/\text{yr}$ [9-11]. The price for high annual production (50,000/yr) is a rough estimate. It was obtained by assuming that the price of the entire heliostat scaled with the price of the drive system. Prices for heliostat drives at production levels from 1 to 50,000 units per year were provided by a U.S. drive manufacturer [12,13]. (50,000 units corresponds to 1 GW of additional capacity per year.)

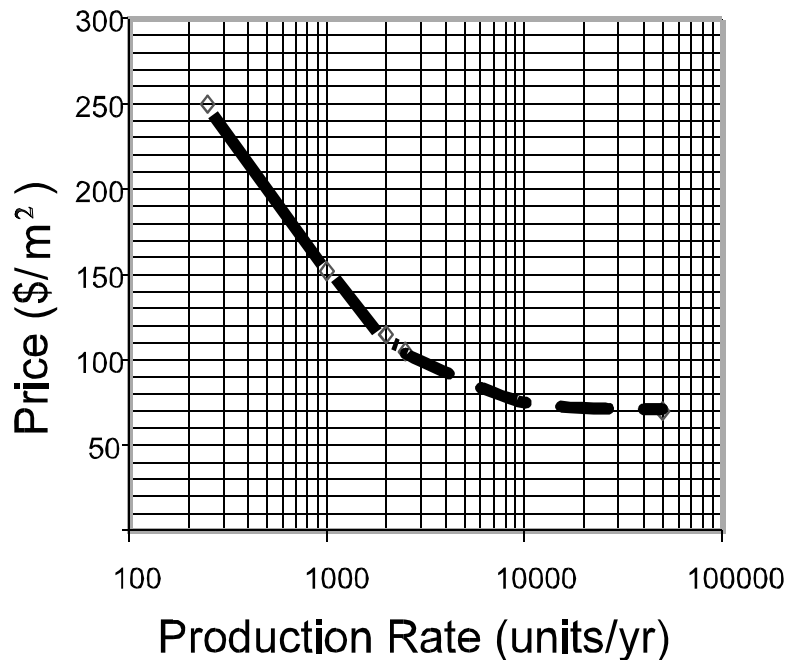

Figure 7. Heliostat price as a function of annual production volume. These prices apply to a heliostat with a surface area of 150 m^2 and similar in design to those tested at Sandia National Laboratories.

Since the heliostat field represents the largest single capital investment in a power tower plant, advancements in technology are needed to improve the ability to manufacture, reduce costs, and increase the service life of heliostats. In particular, a lower cost azimuth drive system is needed (i.e., to rotate the heliostat around an axis that is perpendicular to the ground).

SOLAR POWER TOWER

Receiver

Smaller, simpler receivers are needed to improve efficiency and reduce maintenance. Advanced receiver development currently underway, under the SolMaT Initiative, includes consideration of new steel alloys for the receiver tubes and ease of manufacture for the entire receiver subsystem. Panels of these new receiver designs are being tested at Solar Two.

Molten Salt

Molten nitrate salt, though an excellent thermal storage medium, can be a troublesome fluid to deal with because of its relatively high freezing point (220°C/428°F). To keep the salt molten, a fairly complex heat trace system must be employed. (Heat tracing is composed of electric wires attached to the outside surface of pipes. Pipes are kept warm by way of resistance heating.) Problems were experienced during the startup of Solar Two due to the improper installation of the heat trace. Though this problem has been addressed and corrected, research is needed to reduce the reliance on heat tracing in the plant. This could be accomplished by one or more of the following options: (1) develop a salt “anti-freeze” to lower the freezing point, (2) identify and/or develop components that can be “cold started” without preapplication of the heat trace, or (3) develop thermal management practices that are less reliant on heat trace. Within the Solar Two project, the third option will be explored. If it is unsuccessful, the other two options should be pursued. Also, valves can be troublesome in molten-salt service. Special packings must be used, oftentimes with extended bonnets, and leaks are not uncommon. Furthermore, freezing in the valve or packing can prevent it from operating correctly. While today’s valve technology is adequate for molten-salt power towers, design improvements and standardization would reduce risk and ultimately reduce O&M costs.

Steam Generator

The steam generator design selected for the Solar Two project is completely different than the prototype tested at Sandia Laboratories during the technology development activity of the 1980’s. The recirculating-drum-type system tested at Sandia performed well. However, at Solar Two, a kettle-boiler design was selected in an attempt to reduce cost. Significant problems have been encountered with this new system during the startup phase at Solar Two, requiring a redesign in many areas. Depending on the success of implementing the design changes, it may be appropriate to re-evaluate the optimum steam generator design before proceeding to the first commercial plant.

4.0 Performance and Cost

Table 3 summarizes the performance and cost indicators for the solar power tower system being characterized in this report.

4.1 Evolution Overview

1997 Technology: The 1997 baseline technology is the Solar Two project with a 43 MW_e molten nitrate salt central receiver with three hours of thermal storage and 81,000 m² of heliostats. The solar input is converted in the existing 10 MW net Rankine steam cycle power plant. The plant is described in detail in Section 1.0 and is expected to have a 20% annual capacity factor following its start-up period.

Table 3. Performance and cost indicators.

INDICATOR NAME	UNITS	Solar Two Prototype 1997		Small Hybrid Booster 2000		Large Hybrid Booster 2005		Solar Only 2010		Advanced Solar Only 2020		Advanced Solar Only 2030	
			+/-%		+/-%		+/-%		+/-%		+/-%		+/-%
Plant Size	MW	10		30		100		200		200		200	
Receiver Thermal Rating	MW _t	43		145		470		1,400		1,400		1,400	
Heliostat Size	m ²	40		95		150		150		150		150	
Solar Field Area	m ²	81,000		275,000		883,000		2,477,000		2,477,000		2,477,000	
Thermal Storage	Hours	3		7		6		13		13		13	
	MWh _t	114		550		1,600		6,760		6,760		6,760	
Performance													
Capacity Factor	%	20		43		44		65		77		77	
Solar Fraction		1.00		0.22		0.22		1.00		1.00		1.00	
Direct Normal Insolation	kWh/m ² /yr	2,700		2,700		2,700		2,700		2,700		2,700	
Annual Solar to Elec. Eff.	%	8.5	+5/-20*	15.0	+5/-20	16.2	+5/-20	17.0	+5/-20	20.0	+5/-20	20.0	+5/-20
Annual Energy Production	GWh/yr	17.5		113.0		385.4		1,138.8		1,349.0		1,349.0	
Capital Cost													
Structures & Improvements	\$/kW _{nameplate}	†		116	15	60	15	50	15	50	15	50	15
Heliostat System		†		1,666	25	870	25	930	25	865	25	865	25
Tower/Receiver System				600	25	260	25	250	25	250	25	250	25
Thermal Storage System				370	15	240	15	300	15	300	15	300	15
Steam Gen System				276	15	177	15	85	15	85	15	85	15
EPGS/Balance of Plant				417	15	270	15	400	15	400	15	400	15
Master Control System				33	15	10	15	15	15	15	15	15	15
Directs SubTotal (A)				3,429		1,820		2,030		1,965		1,965	
Indirect Engineering/Other	A * 0.1			343		182		203		197		197	
SubTotal (B)				3,772		2,002		2,233		2,162		2,162	
Project/Process Contingency	B * 0.15			566		300		335		325		325	
Total Plant Cost [‡]				4,338		2,302		2,568		2,487		2,487	
Land (@ \$4,942/hectare)				27		27		37		37		37	
Total Capital Requirements	\$/kW _{nameplate} \$/kW _{peak} [#] \$/m ²			4,365 2,425 476		2,329 1,294 264		2,605 965 210		2,523 934 204		2,523 934 204	
Operation and Maintenance Cost													
Fixed Labor & Materials	\$/kW-yr												
Total O&M Costs		300		67	25	23	25	30	25	25	25	25	25

Notes:

1. The columns for "+/-%" refer to the uncertainty associated with a given estimate.

2. The construction period is assumed to be 2 years.

* Design specification for Solar Two. This efficiency is predicted for a mature operating year.

† Cost of these items at Solar Two are not characteristic of a commercial plant and have, therefore, not been listed.

‡ Total plant cost for Solar Two are the actuals incurred to convert the plant from Solar One to Solar Two. The indirect factors listed do not apply to Solar Two.

To convert to peak values, the effect of thermal storage must be removed. A first-order estimate can be obtained by dividing installed costs by the solar multiple (i.e., $SM = \{\text{peak collected solar thermal power}\} \div \{\text{power block thermal power}\}$). For example, as discussed in the text, in 2010 the peak receiver absorbed power is 1400 MW_e. If this is attached to a 220 MW_e turbine (gross) with a gross efficiency of 42%, thermal demand of the turbine is 520 MW_t. Thus, SM is 2.7 (i.e., 1400/520) and peak installed cost is $2605/2.7 = \$965/\text{kW}_{\text{peak}}$. Solar multiples for years 1997, 2000, and 2005 are 1.2, 1.8, and 1.8, respectively.

SOLAR POWER TOWER

2000 Technology: The first commercial scale power tower project following the Solar Two project is assumed to be a 145 MW_t molten nitrate salt central receiver with seven hours of thermal storage and 275,000 m² of heliostats. The solar plant may be integrated with either a 30 MW_e solar-only Rankine cycle plant or with a combined cycle hybrid system like the power booster system described in Section 2.0. A hybrid plant with a 30 MW_e solar-power-boost, and a 43% annual capacity factor from solar input, is assumed in the case study presented here.

2005 Technology: The system is scaled-up to the original Utility Study [14] size: a 470 MW_t receiver and 883,000 m² heliostat field. Again, the solar plant could be integrated into a 100 MW_e solar-only Rankine power plant or a hybrid combined cycle power-boost system. A hybrid plant with a 100 MW_e solar-power-boost, and a 44% annual capacity factor from solar input, is assumed in the case study presented here.

2010 Technology: In 2010, solar-only nitrate-salt power tower plants are assumed to be competitive. The receiver is scaled up to 1,400 MW_t with thirteen hours of thermal storage and 2,477,000 m² of heliostats. The solar plant is attached to a 200 MW Rankine cycle steam turbine and would achieve an annual capacity factor of about 65%.

2020 Technology: The 2020 technology continues to be a 200 MW Rankine solar-only nitrate-salt power plant. Technology development, manufacturing advances, and increased production volumes are assumed to reduce solar plant cost to mature cost targets. Minor technology advances are assumed to continue to fine-tune overall plant performance.

4.2 Performance and Cost Discussion

All annual energy estimates presented in Table 3 are based on simulations with the SOLERGY computer code [1]. The inputs to the SOLERGY computer code (mirror reflectance, receiver efficiency, startup times, parasitic power, plant availability, etc.) are based on measured data taken from the 10 MW_e Solar One and the small (~1 MW_e) molten-salt receiver system test conducted in the late 1980's [15,16]. The SOLERGY code itself has been validated with a full year of operation at Solar One [17]. However, no overall annual energy data is available from an operating molten-salt power tower. Collection of this data is one of the main goals of the Solar Two demonstration project.

The costs presented in Table 3 for Solar Two are the actuals incurred for the project as reported by Southern California Edison. Capital and operation and maintenance (O&M) cost estimates for 2000 and beyond are consistent with estimates contained in the U.S. Utility Study [14] and the International Energy Agency studies [16]. These studies have been used as a basis to estimate costs for hybrid options and plants with different capacity factors [4]. In addition, O&M costs for power-tower plants with sizes ≤ 100 MW_e have been compared with actuals incurred at the operating 10 to 80 MW_e solar-trough plants in California with similar sizes to insure consistency. Because of the many similarities between trough and tower technology, a first-order assumption that O&M costs at trough and tower plants are similar has been made.

1997 Technology: During 1997, the plant was completing its startup phase. Solar Two is a sub-commercial-scale plant that is designed to demonstrate the essential elements of the technology. To save capital costs, the plant was sized to have a 20% capacity factor and three hours of thermal storage.

SOLAR POWER TOWER

The solar-to-electric annual efficiency at Solar Two will be significantly lower than initial commercial-scale plants (8.5% vs. 15% in Table 3) because:

- Unlike the commercial plant, Solar Two does not use a reheat turbine cycle. Consequently, gross Rankine-cycle efficiency will be revised from 42% to 33%;
- Some of the Rankine-cycle equipment is old and other sections of the plant do not employ the equipment redundancy that is expected in the commercial plant. Plant availability is thus expected to be lowered from 91% to 88%;
- The Solar Two heliostat field is not state-of-the-art. The heliostats being used employ an old control strategy and the mirrors have experienced degradation due to corrosion. Also, the reflectance of these older mirrors is below today's standard (89% vs. 94%). Reflectance, corrosion, and controls are not problems with current heliostat technology. In addition, the 108 new heliostats added to the field, though inexpensive, are too large for the receiver that is installed. Consequently, the reflected beams from these heliostats are too large and a portion of the beams do not intercept the receiver target. Combining all these effects, a field performance degradation factor of about 0.9 relative to the commercial plant is expected; and
- Since Solar Two is only 10 MW with a 20% capacity factor, parasitic electricity use will be a much greater fraction of the total gross generation than for a commercial plant with a much higher capacity factor (e.g. parasitics consumed when the plant is offline will be a much greater fraction of the total when the plant has a 20% rather than a 60% capacity factor.) Parasitic energy use at Solar Two is expected to be about 25% of the total gross generation; for a commercial plant, parasitics are predicted to be about 10%.

Combining the factors discussed above, the simple equation below shows how the 15% annual efficiency for the commercial plant is equivalent to about 8.5% at Solar Two.

$$8.5\% = 15\% * (0.33/0.42) * (0.88/0.91) * (0.9) * (0.75/0.9)$$

The 8.5% efficiency is expected to be achieved at Solar Two during its last year of operation after startup problems with the new technology have been solved.

2000 Technology: Following successful operation of Solar Two, the first commercial scale power tower is assumed to be built in the Southwestern U.S. or within a developing nation. At the present time, the Solar Two business consortium is comfortable with scaling up the Solar Two receiver to 145 MW_t (3.3 times larger than Solar Two [18]). This larger receiver will be combined with a state-of-the-art glass heliostat field (≥ 95 m² each) [19], a next-generation molten-salt steam generator design (based on lessons learned at Solar Two), a high-efficiency steam turbine cycle, and will employ modern balance of plant equipment that will improve plant availability. As pointed out in the previous paragraph, these improvements are expected to increase annual efficiency from 8.5 to 15%.

To reduce the financial risk associated with the deployment of this first commercial-scale plant and to lower the cost of delivering solar power, the plant will likely be hybridized with a base-loaded fossil-fired plant. If the solar plant is interfaced with a combined cycle plant, the system layout could be similar to that depicted in Figure 4. Hybridization significantly reduces the cost of producing solar power relative to a solar-only design for the following reasons:

SOLAR POWER TOWER

- Capital costs for the solar turbine are reduced because only an increment to the base-load fossil turbine must be purchased;
- O&M costs are reduced because only an increment beyond the base-load O&M staff and materials must be used to maintain the solar-specific part of the plant; and,
- The solar plant produces more electricity because the turbine is hot all the time and daily startup losses incurred in a solar-only plant are avoided.

A 145 MW_t receiver that is interfaced with a 30 MW_e turbine-generator increment to a 105 MW_e base-loaded fossil plant would yield approximately a 43% annual solar capacity factor, based on SOLERGY simulations. This plant would have about 7 hours of storage (550 MWh_t, or 5 times larger than Solar Two) and would be capable of dispatching power to meet a late afternoon or early evening peak power demand that is typically seen on utility-power grids (see Figure 5).

2005 Technology: The receiver in this plant is scaled-up another factor of 3.3 to 470 MW_t. The receiver materials will likely be improved relative to the 316 stainless steel tubes currently used at Solar Two. Stainless is limited to a peak incident flux of about 800 suns. SunLab and Rocketdyne are currently testing advanced receiver materials that appear capable of withstanding greater than 1100 suns. This higher-concentration receiver will be able to absorb a given amount of solar energy with a smaller surface area. Reducing surface area improves efficiency because thermal losses are lowered. In addition, advanced manufacturing techniques currently being developed in a Sandia/Boeing research project (e.g. pulled tube-to-header connections) will be employed to reduce the cost of the receiver and improve reliability.

Large-area heliostats (150 m²), similar to those successfully tested at Sandia National Laboratories [19], are expected to be used. The improved economy of scale will significantly reduce the cost of the heliostats on a \$/m² basis. In addition, increases in annual production are expected to lower heliostat costs.

A hybrid plant is again proposed to help mitigate the scale-up risk and to reduce the cost of producing solar power. System configuration could be similar to Figure 4.

A 470 MW_t receiver that is interfaced with a 100 MW_e turbine-generator increment to a 350 MW_e base-loaded fossil plant would yield approximately a 44% annual solar capacity factor, based on SOLERGY simulations. This plant would have about 6 hours of storage (1,600 MWh_t) and would be capable of dispatching power to meet a late afternoon or early evening peak power demand.

2010 Technology: In 2010, the first commercial-scale solar-only plants are assumed to be built. Scoping calculations at Sandia National Laboratories suggest that it is feasible to scale-up the receiver another factor of three to a rating of about 1,400 MW_t. If this receiver is attached to a 200 MW steam generation/turbine system, 13 hours of thermal storage (6,760 MWh_t) would be necessary to avoid overflow of the storage and a significant discard of solar energy. The annual capacity factor of this plant would be approximately 65%, and it would run at full turbine output nearly 24 hours/day during the summer months when the daylight hours are longer. During the winter, when days are shorter, the plant would shut down during several hours per night. Alternatively, the turbine could run at part load to maintain the turbine on line. This plant is approaching base-load operation. The same 1,400 MW_t receiver/6,760 MWh_t storage system could also be attached to a 400 MW steam turbine. In this case, the annual capacity factor would be about 33% and the electricity would be dispatched to meet the peaking demands of the grid. However, in this technical characterization, the power tower plant is assumed to be attached to a 200 MW_e turbine.

SOLAR POWER TOWER

2020 Technology: Power plant size is assumed to remain at 200 MW_e. Power towers built between the years 2010 and 2020 should have a receiver that has a significantly higher efficiency than is currently possible with today's technology. Receivers within current power towers are coated with a highly absorptive black paint. However, the emissivity of the paint is also high which leads to a relatively large radiation loss. Future power tower receivers will be coated with a selective surface with a very low emissivity that will significantly reduce radiation losses. Selective surfaces similar to what is needed are currently used in solar parabolic trough receivers. Additional research is needed to produce a surface that won't degrade at the higher operating temperature of the tower (i.e., 650°C/1,202°F vs. 400°C/752°F). Given this improvement, scoping calculations at Sandia indicate that annual receiver efficiency should be improved to about 90%.

By 2020, further improvements in heliostat manufacturing techniques, along with significant increases in annual production, are expected to lower heliostat costs to their final mature value (~\$70/m², see Figure 7). The reflectance of the mirrors is also expected to be improved from the current value of 94% to a value of at least 97%. Advanced reflective materials are currently being investigated in the laboratory.

As the technology reaches maturity, plant parasitics will be fully optimized and plant availability will also improve. Combining all the effects described above, annual plant efficiency is expected to be raised to 20% and annual capacity factor should be raised above 75%.

2030 Technology: No significant improvements in molten nitrate salt power tower technology are assumed beyond 2020. In order for significant improvements to continue, a radical change in power tower technology must take place. Ideas under consideration are an advanced receiver that is capable of efficiently heating air to gas-turbine temperatures (>1,400°C/2,552°F) and pressures (>1,500 kPa) in conjunction with a high-temperature phase-change thermal storage system. If this can be achieved, large solar-only plants with a combined-cycle power block efficiency of 60% or more might be achieved. In addition, as receiver temperatures exceed 1000°C (1,832°F), thermal-chemical approaches to hydrogen generation could be exploited using solar power towers. Since these ideas are in such an early stage, no defendable cost and performance projections can be made at this time.

5.0 Land, Water, and Critical Materials Requirements

The land and water use values provided in Table 4 apply to the solar portion of the power plant. Land use in 1997 is taken from Solar Two design documents. Land use for years 2000 and beyond is based on systems studies [14,16]. The proper way to express land use for systems with storage is ha/MWhr/yr. Expressing land use in units of ha/MW is meaningless to a solar plant with energy storage because the effect of plant capacity factor is lost.

Water use measured at the SEGS VI and VII [20] trough plants form the basis of these estimates. Wet cooling towers are assumed. Water usage at Solar Two should be somewhat higher than at SEGS VI and VII due to a lower power block efficiency at Solar Two (33% gross). However, starting in the year 2000, water usage in a commercial power tower plant, with a high efficiency power block (42% gross), should be about 20% less than SEGS VI and VII. If adequate water is not available at the power plant site, a dry condenser-cooling system could possibly be used. Dry cooling can reduce water needs by as much as 90%. However, if dry cooling is employed, cost and performance penalties are expected to raise levelized-energy costs by at least 10%.

SOLAR POWER TOWER

Table 4. Resource requirements.

Indicator Name	Units	Base Year 1997	2000	2005	2010	2020	2030
Land	ha/MWh/yr	2.7×10^{-3}	1.5×10^{-3}	1.4×10^{-3}	1.3×10^{-3}	1.1×10^{-3}	1.1×10^{-3}
Water	m ³ /MWh	3.2	2.4	2.4	2.4	2.4	2.4

6.0 References

1. Stoddard, M.C., et. al., SOLERGY - A Computer Code for Calculating the Annual Energy from Central Receiver Power Plants, Sandia National Laboratories, Livermore, CA: May 1987. Report SAND86-8060.
2. Meinecke, W., and M. Bohn, Solar Energy Concentrating Systems: Applications and Technologies, edited by M. Becker, and B. Gupta, Muller Verlag, Heidelberg, Germany, 1995.
3. Anderson, D. And K. Ahmed, The Case for the Solar Energy Investments, World Bank Technical Paper Number 279 - Energy Series, World Bank, Washington D.C.: February 1995. ISBN 0-8213-3196-5
4. Kolb, G.J., "Economic Evaluation of Solar-Only and Hybrid Power Towers Using Molten Salt Technology", Proceedings of the 8th International Symposium on Solar Thermal Concentrating Technologies, Cologne, Germany (October 6-11, 1996). Accepted for publication in the journal Solar Energy.
5. Karl W. Boer, ed., Advances in Solar Energy - An Annual Review of Research and Development, Volume 11, Chapter 1, article by Mancini, T.R., M.R. Prairie, and G.J. Kolb, American Solar Energy Society, Inc., Boulder, CO, 1997. ISBN 0-89553-254-9.
6. Akhil, A.A., S.K. Swaminathan, and R.K. Sen, Cost Analysis of Energy Storage for Electric Utility Applications, Sandia National Laboratories: February 1997. Report SAND97-0443.
7. Chiang, C. J., SUNBURN: A Computer Code for Evaluating the Economic Viability of Hybrid Solar Central Receiver Electric Power Plants, Sandia National Laboratories, Albuquerque, NM: June 1987. Report SAND86-2165.
8. Falcone, P.K., A Handbook for Solar Central Receiver Design, Sandia National Laboratories, Livermore, CA: December, 1986. Report SAND86-8009.
9. "Heliostat Cost Study for SOLMAT Program," Science Applications International Corporation, for National Renewable Energy Laboratory, Golden, CO: 1996.
10. "Heliostat Cost Study for SOLMAT Program," Solar Kinetics and Advanced Thermal Systems, for National Renewable Energy Laboratory, Golden, CO: 1996.
11. Gorman, D., Heliostat Costs at Reduced Production Volumes - Report to Sandia National Laboratories, Advanced Thermal Systems: 1993.
12. Development of a Low-Cost Drive Tracking Mechanism for Solar Heliostats or PV Arrays - Final Report, Peerless Winsmith, Inc, for Sandia National Laboratories: February 1989. Report 90-5753.

SOLAR POWER TOWER

13. Sutton, W.F., Prices of Drives at Different Production Volumes - Report to Sandia National Labs, Peerless-Winsmith, Inc.: April 4, 1989.
14. Solar Central Receiver Technology Advancement for Electric Utility Application, Phase 1 Topical Report, Pacific Gas & Electric Company, San Francisco, CA: September 1988. Report 007.2-88.2.
15. Smith, D.C., and J.M. Chavez, A Final Report on the Phase 1 Testing of a Molten-Salt Cavity Receiver, Sandia National Laboratories, Albuquerque, NM: 1988. Report SAND87-2290.
16. Kolb, G., J. Chavez, and W. Meinecke, Second Generation Central Receiver Technologies: A Status Report, M. Becker, and P. Klimas, eds., Verlag C.F. Muller Karlsruhe, DLR, and Sandia National Laboratories: 1993. Report ISBN 3-7880-7482-5.
17. Alpert, D.J., and G.J. Kolb, Performance of the Solar One Power Plant as Simulated by the SOLERGY Computer Code, Sandia National Laboratories, Albuquerque, NM: 1988. Report SAND88-0321.
18. Central Receiver Commercialization Plan, Bechtel National Inc., for the California Energy Commission: June 1995. Report 01-0444-35-3027-2777.
19. Strachan, J.W., and R.M. Houser, Testing and Evaluation of Large-Area Heliostats for Solar Thermal Applications, Sandia National Laboratories, Albuquerque, NM: February 1993. Report SAND92-1381.
20. O&M Cost Reduction in Solar Thermal Electric Plants - 2nd Interim Report on Project Status, KJC Operating Company, for Sandia National Laboratories: July 1, 1996.