

Table of Contents

Section 7	
Inspection and Evaluation of Common Concrete Superstructures		
7.9	Prestressed I-Beams and Bulb-Tees.....	7.9.1
7.9.1	Introduction.....	7.9.1
7.9.2	Design Characteristics.....	7.9.1
	General.....	7.9.1
	Materials - Strength and Durability	7.9.2
	Continuity	7.9.3
	Composite Action	7.9.4
	Primary Members and Secondary Members.....	7.9.5
	Steel Reinforcement.....	7.9.5
	Primary Reinforcement.....	7.9.5
	High Strength Steel	7.9.5
	Mild Steel	7.9.5
	Secondary Reinforcement.....	7.9.6
	Composite Strands	7.9.6
7.9.3	Overview of Common Defects	7.9.6
7.9.4	Inspection Procedures and Locations	7.9.7
	Procedures	7.9.7
	Visual.....	7.9.7
	Physical.....	7.9.7
	Advanced Inspection Techniques	7.9.7
	Locations	7.9.8
	Bearing Areas.....	7.9.8
	Shear Zones.....	7.9.9
	Tension Zones.....	7.9.9
	Secondary Members.....	7.9.10
	Areas Exposed to Drainage.....	7.9.11
	Areas Exposed to Traffic	7.9.12

SECTION 7: Inspection and Evaluation of Common Concrete Superstructures
TOPIC 7.9: Prestressed I-Beams and Bulb Tees

	Areas Previously Repaired.....	7.9.13
	General.....	7.9.13
7.9.5	Evaluation	7.9.14
	NBI Rating Guidelines	7.9.14
	Element Level Condition State Assessment.....	7.9.14

Topic 7.9 Prestressed I-Beams and Bulb-Tees

7.9.1

Introduction

Prestressed I-beams and bulb-tees have been used since the 1950's. They have proven to be effective because of their material saving shapes. The I or T shape allows a designer to have enough space to place the proper amount of reinforcement while reducing the amount of concrete needed (see Figure 7.9.1).



Figure 7.9.1 Prestressed I-beam Superstructure

7.9.2

Design Characteristics

Prestressed I-beams and bulb-tees make economical use of material since most of the concrete mass is located away from the neutral axis of the beam.

General

Prestressed I-beams are shaped to provide minimum dead load with ample space for tendons. The most common prestressed concrete I-beam shapes are the AASHTO shapes used by most state highway agencies (see Figure 7.9.2). However, some highway agencies have developed variations of the AASHTO shapes to accommodate their particular needs.

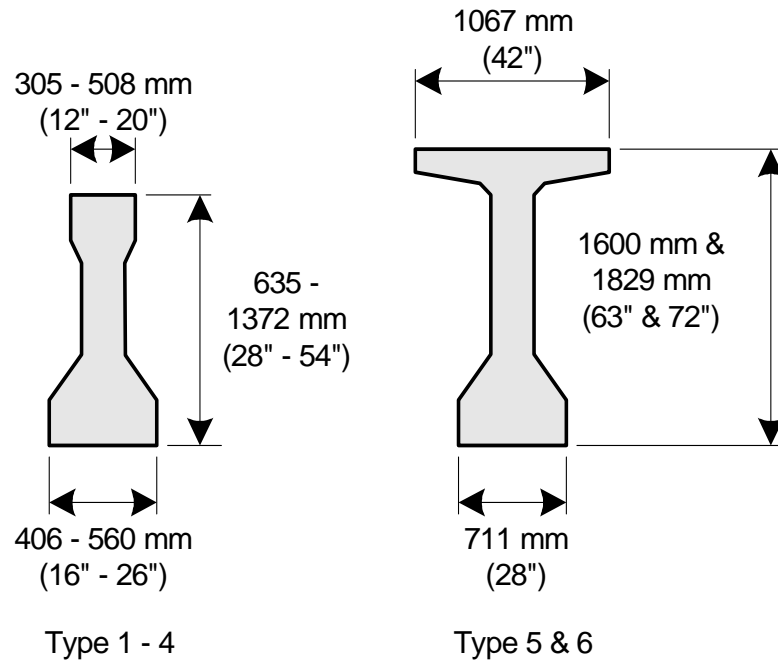

Figure 7.9.2 AASHTO Cross Sections of Prestressed I-beams

Prestressed I-beams are used in spans ranging from 6 to 46 m (20 to 150 feet). They are generally most economical at spans from 18 to 35 m (60 to 115 feet).

Materials – Strength and Durability

Steel tendons with a tensile strength as high as 1860 Mpa (270 ksi) are located in the bottom flange. These tendons are used to induce compression across the entire section of the beam prior to and during application of live load. This results in a crack free beam when subjected to live load (see Topic 2.2.4).

New technology may allow designers to reduce corrosion of prestressing strands. This reduction is made possible by using composite materials in lieu of steel. Carbon or glass fibers are two alternatives to steel prestressing strands that are being researched.

Concrete used is also of higher strength ranging from 34 Mpa (5,000 psi) compressive strength up to 83 Mpa (12,000 psi). In addition, concrete has a higher quality due to better control of fabrication conditions in a casting yard.

Reactive Powder Concrete (RPC) prestressed beams can come in an X shape (see Figure 7.9.3) or other concrete beam shapes. RPC prestressed beams may have an hourglass shape so as to take maximum advantage of RPC properties. Tested prestressed RPC beams are made without any secondary steel reinforcement and can carry the same load as a steel I-beam with virtually the same depth and weight.



Figure 7.9.3 Reactive Powder Concrete (RPC) Prestressed X-beam

Reactive Powder Concrete (RPC) creates a better bond between the cement and aggregate. This bond produces a material with a higher density, shear strength, and ductility than normal strength concrete. Silica fume is one of the ingredients in Reactive Powder Concrete that increases the strength. RPC prestressed beams are effective in situations where steel I-beams may be used, but are not effective where conventional strength prestressed concrete I-beams are strong enough.

Continuity

To increase efficiency in multi-span applications, prestressed I-beams and bulb-tees can be made continuous for live load and/or to eliminate the deck joint. This is done using a continuous composite action deck and anchorage of mild steel reinforcement in a common end diaphragm (see Figures 7.9.4 and 7.9.5). Continuity has also been accomplished using posttensioning ducts cast into pretensioned beams. Tendons pulled through these ducts across several spans then are stressed for continuity. Cast-in-place concrete diaphragms are framed around the beams at the abutments and piers.

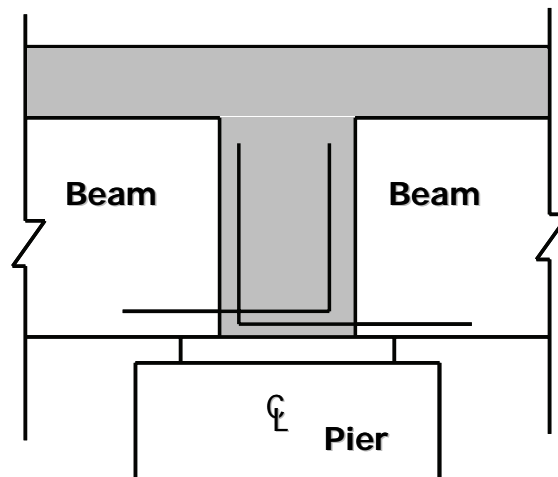

Figure 7.9.4 Continuous Prestressed I-beam Schematic



Figure 7.9.5 Continuous Prestressed I-Beam Bridge

Composite Action

The deck is secured to and can be made composite with the prestressed beam by the use of extended stirrups which are cast into the I-beam (see Figure 7.9.6).



Figure 7.9.6 Cast-In-Place Stirrups

Primary Members and Secondary Members

The primary members are the prestressed beams. The secondary members are the end diaphragms and the intermediate diaphragms. End diaphragms are usually full depth and located at the abutments or piers. Intermediate diaphragms are partial depth and are used within the span for longer spans (see Figure 7.9.7). Diaphragms are cast-in-place concrete or rolled steel sections and are placed at either the end points, mid points, or third points along the span.



Figure 7.9.7 Concrete End Diaphragm

Steel Reinforcement

Primary Reinforcement

Primary reinforcement consists of main tension steel and shear reinforcement or stirrups.

High Strength Steel

Main tension steel consists of pretensioned high strength prestressing strands or tendons placed symmetrically in the bottom flange and lower portion of the web. Strands are 9.5, 11.1, 12.7, or 15.2 mm (3/8, 7/16, 1/2 or 0.6 inch) in diameter and are generally spaced in a 50.8 mm (2 inch) grid. In the larger beams, main tension steel can include posttensioned continuity tendons which are located in ducts cast into the beam web (see Figure 7.9.8).

Mild Steel

Mild steel stirrups are vertical in the beam and located throughout the web at various spacings required by design (see Figure 7.9.8).

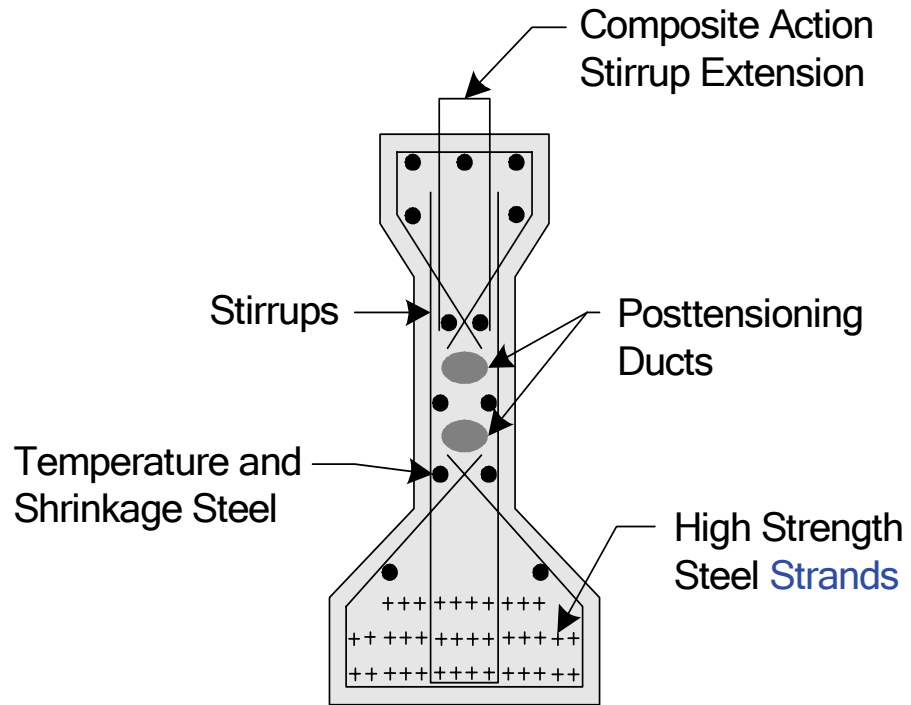

Figure 7.9.8 Prestressed I-beam Reinforcement (Schematic)

Secondary Reinforcement

Secondary reinforcement includes mild steel temperature and shrinkage reinforcement which is longitudinal in the beam.

Composite Strands

Composite strands can be carbon fiber or glass fiber and are fairly new to the bridge prestressing industry. These strands are gaining acceptance due to the low corrosive properties compared to steel strands and will just be mentioned in this manual.

7.9.3

Overview of Common Defects

Common defects that occur on prestressed I-beams and bulb-tees include:

- Cracking (flexure, shear, temperature, shrinkage, mass concrete)
- Scaling
- Delamination
- Spalling
- Chloride contamination
- Efflorescence
- Ettringite formation
- Honeycombs
- Pop-outs
- Wear

- Collision damage
- Abrasion
- Overload damage
- Reinforcing steel corrosion
- Prestressed concrete deterioration
- Stress corrosion of prestressing strands

Refer to Topic 2.2 for a detailed presentation of the properties of concrete, types and causes of concrete deterioration, and the examination of concrete.

7.9.4

Inspection Procedures and Locations

Inspection procedures to determine other causes of concrete deterioration are discussed in detail in Topic 2.2.8.

Procedures

Visual

The inspection of prestressed concrete I-beams and bulb-tees for cracks, spalls, and other defects is primarily a visual activity.

Physical

Sounding by hammer can be used to detect delaminated areas. A delaminated area will have a distinctive hollow “clacking” sound when tapped with a hammer or revealed with a chain drag. A hammer hitting sound concrete will result in a solid “pinging” type sound.

Since prestressed beams are designed to maintain all concrete in compression, cracks are indications of serious problems. For this reason, any crack should be carefully measured with an optical crack gauge or crack comparator card and documented.

Advanced Inspection Techniques

Several advanced techniques are available for concrete inspection. Nondestructive methods, described in Topic 13.2.2, include:

- Acoustic wave sonic/ultrasonic velocity measurements
- Delamination detection machinery
- Electrical methods
- Electromagnetic methods
- Pulse velocity
- Flat jack testing
- Ground-penetrating radar
- Impact-echo testing
- Infrared thermography
- Laser ultrasonic testing
- Magnetic field disturbance

SECTION 7: Inspection and Evaluation of Common Concrete Superstructures
TOPIC 7.9: Prestressed I-Beams and Bulb-Tees

- Neutron probe for detection of chlorides
- Nuclear methods
- Pachometer
- Rebound and penetration methods
- Ultrasonic testing

Other methods, described in Topic 13.2.3, include:

- Core sampling
- Carbonation
- Concrete permeability
- Concrete strength
- Endoscopes and videoscopes
- Moisture content
- Petrographic examination
- Reinforcing steel strength
- Chloride test
- Matrix analysis
- ASR evaluation

Locations

Bearing Areas

Check bearing areas for defects such as delaminations, spalls or vertical cracks (see Figure 7.9.9). Defects may be caused by corrosion of steel due to water leakage or restriction of thermal movement due to a faulty bearing mechanism. Spalling could also be caused by poor quality concrete placement (see Figure 7.9.10).

Check for crushing of flange near the bearing seat.

Check for rust stains which indicate corrosion of steel reinforcement.

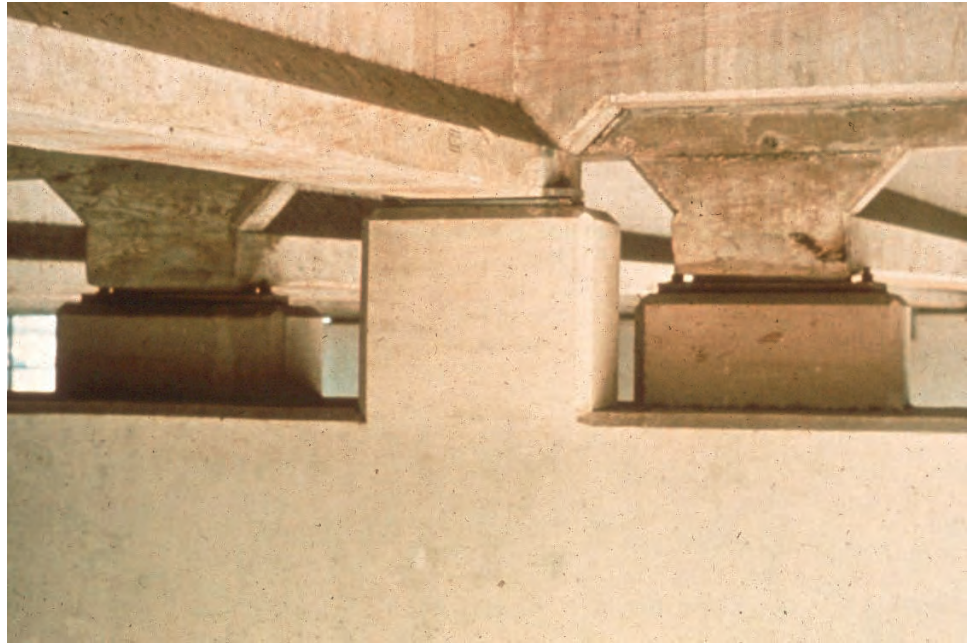

Figure 7.9.9 Bearing Area of a Typical Prestressed I-beam



Figure 7.9.10 Spalling Due to Poor Concrete

Shear Zones

Check beam ends and sections over piers for transverse cracks on the bottom flange and for diagonal shear cracks in webs. These web cracks will project diagonally upward from the support toward midspan.

Tension Zones

Inspect the tension zones of the beams for structural cracks. Cracking indicates a very serious problem resulting from overloading or loss of prestress.

Check for deteriorated concrete that could cause debonding of the tension reinforcement. This would include spalls, delamination, and cracks with efflorescence.

Check bottom flange for longitudinal cracks that may indicate a deficiency of prestressing steel, insufficient cover, inadequate spacing, or possibly an overloading of the concrete due to use of prestressing strands that are too large.

Check bottom flange at midspan for flexure cracks due to positive moment (see Figure 7.9.11). These cracks will be quite small and difficult to detect. An optical crack gauge or crack comparator card should be used to measure any cracks found.

For continuous bridges, check the deck area over the piers for flexure cracks due to negative moment.

Check for rust stains from cracks, indicating corrosion of steel reinforcement or prestressing tendons.

Check for exposed tension reinforcement and document section loss. Measurable section loss will decrease live load capacity. Exposed prestressing tendons are susceptible to stress corrosion and sudden failure.



Figure 7.9.11 Flexure Crack

Secondary Members

Inspect the end diaphragms for spalling or diagonal cracking (see Figure 7.9.12). This is a possible sign of overstress caused by substructure movement.

Investigate the intermediate diaphragms for cracking and spalling concrete. Flexure and shear cracks may indicate excessive differential movement of the I-beams.



Figure 7.9.12 Typical Concrete Diaphragm

Areas Exposed to Drainage

Check around joints, scuppers, inlets or drain holes for leaking water or deterioration of concrete (see Figure 7.9.13).



Figure 7.9.13 Leakage of Water at Joint between Spans

Areas Exposed to Traffic

Check areas damaged by collision. A significant amount of prestressed concrete bridge deterioration and loss of section is caused by traffic damage. Document the number of exposed and severed strands as well as the loss of concrete section. The loss of concrete due to such an accident is not always serious, unless the bond between the concrete and steel reinforcement is affected (see Figure 7.9.14).



Figure 7.9.14 Collision Damage on Prestressed Concrete I-beam

Areas Previously Repaired

Examine thoroughly any repairs that have been previously made. Determine if repaired areas are sound and functioning properly. Effective repairs and patching are usually limited to protection of exposed tendons and reinforcement (see Figure 7.9.15).



Figure 7.9.15 Collision Damage Repair on Prestressed Concrete I-beam. Note Epoxy Injection Ports

General

Using a string line, check for horizontal alignment and camber of the prestressed beams. Signs of downward deflection usually indicate loss of prestress. Signs of excessive upward deflection usually indicate extreme creep and shrinkage.

7.9.5

Evaluation

State and federal rating guideline systems have been developed to aid in the inspection of concrete superstructures. The two major rating guideline systems currently in use are the FHWA's *Recording and Coding Guide for the Structural Inventory and Appraisal of the Nation's Bridges* used for the National Bridge Inventory (NBI) component rating method and the AASHTO element level condition state assessment method.

NBI Rating Guidelines

Using NBI rating guidelines, a 1-digit code on the Federal Structure Inventory and Appraisal (SI&A) sheet indicates the condition of the superstructure. Rating codes range from 9 to 0, where 9 is the best rating possible. See Topic 4.2 (Item 59) for additional details about NBI Rating Guidelines.

The previous inspection data should be considered along with current inspection findings to determine the correct rating.

Element Level Condition State Assessment

In an element level condition state assessment of a prestressed I-beam or bulb-T bridge, the AASHTO CoRe element is:

<u>Element No.</u>	<u>Description</u>
109	Prestressed Concrete Open Girder/beam

The unit quantity for the prestressed double I-beam is meters or feet, and the total length must be distributed among the four available condition states depending on the extent and severity of deterioration. Condition state 1 is the best possible rating. See the *AASHTO Guide for Commonly Recognized (CoRe) Structural Elements* for condition state descriptions.

A Smart Flag is used when a specific condition exists, which is not described in the CoRe element condition state. The severity of the damage is captured by coding the appropriate Smart Flag condition state. The Smart Flag quantities are measured as each, with only one each of any given Smart Flag per bridge.

For damage due to traffic impact, the "Traffic Impact" Smart Flag, Element No. 362, can be used and one of the three condition states assigned.

Table of Contents

Section 7	
Inspection and Evaluation of Common Concrete Superstructures		
7.10 Prestressed Box Beams	7.10.1
7.10.1 Introduction	7.10.1
7.10.2 Design Characteristics	7.10.1
General	7.10.1
Design	7.10.2
Simple/Continuous Spans	7.10.2
Composite/Noncomposite	7.10.2
Construction	7.10.3
Advantages	7.10.3
Dead Load Reduction	7.10.3
Construction Time Savings	7.10.3
Shallow Depth	7.10.4
Applications	7.10.4
Adjacent Box Beams	7.10.4
Monolithic Action	7.10.5
Spread Box Beams	7.10.6
Primary Members and Secondary Members	7.10.6
Steel Reinforcement	7.10.7
Primary Reinforcement	7.10.7
Secondary Reinforcement	7.10.8
Fiber Reinforced Polymer Strands	7.10.8
7.10.3 Overview of Common Defects	7.10.8
7.10.4 Inspection Procedures and Locations	7.10.9
Procedures	7.10.9
Visual	7.10.9
Physical	7.10.9
Advanced Inspection Techniques	7.10.9

SECTION 7: Inspection and Evaluation of Common Concrete Superstructures
TOPIC 7.10: Prestressed Box Beams

	Locations	7.10.10
	Bearing Areas.....	7.10.10
	Shear Zones.....	7.10.12
	Tension Zones.....	7.10.12
	Secondary Members.....	7.10.13
	Areas Exposed to Drainage.....	7.10.14
	Areas Exposed to Traffic	7.10.15
	Areas Previously Repaired.....	7.10.15
	General.....	7.10.15
7.10.5	Evaluation	7.10.16
	NBI Rating Guidelines	7.10.16
	Element Level Condition State Assessment.....	7.10.17

Topic 7.10 Prestressed Box Beams

7.10.1

Introduction

Prestressed box beams are quite popular and have been used since the early 1950's (see Figure 7.10.1). These precast prestressed members provide advantages from a construction and an economical standpoint by increasing strength while decreasing the dead load.



Figure 7.10.1 Typical Box Beam Bridge

7.10.2

Design Characteristics

General

Prestressed box beams are constructed having a rectangular cross section with a single rectangular void inside. Many prestressed box beams constructed in the 1950's have single circular voids. The top and bottom slabs act as the flanges, while the side walls act as webs. The prestressing reinforcement is typically placed in the bottom flange and into both webs (see Figure 7.10.2).

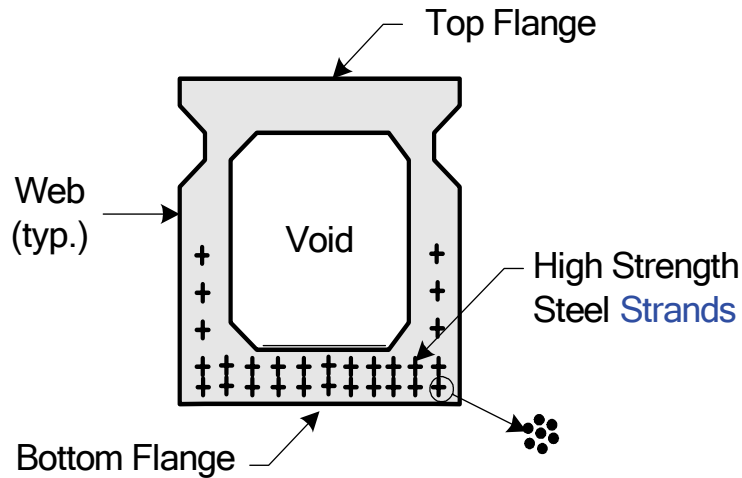

Figure 7.10.2 Box Beam Cross-Section

The typical span length for prestressed concrete box beams ranges from 6 to 27 m (20 to 90 ft) depending on the beam size and spacing.

Prestressed box beams are typically either 915 to 1220 mm (36 or 48 inches) wide. The depth of a box beam is typically 690 to 1070 mm (27 to 42 inches). Web wall thickness are typically 125 mm (5 inches) but can range from 75 to 150 mm (3 to 6 inches).

Design

Simple/Continuous Spans

Prestressed box beams can be simple or continuous spans. In the case of simple spans, the ends of the beams from span to span are not connected together at the support. An expansion joint is placed over the support in the concrete deck and the spans act independently. For continuous spans, the beam-ends from span to span are connected together by means of a cast-in-place concrete end diaphragm over the support. Mild steel reinforcement is placed in this diaphragm area and is spliced with steel reinforcement from the prestressed box beams (see Figure 7.10.3). Additional mild steel reinforcement is placed longitudinally in the deck. Continuous spans provide advantages such as eliminating deck joints, making a continuous surface for live loads, distributing live loads, and lowering positive moment.

Composite/Non-composite

Prestressed box beams can be composite or non-composite. To obtain composite action, some prestressed box beams are constructed with stirrups extending out of the top flange (see Figure 7.10.3). These stirrups are engaged when a cast-in-place concrete deck is placed and hardens. Once the concrete deck hardens, the deck becomes composite with the prestressed box beams. This configuration can be considered composite since the compressive strength of the cast-in-place deck is significantly different than the precast prestressed box beams.

Prestressed box beams can also be non-composite. If the stirrups are not extended into the deck, the prestressed box beams cannot achieve composite action with the deck.

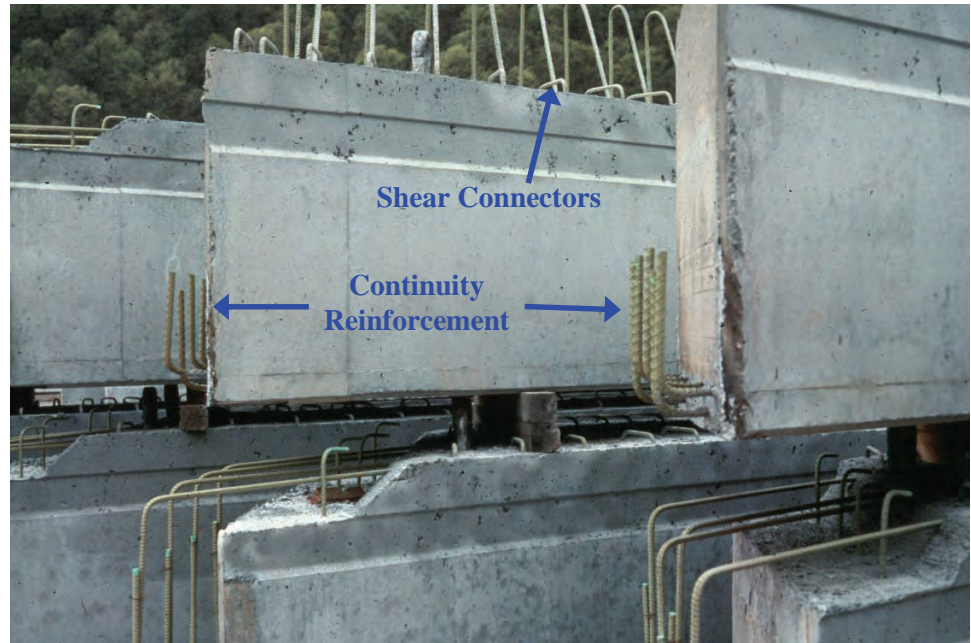

Figure 7.10.3 Box Beams at Fabrication Plant Showing Stirrups Extended as Shear Connectors and Extended Rebar for Continuity

Construction

Box beams are constructed similar to I-beams, with high strength steel strands or tendons placed in the bottom flange and lower web area. The strength of the steel strands can be as high as 1860 MPa (270 ksi).

Concrete compressive strengths of 27 to 41 MPa (4000 to 6000 psi) are typically used in prestressed box beams, but concrete with ultimate strengths over 83 MPa (12,000 psi) is available and becoming popular.

High performance concrete (HPC), which is a new type of concrete being used in bridge members, is designed to meet the specific needs of a specific project. The mix design is based on the environmental conditions, strength requirements, and durability requirements. This type of concrete allows engineers to design smaller, longer, and more durable members with longer life expectancies.

Advantages

Dead Load Reduction

The voided box beam reduces dead load while still providing flanges to resist the design moments and webs to resist the design shears.

Construction Time Savings

Precast members are cast and cured in a quality controlled casting yard. Because box beams are precast, the construction process takes less time. When construction is properly planned, using precast members allows structure to be erected with less traffic disruption than typical cast-in-place concrete construction.

Shallow Depth

Prestressed box beams are designed with a typical maximum depth of 1070 mm (42 inches). This shallow depth makes box beams viable solutions for field conditions where shallow vertical clearances exist.

Applications

There are two applications of prestressed box beams (see Figure 7.10.4):

- Adjacent box beams
- Spread box beams

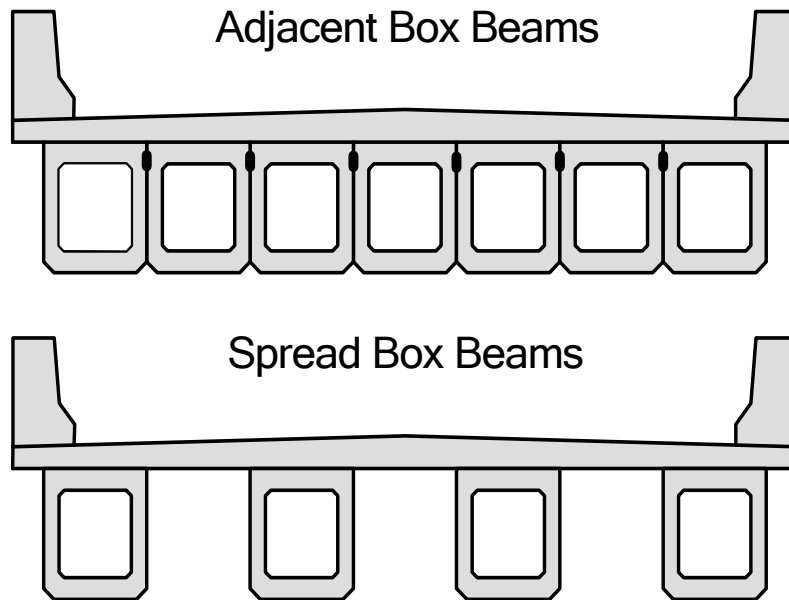

Figure 7.10.4 Applications of Prestressed Box Beams

Adjacent Box Beams

On an adjacent box beam bridge, the adjacent box beams are placed laterally side by side with no space between them. In some early applications, the top flange of each box is exposed and functions as the deck (see Figure 7.10.5). The practical span lengths range from 6 to 40 m (20 to 130 feet), with the most economical spans ranging from 12 to 27 m (40 to 90 feet).



Figure 7.10.5 Adjacent Box Beams: Top Flanges Acting as the Deck

In modern longer span applications, the deck is typically cast-in-place concrete, and composite action with the box beam is achieved after the concrete hardens. For composite decks, stirrups extend above the top of the box to provide the transfer of shear forces. For the majority of shorter spans, nonstructural asphalt overlays are applied. Sometimes a waterproofing membrane is applied prior to the overlay placement.

Monolithic Action

Like precast slab units, adjacent box beams are post tensioned transversely. This is generally done using 1000 MPa (145 ksi) threaded bars and lock nuts, or 1860 MPa (270 ksi) strands with locking wedges. Transverse post tensioning combined with grouted shear keys provides for monolithic action (see Figure 7.10.6).

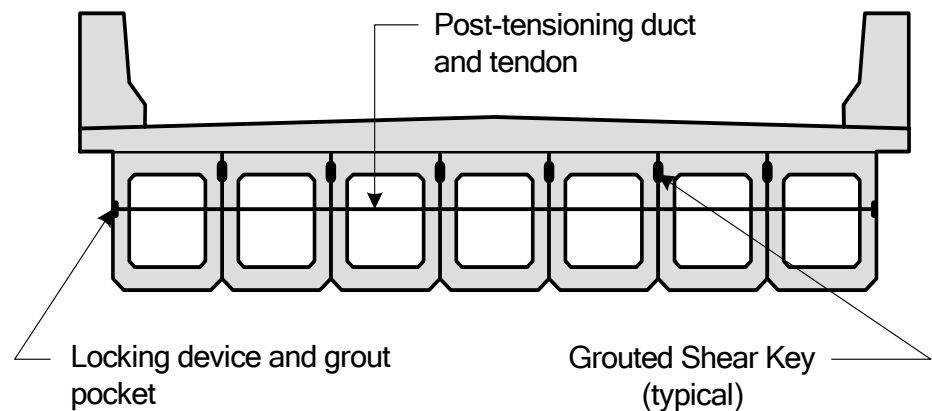

Figure 7.10.6 Transverse Post-tensioning of an Adjacent Box Beam Bridge

Spread Box Beams

On a spread box beam bridge, the box beams are usually spaced from 610 to 1830 mm (2 to 6 feet) apart and typically use a composite cast-in-place concrete deck (see Figure 7.10.7). This application is practical for span lengths from 8 to 26 m (25 to 85 feet). Stay-in-place forms or removable formwork is used between the box beams to provide a support when the concrete deck is placed.



Figure 7.10.7 Underside of a Typical Spread Box Beam

All modern box beams should have drain holes that are installed in the bottom slab during fabrication to allow any moisture in the void to escape.

Primary Members and Secondary Members

The primary members of box beam bridges are the concrete box beams. External diaphragms are the only secondary members on box beam bridges, and they are only found on spread box beam bridges (see Figure 7.10.8). The diaphragms may be cast-in-place, precast, or steel and are placed at either the mid points or third points along the span and at the span ends. End diaphragms can provide restraint and act as a backwall. End diaphragms are located at the abutments and piers and can be full or partial depth. Intermediate diaphragms are usually partial depth.



Figure 7.10.8 End and Intermediate Diaphragms on a Spread Box Beam Bridge

Internal Diaphragms are considered a part of the prestressed box beams and not a secondary member (see Figure 7.10.9).

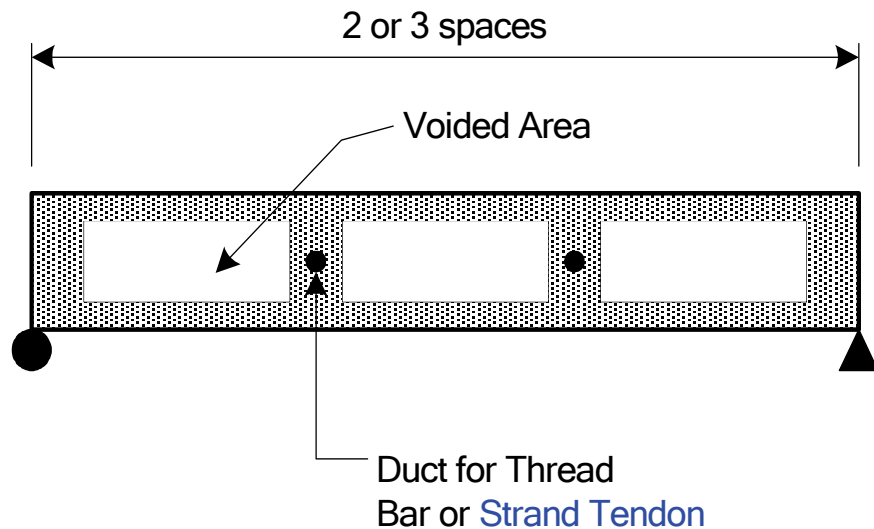

Figure 7.10.9 Schematic of Internal Diaphragms

Steel Reinforcement

Primary Reinforcement

Primary reinforcement consists of main tension steel and shear reinforcement or stirrups.

High Strength Steel

Main tension steel consists of high strength pretensioned prestressing strands placed in the flange and lower web of the box beam.

Depending on the age of the structure, the strand size will be 6, 10, 11 or 13 mm (1/4, 3/8, 7/16, or 1/2 inch) in diameter and spacing is normally 51 mm (2 inches) apart (see Figure 7.10.10). In some newer applications of prestressed box beams using HPC, 15mm (0.6-inch) strand sizes with a spacing of 51mm (2 inches) are used to fully implement the increased concrete strengths.

Mild Steel

Mild steel stirrups are placed vertically in the web at spacings required by design for shear reinforcement. Mild steel stirrups are more closely spaced near beam ends and typically grade 60.

Secondary Reinforcement

Transverse post-tensioning strands through the diaphragms helps maintain monolithic action between the adjacent box beams. Temperature and shrinkage reinforcement consisting of mild steel is placed longitudinal in the beam webs and top flange.

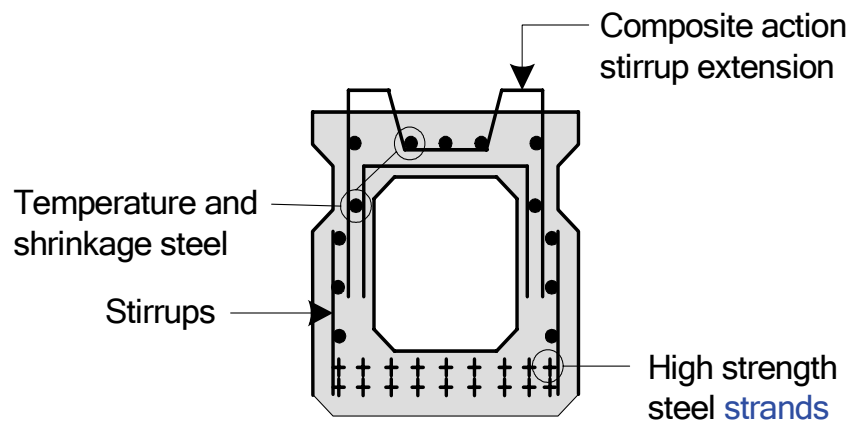

Figure 7.10.10 Typical Prestressed Box Beam Reinforcement

Fiber Reinforced Polymer Strands

Composite strands can be carbon fiber or glass fiber and are fairly new to the bridge prestressing industry. These strands are gaining acceptance due to the low corrosive properties compared to steel strands and will just be mentioned in this manual.

7.10.3

Overview of Common Defects

Common defects that occur on prestressed box beams include:

- Cracking (flexure, shear, temperature, shrinkage)
- Scaling
- Delamination
- Spalling
- Chloride contamination
- Efflorescence
- Ettringite formation

- Pop-outs
- Wear
- Collision damage
- Abrasion
- Overload damage
- Reinforcing steel corrosion
- Prestressed concrete deterioration
- Stress corrosion of prestressing strands

Refer to Topic 2.2 for a detailed presentation of the properties of concrete, types and causes of concrete deterioration, and the examination of concrete.

7.10.4

Inspection Procedures and Locations

Inspection procedures to determine other causes of concrete deterioration are discussed in detail in Topic 2.2.8.

Procedures

Visual

The inspection of prestressed concrete box beams for cracks, spalls, and other defects is primarily a visual activity.

Physical

Sounding by hammer can be used to detect delaminated areas. A delaminated area will have a distinctive hollow “clacking” sound when tapped with a hammer or revealed with a chain drag. A hammer hitting sound concrete will result in a solid "pinging" type sound. In most cases, a chain drag is used to check the top surface of an exposed top flange.

Since prestressed box beams are designed to limit tensile stresses in concrete to specified thresholds, cracks are indications of serious problems. For this reason, any crack should be carefully measured with an optical crack gauge or crack comparator card and documented.

Advanced Inspection Techniques

Several advanced techniques are available for concrete inspection. Nondestructive methods, described in Topic 13.2.2, include:

- Acoustic wave sonic/ultrasonic velocity measurements
- Delamination detection machinery
- Electrical methods
- Electromagnetic methods
- Pulse velocity
- Flat jack testing
- Ground-penetrating radar
- Impact-echo testing

SECTION 7: Inspection and Evaluation of Common Concrete Superstructures
TOPIC 7.10: Prestressed Box Beams

- Impact-echo testing
- Infrared thermography
- Laser ultrasonic testing
- Magnetic field disturbance
- Neutron probe for detection of chlorides
- Nuclear methods
- Pachometer
- Rebound and penetration methods
- Ultrasonic testing

Other methods, described in Topic 13.2.3, include:

- Core sampling
- Carbonation
- Concrete permeability
- Concrete strength
- Endoscopes and videoscopes
- Moisture content
- Petrographic examination
- Reinforcing steel strength
- Chloride test
- Matrix analysis
- ASR evaluation

Locations

Bearing Areas

Check bearing areas for concrete delaminations, spalls or vertical/horizontal cracks. Spalls and cracks may be caused by corrosion of steel reinforcement due to water leakage or restriction of thermal movement due to a faulty bearing mechanism. Delaminations, spalls and cracks may also be caused by the stresses created at the transfer of the prestressing forces (see Figure 7.10.11).

Check for rust stains, which indicate corrosion of steel reinforcement (see Figure 7.10.12).

Check the bottom of beams for longitudinal cracks originating from the bearing location. These cracks are sometimes caused by the unbalanced transfer of prestress force to the concrete, or by the accumulation of water inside the box, freezing and thawing (see Figure 7.10.13).



Figure 7.10.11 Spalled Beam Ends



Figure 7.10.12 Exposed Bars at End of Box Beam



Figure 7.10.13 Longitudinal Cracks in Bottom Flange of Beam

Shear Zone

Check beam ends and sections over piers for diagonal shear cracks in webs. These web cracks will project diagonally upward at approximately a 45 degree angle from the support toward midspan (see Figure 7.10.14).



Figure 7.10.14 Diagonal Shear Crack in Web of Beam

Tension Zones

Inspect the lower portion of the beam, particularly at mid span, for flexure cracks. This indicates a very serious problem resulting from overloading or loss of

prestress.

Check for delaminations, spalls and exposed reinforcing steel. Exposed strands fail prematurely due to stress corrosion (see Figure 7.10.15).

Check for deteriorated concrete, which could cause debonding of the tension reinforcement. This would include spalls, delaminations, and cracks.

Check bottom flange for longitudinal cracks which may indicate a deficiency of prestressing steel, or possibly an overloading of the concrete due to use of prestressing forces that are too large.

For continuous bridges, check the deck area over the supports for flexure cracks due to negative moment in the beam.

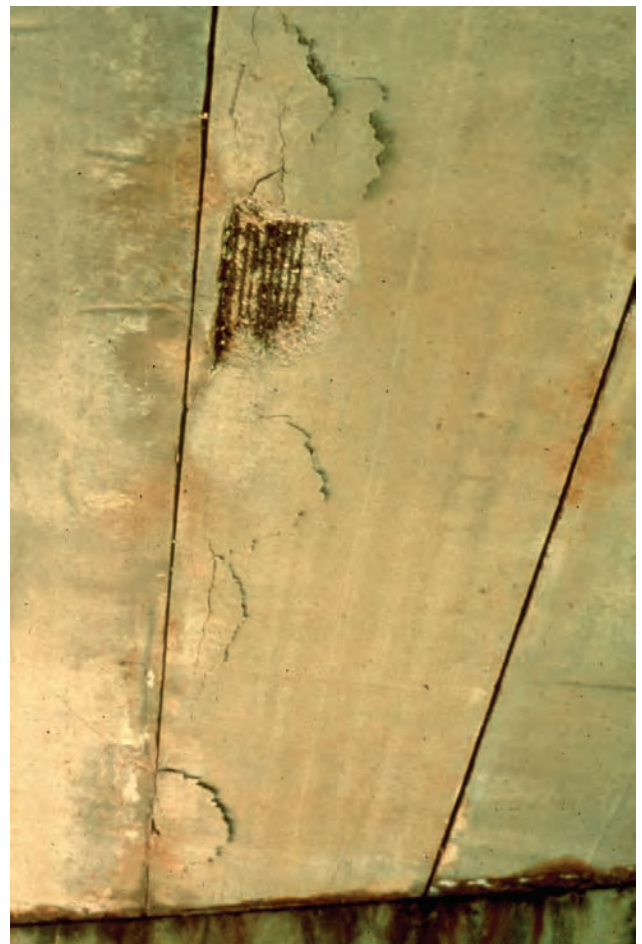

Figure 7.10.15 Spall and Exposed Reinforcement

Secondary Members

Inspect the end diaphragms of spread box beams for delaminations, spalling and cracking. Diagonal cracking is a possible sign of shear failure and can be caused by substructure movement.

Inspect the intermediate diaphragms of spread box beams for delaminations, spalls

and cracks. Flexure and shear cracks may indicate excessive differential beam deflection.

Areas Exposed to Drainage

Examine joints between adjacent box beams for leakage and rust stains. Look for reflective cracking in the traffic surface and differential beam deflection under live load. These problems indicate that the shear key between boxes has been broken and that the boxes are acting independently of each other (see Figure 7.10.16). These problems could also indicate the transverse post-tensioning is not acting as designed. The transverse post tensioning may have failed due to the leaking shear keys.

Check around scuppers and inlets for leaking water or deterioration of concrete. Check the underside of beam ends for leakage at the expansion joint areas and the fascia of exterior beams.

Check drain holes for proper function as accumulated water can freeze and crack the beam.



Figure 7.10.16 Joint Leakage and Rust Stain

Areas Exposed to Traffic

Check areas damaged by collision. A significant amount of prestressed concrete bridge deterioration and loss of section is due to traffic damage. Document the number of exposed and severed strands as well as the loss of concrete section. The loss of concrete due to such an accident is not always serious, unless the bond between the concrete and steel reinforcement is affected (see Figure 7.10.17).



Figure 7.10.17 Close-up of Collision Damage

Areas Previously Repaired

Examine thoroughly any repairs that have been previously made. Determine if repaired areas are functioning properly. Effective repairs and patching are usually limited to protection of exposed tendons and reinforcement.

General

Examine the sides of the beams for cracks. Adjacent box beam side surfaces are visible only on the fascias. For interior beams, inspect the bottom chamfers for cracks, which may extend along the sides of the beams.

Using a string line, check for horizontal alignment and camber of the prestressed beams. Downward deflection usually indicates loss of prestress or damage to the post-tensioning tendon. Upward deflection usually indicates extreme initial prestressing forces or shrinkage.

Note the presence of surface irregularities caused by burlap folds used in the old vacuum curing process. This dates the beam construction to the early 1950's and should alert the inspector to possible deficiencies common in early box beams, such as inadequate or non-existent drainage openings and strand cover (see Figure 7.10.18).

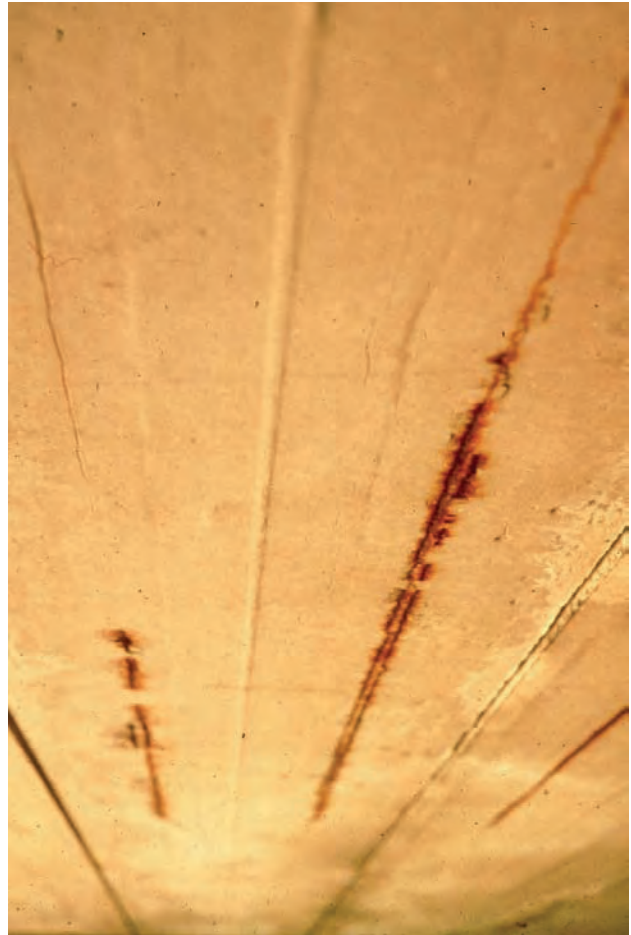

Figure 7.10.18 Burlap Fold Depressions in an Early 1950's P/S Box Beam

7.10.5

Evaluation

State and federal rating guideline systems have been developed to aid in the inspection of concrete superstructures. The two major rating guideline systems currently in use are the FHWA's *Recording and Coding Guide for the Structural Inventory and Appraisal of the Nation's Bridges* used for the National Bridge Inventory (NBI) component rating method and the AASHTO element level condition state assessment method.

NBI Rating Guidelines

Using NBI rating guidelines, a 1-digit code on the Federal Structure Inventory and Appraisal (SI&A) sheet indicates the condition of the superstructure. Rating codes range from 9 to 0, where 9 is the best rating possible. See Topic 4.2 (Items 58 and 59) for additional details about NBI Rating Guidelines for decks and superstructures.

The previous inspection data should be considered along with current inspection findings to determine the correct rating.

Element Level Condition State Assessment In an element level condition state assessment of a prestressed box beam bridge, the AASHTO CoRe element for the deck is one of the following, depending on the riding surface; plus Element No. 104.:

<u>Element No.</u>	<u>Description</u>
	Concrete Deck
012	Concrete Deck – Bare
013	Concrete Deck – Unprotected with AC Overlay
014	Concrete Deck – Protected with AC Overlay
018	Concrete Deck – Protected with Thin Overlay
022	Concrete Deck – Protected with Rigid Overlay
026	Concrete Deck – Protected with Coated Bars
027	Concrete Deck – Protected with Cathodic System
	P/S Box Girder
104	Prestressed Concrete Closed Girder/beam

For this bridge type, the box girder top flange acts as a structural deck and is supported by the box girder webs. The unit quantity for the deck elements is “each”, and the entire element must be placed in one of the five available condition states based solely on the top surface condition. Some states have elected to use the total deck area (m² or ft²). When a total area is used, the total area must be distributed among the five available condition states depending on the extent and severity of deterioration. The sum of all condition states must equal the total quantity of the CoRe element. The inspector must know the total deck surface area in order to calculate a percent deterioration and fit into a given condition state description. The unit quantity for the prestressed box beam is meters or feet, and the total length can be distributed among the four available condition states depending on the extent and severity of deterioration. Condition state 1 is the best possible rating. See the *AASHTO Guide for Commonly Recognized (CoRe) Structural Elements* for condition state descriptions.

A Smart Flag is used when a specific condition exists, which is not described in the CoRe element condition state. The severity of the damage is captured by coding the appropriate Smart Flag condition state. The Smart Flag quantities are measured as each, with only one each of any given Smart Flag per bridge.

For structural cracks in the top surface of bare decks, the “Deck Cracking” Smart Flag, Element No. 358, can be used and one of four condition states assigned. Do not use Smart Flag, Element No. 358, if the bridge deck/slab has any overlay because the top surface of the structural deck is not visible. Defects on the underside of a deck element are not visible in a box member. Therefore, the “Soffit” Smart Flag, Element No. 359, is not applicable. For damage due to traffic impact, the “Traffic Impact” Smart Flag, Element No. 362, can be used and one of three condition states assigned.

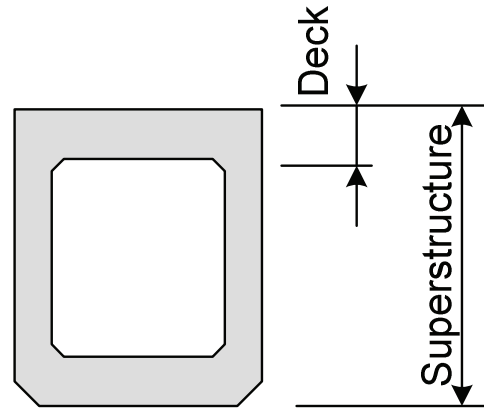

Figure 7.10.19 Components/Elements for Evaluation

Table of Contents

Section 7	
Inspection and Evaluation of Common Concrete Superstructures		
7.11 Concrete Box Girders.....		7.11.1
7.11.1 Introduction.....		7.11.1
7.11.2 Design Characteristics.....		7.11.2
Concrete Box Girder.....		7.11.2
Construction Methods.....		7.11.3
High Level Casting.....		7.11.3
At-grade Casting.....		7.11.4
Primary Members.....		7.11.5
Steel Reinforcement.....		7.11.5
Segmental Box Girder		7.11.7
Segment Configurations.....		7.11.9
Segmental Classification.....		7.11.10
Cast-in-place.....		7.11.10
Precast		7.11.10
Construction Methods.....		7.11.12
Balanced Cantilever		7.11.12
Span-by-span Construction		7.11.13
Progressive Placement Construction		7.11.16
Incremental Launching Construction		7.11.17
7.11.3 Overview of Common Defects		7.11.18
7.11.4 Inspection Procedures and Locations.....		7.11.18
Procedures		7.11.18
Visual.....		7.11.18
Physical		7.11.18
Advanced Inspection Techniques.....		7.11.19

SECTION 7: Inspection and Evaluation of Common Concrete Superstructures
TOPIC 7.11: Concrete Box Girders

Locations	7.11.19
Concrete Box Girder	7.11.19
Bearing Areas	7.11.20
Shear Zones	7.11.21
Tension Zones	7.11.21
Anchor Blocks	7.11.23
Secondary Members	7.11.23
Areas Exposed to Drainage	7.11.24
Areas Exposed to Traffic	7.11.24
Areas Previously Repaired	7.11.24
Miscellaneous Areas	7.11.24
Segmental Box Girder	7.11.28
Bearing Areas	7.11.28
Shear and Tension Zones	7.11.29
Anchor Blocks	7.11.30
Secondary Members	7.11.30
Joints	7.11.30
Internal Diaphragms	7.11.31
Areas Exposed to Drainage	7.11.32
Areas Exposed to Traffic	7.11.32
Areas Previously Repaired	7.11.32
Miscellaneous Areas	7.11.32
7.11.5 Evaluation	7.11.33
NBI Rating Guidelines	7.11.33
Element Level Condition State Assessment	7.11.33

Topic 7.11 Concrete Box Girders

7.11.1

Introduction

The popularity of box girder design is increasing. A trapezoidal box shape with cantilevered top flange extensions combines mild steel reinforcement and high strength post-tensioning tendons into a cross section capable of accommodating an entire roadway width. Both segmental and monolithic box girders are in service.

Older box girder bridges can be cast-in-place concrete with mild steel reinforcement and post-tensioning reinforcement (see Figures 7.11.1, 7.11.2 and 7.11.3). Current designs for concrete box girders typically use post-tensioning.

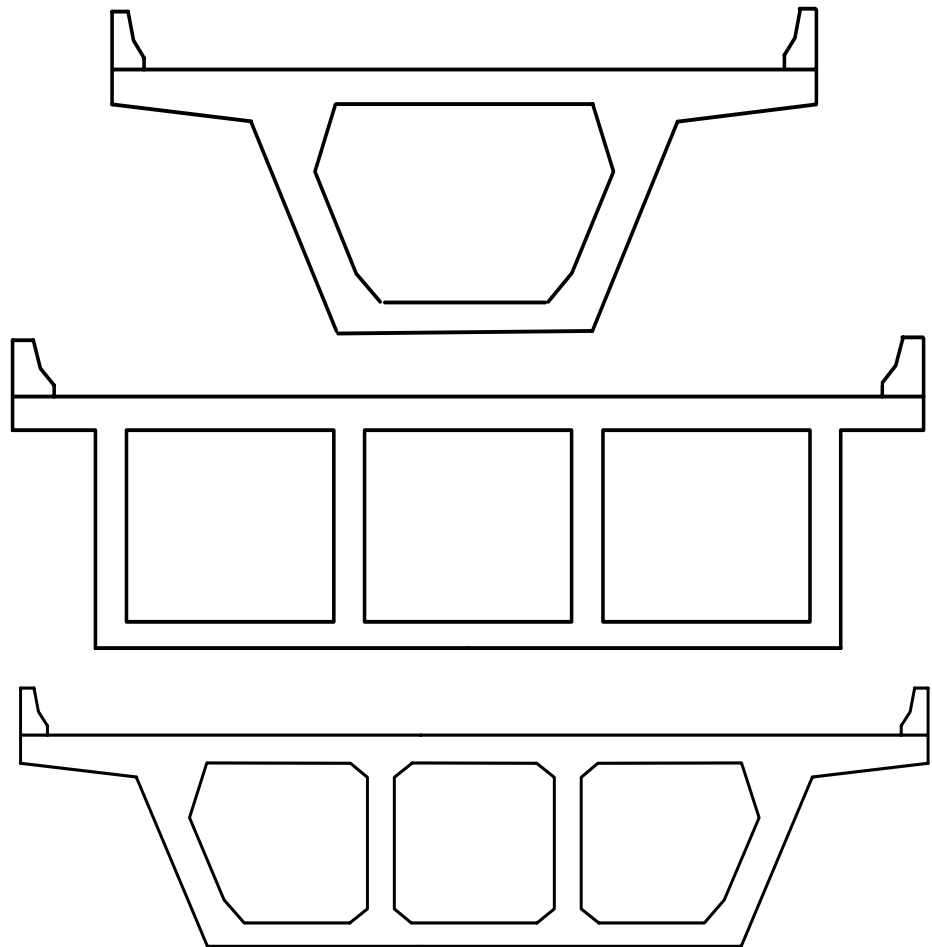

Figure 7.11.1 Typical Concrete Box Girder Cross Sections



Figure 7.11.2 Cast-in-place Concrete Box Girder Bridge

7.11.2

Design Characteristics

Concrete Box Girder For wide roadways, the box portion generally has internal webs and is referred to as a multi-cell box girder (see Figure 7.11.3). Concrete box girder bridges are typically either single span or continuous multi-span structures. Spans can have a straight or curved alignment and are generally in excess of 46 m (150 feet) (see Figure 7.11.4).

The following description applies to monolithic box girder construction only. A detailed description of segmental concrete bridges appears later in this Topic.

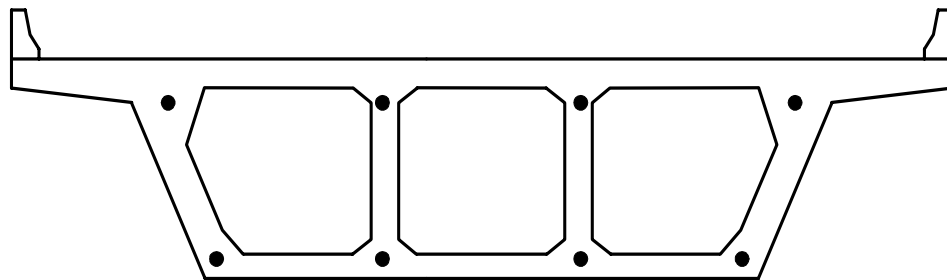

Figure 7.11.3 Multi-cell Girder: Post Tensioned



Figure 7.11.4 Cast-in-place Concrete Box Girder Bridge

Construction Methods

The two basic construction techniques used for cast-in-place monolithic box girders are high level casting and at-grade casting.

High Level Casting

The high level casting method employs formwork supported by falsework. This technique is used when the structure must cross an existing feature, such as a roadway, railway, or waterway (see Figure 7.11.5).



Figure 7.11.5 High Level Casting Formwork on Falsework

At-grade Casting

The at-grade casting method employs formwork supported by fill material or the existing ground. When the construction is complete, the fill beneath the bridge is removed. This technique is used when the structure is crossing, or is part of a new highway system or interchange (see Figures 7.11.6 and 7.11.7).



Figure 7.11.6 At-grade Formwork with Post-tensioning Ducts



Figure 7.11.7 Box Girder Bridge Construction

Primary Members

For box girder structures, the primary member is the box girder. When a single-cell box girder design is used, the top flange or deck, the bottom flange, and both webs are all primary elements of the box girder (see Figure 7.11.8). The top flange is considered an integral deck component/element.

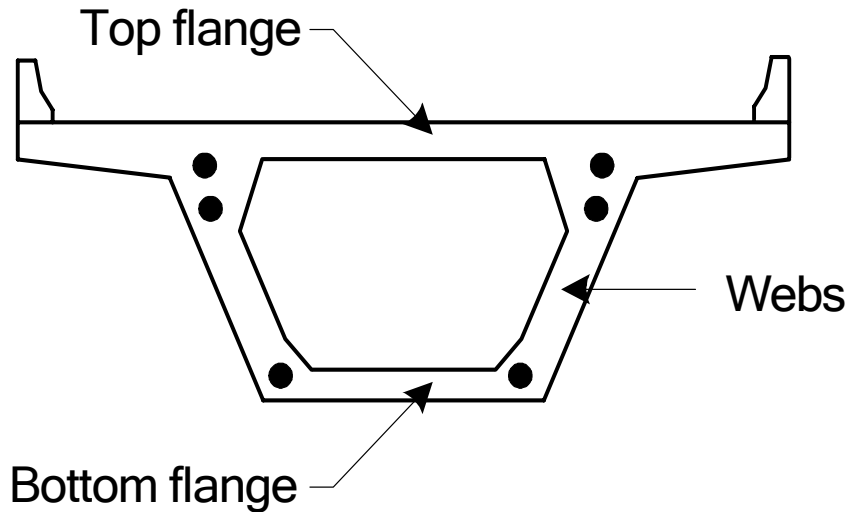

Figure 7.11.8 Basic Components/Elements of a Concrete Box Girder

In some multi-cell box girder applications, the top flange or deck must be removable for future replacement. The top flange in these cases functions similarly to a composite deck and is in fact considered a separate deck component. Most exterior webs have higher stress levels than interior webs. The interior webs of the box also play a significant role in the box girder and help support the deck (see Figure 7.11.9).

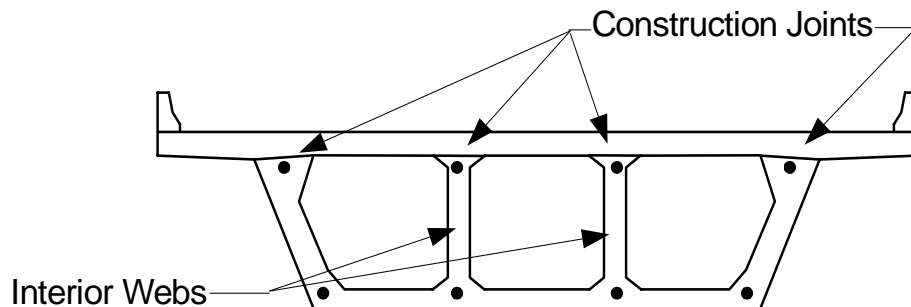

Figure 7.11.9 Replaceable Deck on a Multiple Cell Cast-in-place Box Girder

Steel Reinforcement

Box girder structures use a combination of primary mild steel reinforcement and high strength post-tensioning steel tendons to resist tension and shear forces (see Figure 7.11.10).

Flexure reinforcement is provided in the top and bottom flanges of the box girder as

necessary (bottom flange at midspan in areas of positive moment and top flange over supports in areas of negative moment). However, because of the design span lengths, mild steel reinforcement does not have sufficient strength to resist all of the tension forces. To reduce these tensile stresses to acceptable levels, prestressing of the concrete is introduced through post-tensioning. Galvanized metal and polyethylene ducts are placed in the forms at the desired location of the tendons. When the concrete has cured to an acceptable strength level, the tendons are installed in the ducts, tensioned, and then grouted (see Figure 7.11.6).

The top flanges or decks of precast or cast-in-place segmental boxes are often transversely post-tensioned. The multi-strand tendons are grouted after stressing. The tendons anchor in block-outs in the edges of top slab cantilever wings. These block-outs are then filled with concrete and covered with a traffic barrier. For precast units, the top flange tendons are generally tensioned and grouted in the casting yard. Wide bridges may have parallel twin boxes transversely post-tensioned. When this is the case, only about one-half of the transverse post-tensioning is stressed before shipment. The remainder of the post-tensioning is placed through ducts in adjacent box girders and the closure strip and stressed across the entire width of the bridge.

Special “confinement” reinforcement is also required at the anchorage locations to prevent cracking due to the large transfer of force to the surrounding concrete (see Figure 7.11.11).

Stirrups in the web are provided to resist standard beam action shear. For curved girder applications, torsional shear reinforcement is sometimes required. This reinforcement is provided in the form of additional stirrups.

The secondary (temperature and shrinkage) reinforcing steel is oriented longitudinally in the deck and webs and flanges in the box girder. The primary and secondary reinforcing steel for the deck portion of the girder is the same as for a standard concrete deck (see Figure 7.11.10).

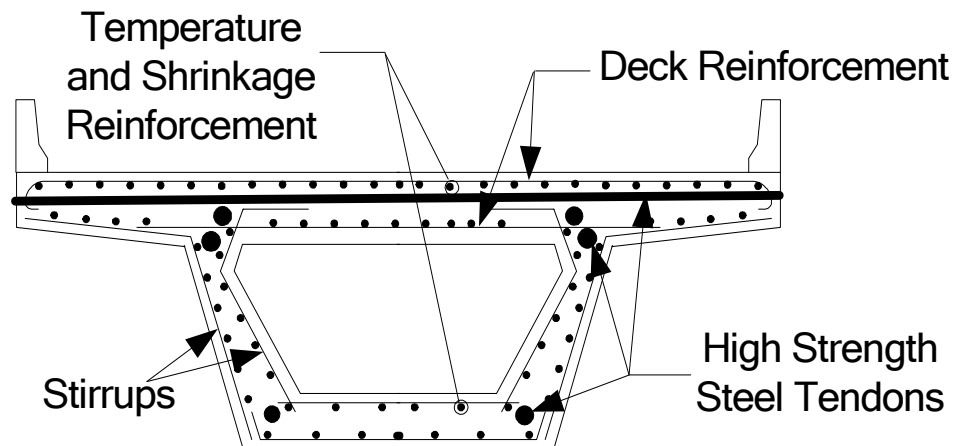

Figure 7.11.10 Primary and Secondary Reinforcement in a Concrete Box Girder



Figure 7.11.11 Formwork with Post-tensioning Anchorage and Spiral Anchorage Reinforcement

Segmental Box Girder

Many current box girders are built using segmental construction. A segmental concrete bridge is fabricated piece by piece. These pieces, or segments, are post-tensioned together during the construction of the bridge (see Figures 7.11.13 and 7.11.14). The superstructure can be constructed of precast concrete or cast-in-place concrete segments. Several characteristics are common to most segmental bridges:

- Used for long span bridges
- Used when falsework is undesirable or cost-prohibitive such as bridges over steep terrain or environmentally sensitive areas
- For most bridges, each segment is the full width and depth of the bridge; for very wide decks, many segmental box girders may consist of two-cell boxes or adjacent single boxes with a longitudinal cast-in-place concrete closure pour (see Figure 7.11.12)
- The length of the segments is determined by the construction methods and equipment available to the contractor
- Depending on the construction method, a new segment may be supported from previously erected segments



Figure 7.11.12 Adjacent Single Cell Boxes with Closure Pour



Figure 7.11.13 Segmental Concrete Bridge



Figure 7.11.14 Close-up of Segment

Segment Configurations

The majority of concrete segmental bridges use a box girder configuration (see Figure 7.11.15). The box girder is preferred due to the following:

- The top flange can be used as the roadway traffic surface (deck)
- The wide top and bottom flanges provide large areas to resist compression
- The box shape provides excellent torsional rigidity
- The box shape lends itself well to horizontally curved alignments

The typical box girder section will have the following elements:

- Top deck/flange
- Bottom flange
- Web walls
- Interior web walls (multi-cell)

Single box girder segments are usually used, although spread multiple boxes can be used if they are connected together by external diaphragms.

Segmental Classification

Individual segments can either be cast-in-place or precast concrete.

Cast-in-Place

Cast-in-place segmental construction is generally performed by supporting the segment formwork from the previous cast segment. Reinforcement and concrete is placed and the segment is cured. When the newly cast segment has reached sufficient strength, it is post-tensioned to the previous cast segments (see Figure 7.11.15). This process proceeds until the bridge is completed.



Figure 7.11.15 Cast-in-place Box Girder Segment

Precast

Precast segmental construction is performed by casting the individual segments prior to erecting them. The actual casting can take place near the project location or at an off-site fabrication plant. Once the precast segment is positioned adjacent to the previous placed segment, it is post-tensioned in the same manner as the cast-in-place segment previously mentioned. This process also repeats itself until the bridge is completed (see Figure 7.11.16).



Figure 7.11.16 Box Girder Segment

Precast construction lends itself well to repetitive operations and associated efficiencies. Fabrication plant operations also tend to offer higher degrees of quality control than field operations associated with cast-in-place construction. Precast construction must be monitored and controlled to ensure the proper fit in the field with regards to vertical and horizontal alignment. In order to control this situation, match casting is usually employed. Match casting utilizes the previous segment as part of the formwork for the next segment to ensure proper mating segments. Epoxy bonding adhesive is applied to the match-cast joints during initial erection.

Cast-in-place construction frequently does not benefit from the efficiencies of precast construction but does have the advantage of relatively easy field adjustments for controlling line and grade of alignment.

Construction Methods

Balanced Cantilever

This form of construction requires individual segments to be placed symmetrically about a pier. As the segments are alternately placed about the pier, the bending moments induced into the pier by the cantilever segments tend to balance each other. Once the mid-span is reached, a closure segment is cast together with the previously erected half-span from the adjacent pier. This procedure is repeated until all the spans have been erected (see Figures 7.11.17, 7.11.18 and 7.11.19). Both cast-in-place and precast construction is suitable for this form of construction.

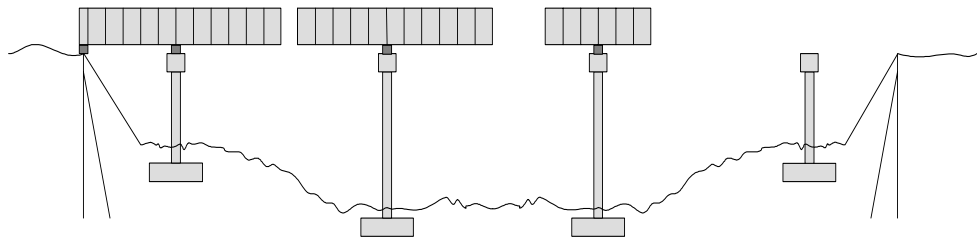

Figure 7.11.17 Balanced Cantilever Method



Figure 7.11.18 Balanced Cantilever Construction

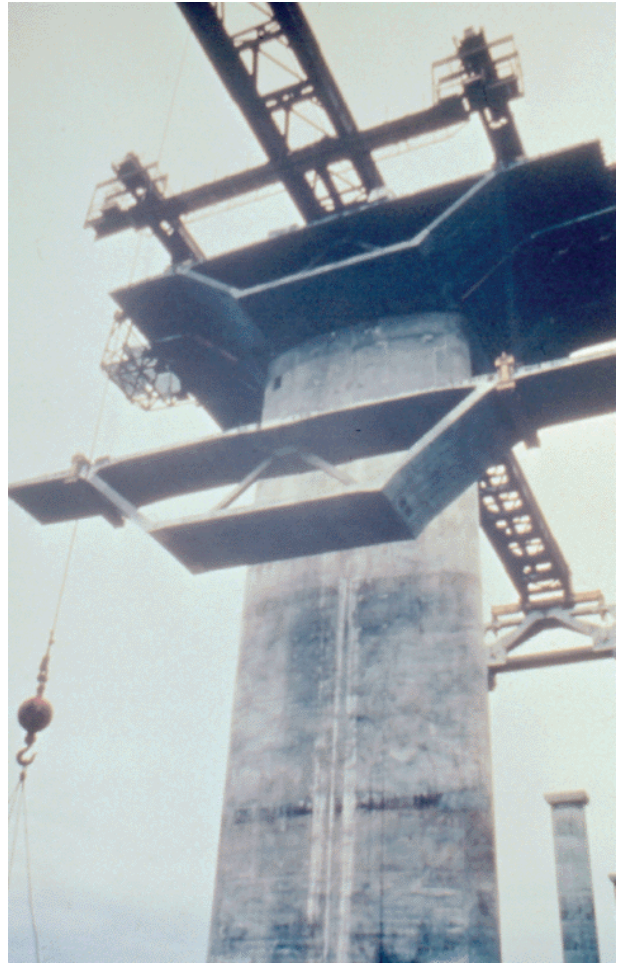

Figure 7.11.19 Balanced Cantilever Construction

Span-by-span Construction

This form of construction may require a temporary steel erection truss or falsework, which spans from one pier to another. The erection truss provides temporary support of the individual segments until they are positioned and post-tensioned into their final configuration. This type of construction allows a total span to be erected at one time. Once the span has been completed the erection truss is removed and repositioned on the next adjacent span. This procedure is repeated until all the spans have been erected (see Figures 7.11.20 and 7.11.21).



Figure 7.11.20 Span-by-Span Construction (with Erection Truss)



Figure 7.11.21 Span-by-span Close-up (with Erection Truss)

The entire span may also be assembled or cast on the ground, or on a floating barge. The span is raised to final position with cranes or lifting jacks and made continuous with the previously placed pier segments by closure pours and longitudinal post-tensioning. Both cast-in-place and precast construction is suitable for this form of construction (see Figure 7.11.22).

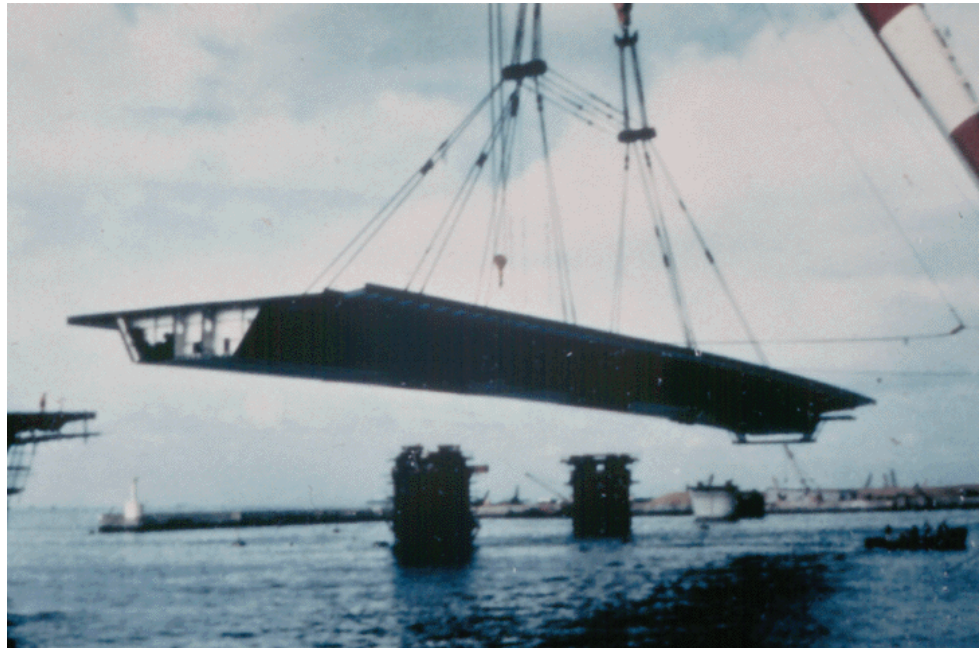

Figure 7.11.22 Span-by-span Total Span Erection (Lifting)

Progressive Placement Construction

This form of construction is much like the span-by-span construction described above. Construction proceeds outward from a pier towards an adjacent pier and once completed, the process is repeated in the next span and so on until the bridge is completed (see Figure 7.11.23). Because of the large bending forces associated with this type of construction, temporary bents or erection cables tied off to a temporary erection tower are often employed.



Figure 7.11.23 Progressive Placement Construction

Incremental Launching Construction

This form of construction permits the individual segments to be fabricated or positioned behind an abutment, post-tensioned, and then launched forward towards an adjacent pier by means of hydraulic jacks. Both cast-in-place and precast construction is suitable for this type of construction. This process is repeated until the entire bridge is constructed (see Figure 7.11.24).

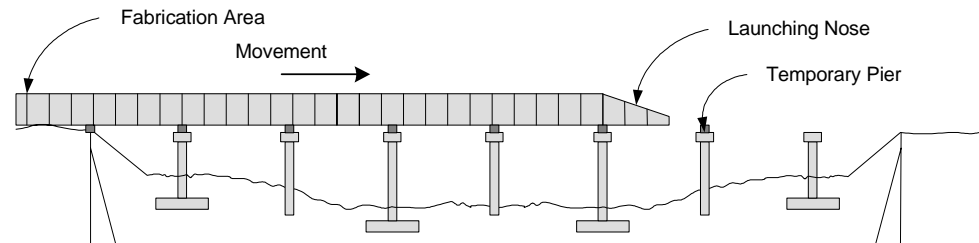

Figure 7.11.24 Incremental Launching Method

To aid the advancement and guide the already completed segments, a steel launching nose is attached to the leading segment. If the spans become very large, temporary bents are often used to reduce the large negative bending effects developed in the completed cantilever segments (see Figure 7.11.25).



Figure 7.11.25 Incremental Launching Overview (Note Temporary Pile Bent)

7.11.3

Overview of Common Defects

Common defects that occur on concrete box girder bridges include:

- Cracking (flexure, shear, temperature, shrinkage, mass concrete)
- Scaling
- Delamination
- Spalling
- Chloride contamination
- Efflorescence
- Ettringite formation
- Honeycombs
- Pop-outs
- Wear
- Collision damage
- Abrasion
- Overload damage
- Reinforcing steel corrosion
- Prestressed concrete deterioration
- Stress corrosion of prestressing strands

Refer to Topic 2.2 for a detailed explanation of the properties of concrete, types and causes of concrete deterioration, and the examination of concrete.

7.11.4

Inspection Procedures and Locations

Inspection procedures to determine other causes of concrete deterioration are discussed in detail in Topic 2.2.8.

Procedures

Visual

The inspection of prestressed concrete box girders for cracks, spalls, and other defects is primarily a visual activity.

Physical

Sounding by hammer can be used to detect delaminated areas. A delaminated area will have a distinctive hollow “clacking” sound when tapped with a hammer or revealed with a chain drag. A hammer hitting sound concrete will result in a solid “pinging” type sound. In most cases, a chain drag is used to check the top surface of a concrete deck.

Since prestressed box girders are designed to limit tensile stresses in concrete to specified thresholds, cracks are indications of serious problems. For this reason, any crack should be carefully measured with an optical crack gauge or crack comparator card and documented.

Advanced Inspection Techniques

Several advanced techniques are available for concrete inspection. Nondestructive methods, described in Topic 13.2.2, include:

- Acoustic wave sonic/ultrasonic velocity measurements
- Delamination detection machinery
- Electrical methods
- Electromagnetic methods
- Pulse velocity
- Flat jack testing
- Ground-penetrating radar
- Impact-echo testing
- Infrared thermography
- Laser ultrasonic testing
- Magnetic field disturbance
- Neutron probe for detection of chlorides
- Nuclear methods
- Pachometer
- Rebound and penetration methods
- Ultrasonic testing
- Radiography

Other methods, described in Topic 13.2.3, include:

- Core sampling
- Carbonation
- Concrete permeability
- Concrete strength
- Endoscopes and videoscopes
- Moisture content
- Petrographic examination
- Reinforcing steel strength
- Chloride test
- Matrix analysis
- ASR evaluation

Locations

Concrete Box Girder

The inspection of a box girder bridge requires a clear understanding of the girder function. This requires a thorough review of design or as-built drawings prior to the inspection and a realization of the high stress regions in a particular structure. Because of the complexities of box girders, many agencies develop an inspection and maintenance manual for a structure, which is written by the structural designer.

Arguably, the most important inspection a box girder will receive is the first or initial inspection. This inspection will serve as a benchmark for all future inspections.

Since the initial inspection is so important, it should be scheduled as early as possible after the construction of the bridge. Because of the complex nature of the box girder, all surfaces on the interior and exterior of the girder require visual examination.

Bearing Areas

Check the bearing area for delaminations, spalls and cracks. Delaminations, spalls and cracks may be caused by corrosion of steel reinforcement due to water leakage or restriction of thermal movements.

The effects of temperature, creep, and concrete shrinkage may produce undesirable conditions at the bearings. Check the bearing areas and the bearings for proper movement and movement capability (see Figure 7.11.26).



Figure 7.11.26 Bearing Area of a Cast-in-place Box Girder Bridge

Shear Zones

Check girder ends and sections over piers for diagonal shear cracks in webs. These web cracks will project diagonally upward at approximately a 45 degree angle from the support toward midspan (see Figure 7.11.27).

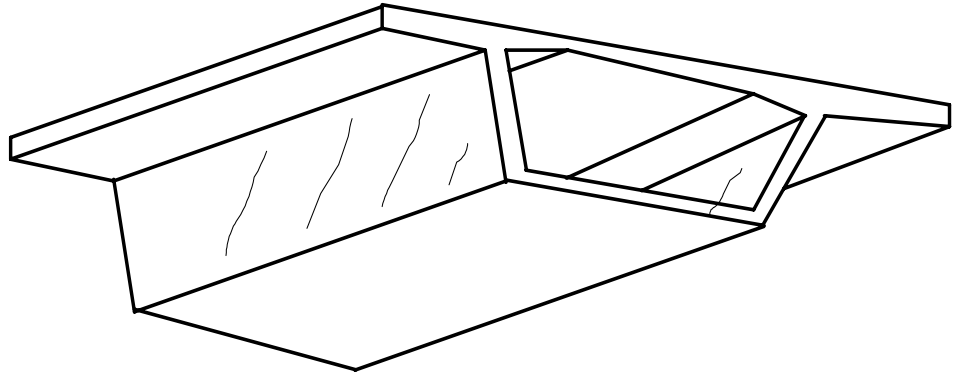

Figure 7.11.27 Box Girder Cracks Induced by Shear

Tension Zones

Direct Tension - Tension cracks can appear as a series of parallel cracks running transverse to the longitudinal axis of the bridge. The cracks can possibly be through the entire depth of the box girder section. Cracks will probably be spaced at approximately 1 to 2 times the minimum thickness of the girder component (see Figure 7.11.28).

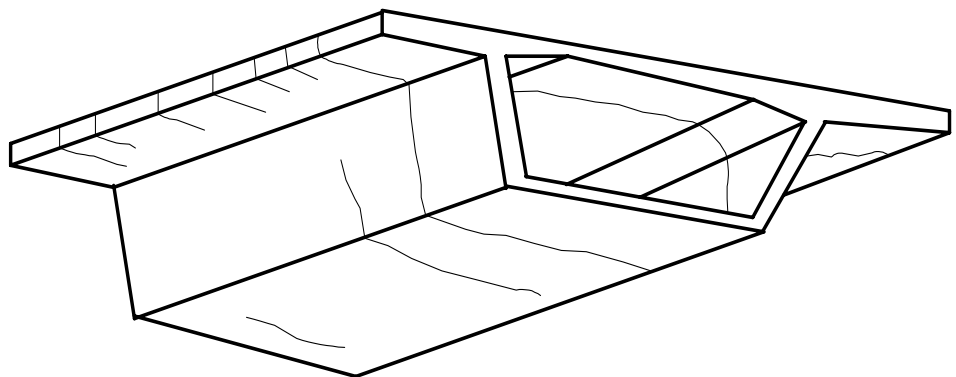

Figure 7.11.28 Box Girder Cracks Induced by Direct Tension

Flexure - These cracks can appear in the top flange at pier locations and on the bottom flange at mid-span regions. The extent of cracking will depend on the intensity of the bending being induced. Flexure cracks will normally propagate to the neutral axis or to an area around the half-depth of the section. Flexural cracks found in post-tensioned members should be examined very carefully. This could indicate that the member is overstressed. Accurately identify the location of the crack, the length and width of the crack, and the spacing to adjacent cracks (see Figures 7.11.29 and 7.11.30).

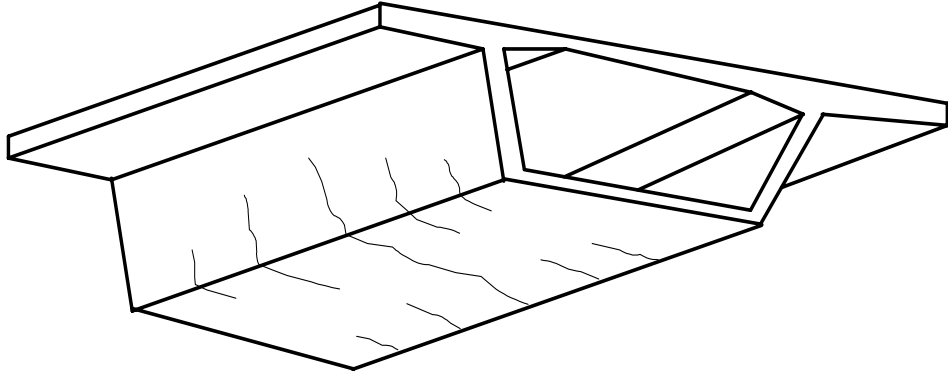

Figure 7.11.29 Box Girder Cracks Induced by Flexure (Positive Moment)

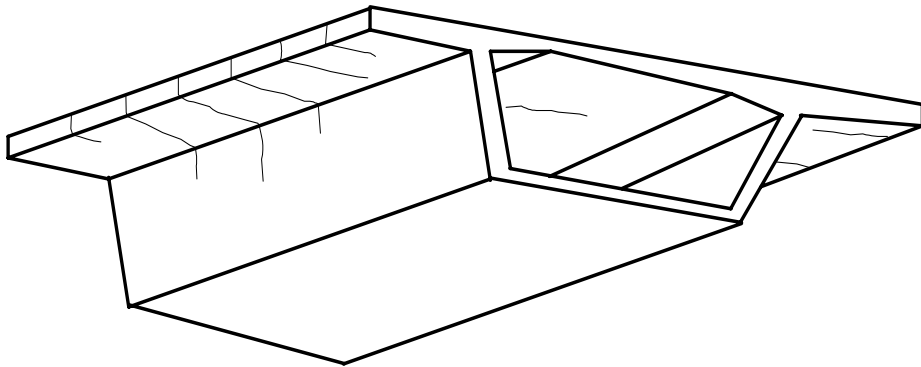

Figure 7.11.30 Box Girder Cracks Induced by Flexure (Negative Moment)

Flexure-shear - These cracks can appear close to pier support locations. They will begin on the bottom flange oriented transverse to the longitudinal axis of the bridge. The cracking will extend up the webs approximately 45 degrees to the horizontal and toward mid-span (see Figure 7.11.31).

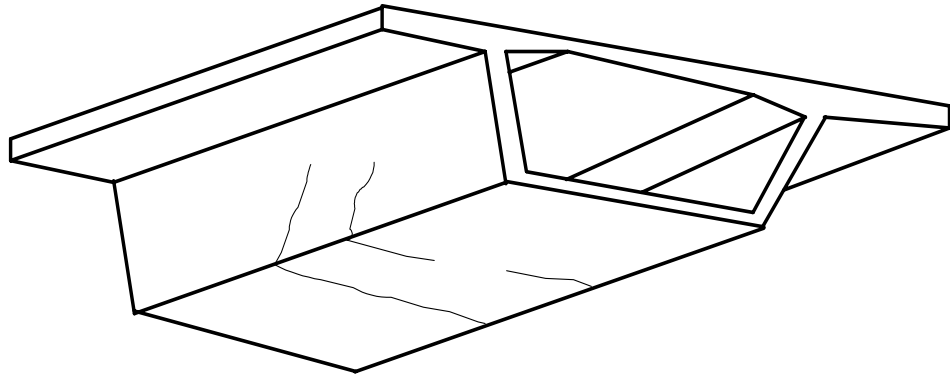

Figure 7.11.31 Box Girder Cracks Induced by Flexure-shear

Inspect the top side of the top flange for longitudinal flexure cracking directly over interior and exterior girder webs. Inside the box, examine the bottom of the top flange for longitudinal flexure cracking between the girder webs. These longitudinal cracks are caused by overstressing of the deck. Any efflorescence or leakage through the top flange should be documented.

The girder should be inspected throughout for flexure and shear cracks as well as prestress-induced cracks. Some shrinkage cracks are to be expected. Likewise, although post-tensioned, some small cracks may be present. As with all prestressed concrete members, any cracks should be carefully measured with an optical crack gauge or crack comparator and its location, length, width, and crack spacing documented.

Anchor Blocks

Anchor blocks contain the termination of the post-tensioning tendons. Very large concentrated loads are developed within these blocks. They have a tendency to crack if not properly reinforced or if there are voids adjacent to the post-tensioning tendons. The cracking will be more of a splitting failure in the web and would be oriented in the direction of the post-tensioning tendon (see Figure 7.11.32).

Secondary Members

If there are external diaphragms between the girders, check for delaminations, spalls and cracking. Defects on end diaphragms may indicate differential substructure settlement while defects in the intermediate diaphragms may indicate excessive deflection in the girders.

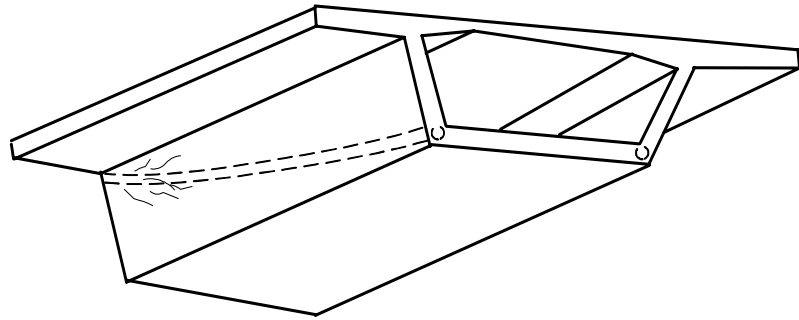

Figure 7.11.32 Web Splitting near an Anchorage Block

Areas Exposed to Drainage

Examine the girder for any delaminations, spalling, or scaling which may lead to exposure of reinforcing steel. Areas such as joints, scuppers and curb lines exposed to drainage should receive special attention.

Areas Exposed to Traffic

Check areas damaged by collision. A significant amount of concrete box girder bridge deterioration and loss of section is due to traffic damage. Document the number of exposed tendons, the length of exposed tendons, number of severed strands, the extent of, as well as the loss of, concrete section. The loss of concrete due to such a collision is not always serious, unless the bond between the concrete and steel reinforcement is affected.

Inspection of the roadway surface for delaminations, cracking, spalling, and deformation; the presence of these defects can increase the impact effect of traffic. This may be of greater significance if the top flange does not have an added wearing surface.

Areas Previously Repaired

Examine thoroughly any repairs that have been previously made. Determine if repaired areas are sound and functioning properly. Effective repairs and patching are usually limited to protection of exposed tendons and reinforcement.

Miscellaneous Areas

Cracks Caused by Torsion and Shear - This type of cracking will occur in both the flanges and webs of the box girder due to the twisting motion induced into the section. This cracking is very similar to shear cracking and will produce a helical configuration if torsion alone was present. Bridge structures most often will not experience torsion alone; rather bending, shear and torsion will occur simultaneously. In this event, cracking will be more pronounced on one side of the box due to the additive effects of all forces (see Figure 7.11.33).

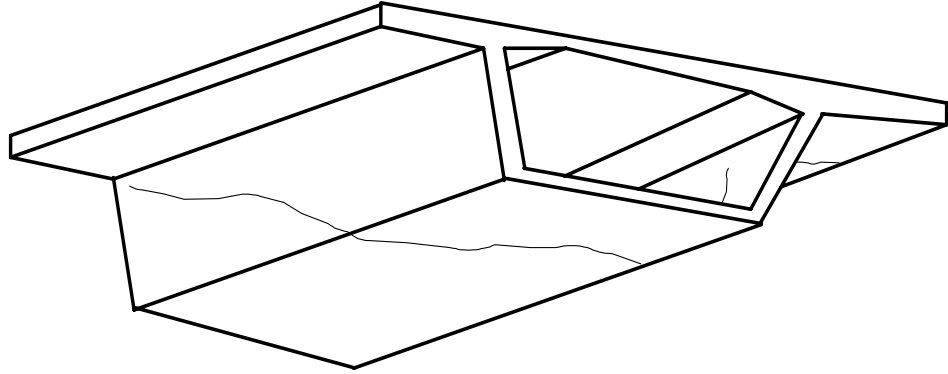

Figure 7.11.33 Box Girder Cracks Induced by Torsion and Shear

Thermal Effects - These cracks are caused by non-uniform temperatures between two surfaces located within the box girder. Cracking will typically be transverse in the thinner flanges of the box and longitudinal near changes in cross section thickness (see Figures 7.11.34 and 7.11.35).

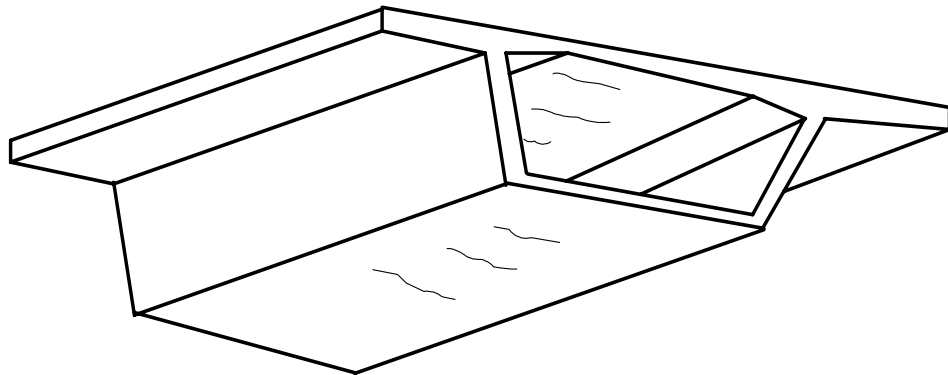

Figure 7.11.34 Thermally Induced Cracks in Box Girder Flanges

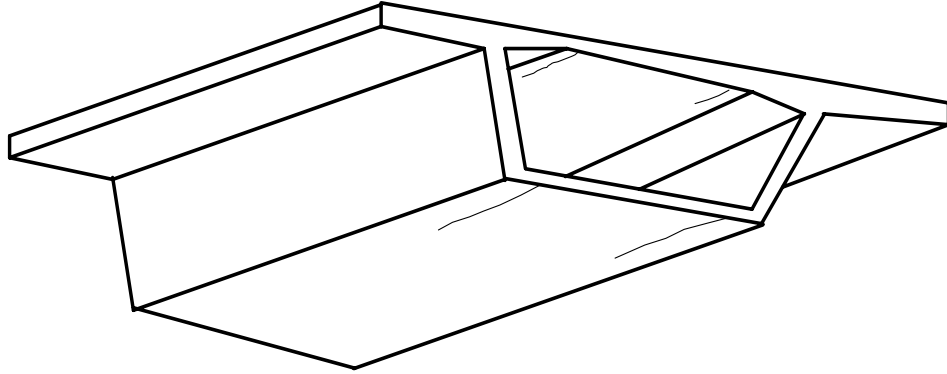

Figure 7.11.35 Thermally Induced Cracks at Change in Box Girder Cross Section

Post-tensioning - Cracking can occur along any of the lines of post-tensioning tendons. For this reason it is important for the inspector to be aware of where tendons are located in the box section (see Figure 7.11.36). This cracking may be the result of a bent tendon, a misaligned tendon with insufficient concrete cover or voids around the tendons. Shrinkage of concrete adjacent to large tendons has also caused this type of cracking.



Figure 7.11.36 Post-tensioning Tendon Duct

Overstress - Older cast-in-place box girder interiors should be inspected to verify that inside forms left in place do not provide unintentional load paths, which may result in overloading elements of the box (see Figure 7.11.37).



Figure 7.11.37 Interior Formwork Left in Place

Structure Alignment - An engineering survey needs to be performed at the completion of construction and a schedule for future surveys established. The results of these surveys will aid the bridge engineer in assessing the behavior and performance of the bridge. Permanent survey points at each substructure and at each mid-span should be established. Likewise, several points need to be set at each of these locations in the transverse direction across the deck (see Figure 7.11.38). During the inspection, the inspector should:

- Inspect the girder for the proper camber by sighting along the fascia of the bottom flange.
- On curved box girders, check for irregularities in the superelevation of the flanges, which could indicate torsional distress.

Radial Cracking - Post-tensioning tendons can be aligned vertical, horizontal or both depending on the vertical and horizontal geometry of the finished structure. The tendons produce a component of force normal to the curvature of their alignment. The result of this force can be cracking or spalling of the concrete components that contain these tendons. This type of distress is localized to the tendon in question, but can occur virtually anywhere along the length of the tendon. Joints of match cast precast segments are particularly sensitive to this type of cracking.

Investigate unusual noises, such as banging and screeching, which may be a sign of structural distress.

Observe and record data from any monitoring instrumentation (e.g., strain gauges, displacement meters, or transducers) that has been installed on or within the bridge.

Check the condition of the drainage holes to see if they are clear and functioning properly.

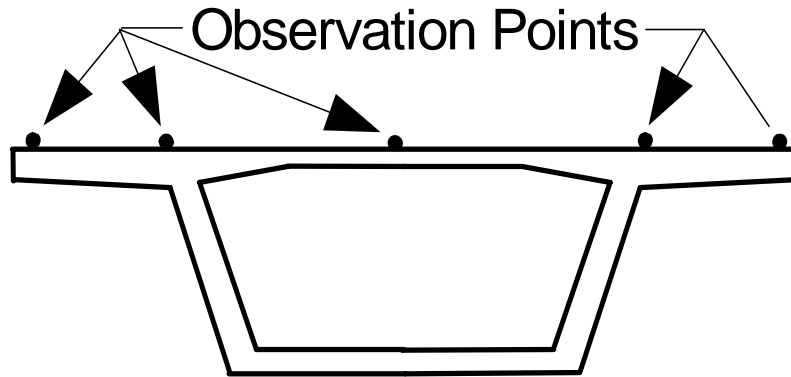

Figure 7.11.38 Location of Observation Points Across the Top Flange

Segmental Box Girder In addition to the inspection locations and procedures for concrete box girders, there are several special components that are unique to segmental bridges. The bridge inspector should be familiar with these special components.

Inspecting a segmental box girder bridge is similar to the procedures mentioned previously. This is described in Topic 2.2 and this format is consistent with similar topics for concrete box girders, and includes the following specific procedures:

Bearing Areas

Due to the inherent behavior of prestressed concrete structures, the effects of temperature, creep and shrinkage of the concrete may produce undesirable conditions to the bearings. These undesirable conditions take the form of distorted elastomeric bearings or loss of movement to mechanical bearings. Additionally, the areas where bearings interface with the bottom flange of the box girder need special attention. Large vertical forces from the superstructure are required to be transmitted to the bearings and, therefore, sizable bearing stresses are produced in these areas (see Figure 7.11.39).



Figure 7.11.39 Segmental Box Girder Bearings at Intermediate Pier

Shear and Tension Zones

Inspect both the interior and the exterior surfaces of the box girder. The inspection procedures for shear and tension zones in segmental box girder bridges are the same as for concrete box girder bridges. Examples of cracking in segmental box girder bridges are shown in Figures 7.11.27 to 7.11.35.

Anchor Blocks

Segmental construction relies on the tremendous post-tensioning forces to hold the individual segments together. Inspection of anchor blocks for segmental box girder bridges is the same as for concrete box girder bridges. Additionally, the inspection needs to focus on the box girder webs adjacent to the anchor blocks and look for the development of vertical cracks on either side of the anchors. Examine the condition of the tendons adjacent to the anchor blocks. The flange or web on which the anchor block is located will require attention concerning the potential for transverse cracking in the vicinity of the anchor (see Figures 7.11.40 and 7.11.42).

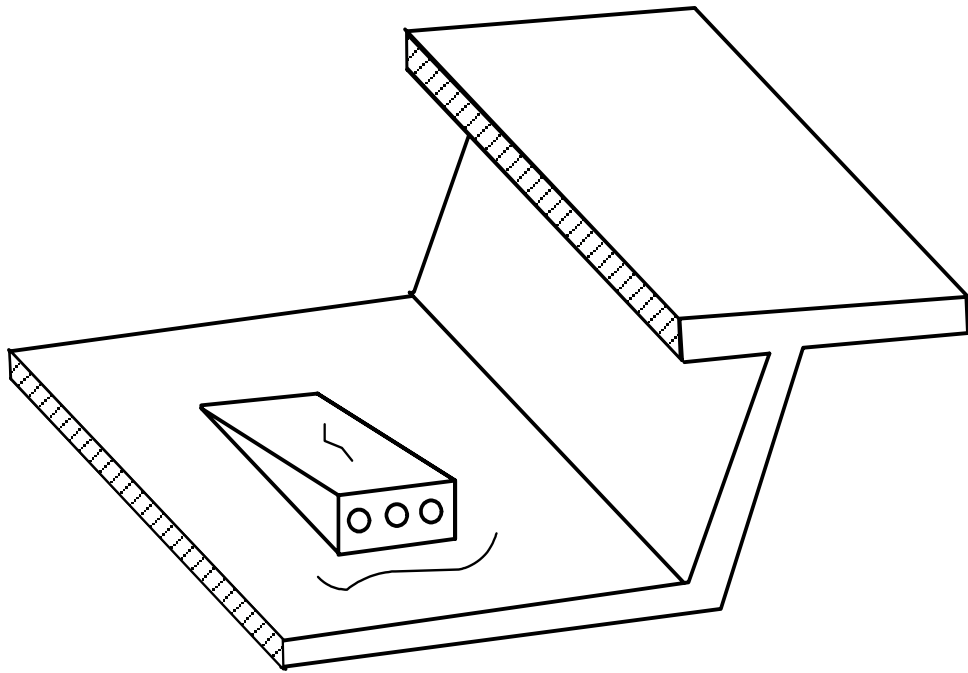

Figure 7.11.40 Segmental Box Girder Cracks Adjacent to Anchorage Block

Secondary Members

Internal diaphragms are located at abutments and piers and should receive close examination of the tendon anchorages located within them. The diaphragms stiffen the box section and distribute large bearing reaction loads. This region is highly stressed and should be examined closely for cracks.

If there are external diaphragms between the girders, check for cracking and spalling. Defects on end diaphragms may indicate differential substructure settlement while defects in the intermediate diaphragms may indicate excessive deflection in the girders.

Joints

Joints should be inspected for crushing and movement of the shear keys (see Figure 7.11.41). The presence of open or loose joints needs to be documented. Areas where the type of construction required closure joints or segments to be poured in place will

need close attention. These areas sometimes are regions of tendon anchorages and couplers. The stress concentrations in these areas are very much different than a section away from the anchorages where a distributed stress pattern exists (see Figure 7.11.42). Additionally, the effects of creep and tendon relaxation are somewhat higher in these regions.



Figure 7.11.41 Close-up View of Box Girder Shear Keys

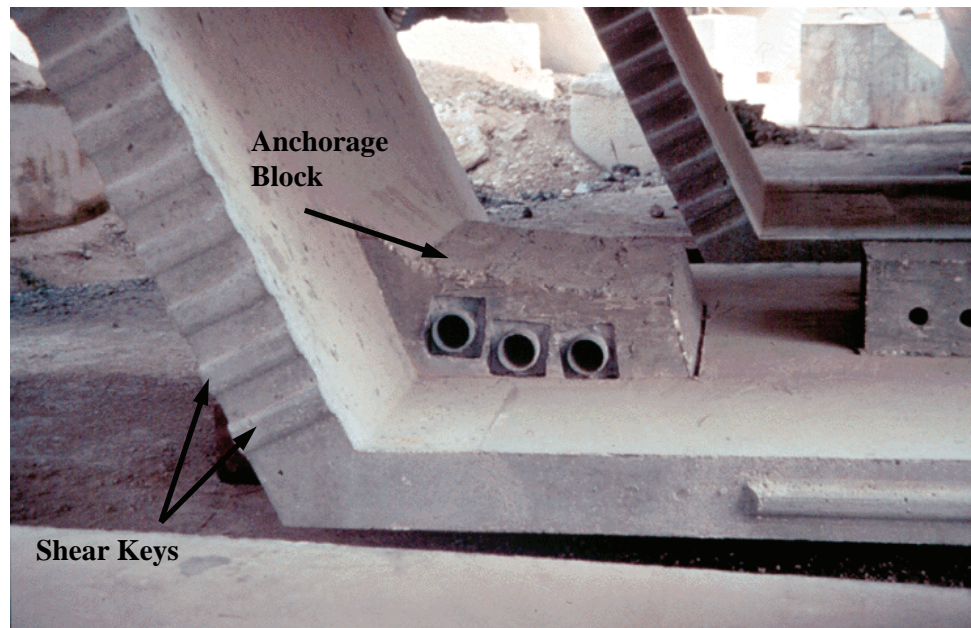

Figure 7.11.42 View of Box Girder Joint and Anchorage Block

Internal Diaphragms

Internal diaphragms at the piers and abutments serve to stiffen the box section and to distribute the large bearing reaction loads. Tendon anchorages located within the

diaphragm can also contribute to additional loads. This region of the structure is very highly stressed and, therefore, prone to crack development. The internal diaphragms require close examination during inspection (see Figure 7.11.43).



Figure 7.11.43 Box Girder Interior (End) Diaphragm

Areas Exposed to Drainage

Inspection of areas exposed to drainage is the same as those for concrete box girder bridges.

The joints between the segments should be closely examined for any signs of leakage or infiltration.

Areas Exposed to Traffic

Inspection of areas exposed to traffic is the same as those for concrete box girder bridges.

Areas Previously Repaired

Inspection of previous repairs is the same as those for concrete box girder bridges.

Miscellaneous Areas

Cracks caused by torsion and shear are the same as those for concrete box girder bridges.

Thermal Effects - The effects of temperature and the appropriate inspection procedures to accommodate for it is the same as those for concrete box girder bridges. Additionally, these cracks can also occur at component changes in thickness such as that between a web and a flange. In this case the cracking will occur at the juncture between these two elements.

For externally post-tensioned box girders, deviation blocks and blister blocks should be carefully examined for spalling and/or cracking distress (see Figure 7.11.44). These are points of very high stress concentrations and their integrity is essential to the integrity of span continuity post-tensioning. Locating and mapping areas of delaminations, spalling and delamination on the top flange is essential because of the structural importance of this component.



Figure 7.11.44 Inside View of Externally Post-tensioned Box Girder

7.11.5

Evaluation

State and federal rating guideline systems have been developed to aid in the inspection of concrete superstructures. The two major rating guideline systems currently in use are the FHWA's *Recording and Coding Guide for the Structural Inventory and Appraisal of the Nation's Bridges* used for the National Bridge Inventory (NBI) component rating method and the AASHTO element level condition state assessment method.

NBI Rating Guidelines Using NBI rating guidelines, a 1-digit code on the Federal Structure Inventory and Appraisal (SI&A) sheet indicates the condition of the superstructure. Rating codes range from 9 to 0, where 9 is the best rating possible. See Topic 4.2 (Items 58 and 59) for additional details about NBI Rating Guidelines.

The previous inspection data should be considered along with current inspection findings to determine the correct rating.

Element Level Condition State Assessment

In an element level condition state assessment of a concrete box girder bridge, the AASHTO CoRe element is one of the following, depending on the riding surface:

<u>Element No.</u>	<u>Description</u>
012	Concrete Deck – Bare

SECTION 7: Inspection and Evaluation of Common Concrete Superstructures
 TOPIC 7.11: Concrete Box Girders

013	Concrete Deck – Unprotected with AC Overlay
014	Concrete Deck – Protected with AC Overlay
018	Concrete Deck – Protected with Thin Overlay
022	Concrete Deck – Protected with Rigid Overlay
026	Concrete Deck – Protected with Coated Bars
027	Concrete Deck – Protected with Cathodic System

Concrete Box Girder

104	Prestressed Concrete Closed Web/Box Girder
105	Reinforced Concrete Closed Web/Box Girder

The unit quantity for the deck elements is “each”, and the entire element must be placed in one of the five available condition states based solely on the top surface condition. Some states have elected to use the total deck area (m² or ft²). When a total area is used, the total area must be distributed among the five available condition states depending on the extent and severity of deterioration. The sum of all condition states must equal the total quantity of the CoRe element. The inspector must know the total deck surface area in order to calculate a percent deterioration and fit into a given condition state description. The unit quantity for the girder is meters or feet, and the total length must be distributed among the four available condition states depending on the extent and severity of deterioration. Condition state 1 is the best possible rating. See the *AASHTO Guide for Commonly Recognized (CoRe) Structural Elements* for condition state descriptions.

A Smart Flag is used when a specific condition exists, which is not described in the CoRe element condition state. The severity of the damage is captured by coding the appropriate Smart Flag condition state. The Smart Flag quantities are measured as each, with only one each of any given Smart Flag per bridge.

For structural cracks in the top surface of concrete bare decks, the “Deck Cracking” Smart Flag, Element No. 358, can be used and one of four condition states assigned. Do not use Smart Flag, Element No. 358, if the bridge deck/slab has any overlay because the top surface of the structural deck is not visible. For concrete defects on the underside of a deck element, the “Soffit” Smart Flag, Element No. 359, can be used and one of five condition states assigned. For damage due to traffic impact, the “Traffic Impact” Smart Flag, Element No. 362, can be used and one of three condition states assigned.

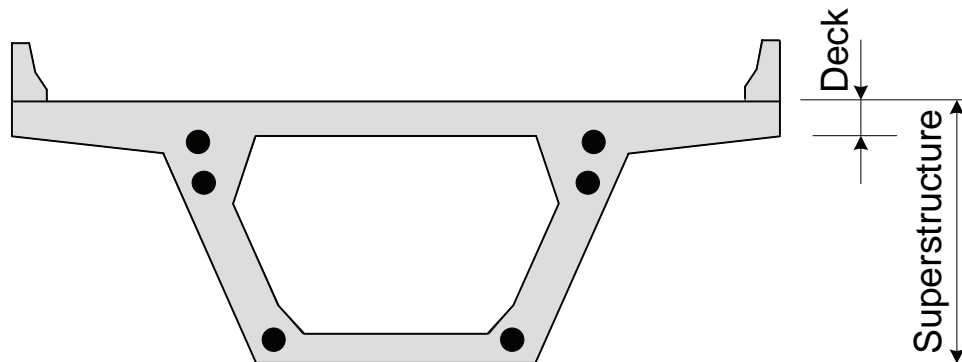

Figure 7.11.45 Components/Elements for Evaluation

Table of Contents

Section 7	
Inspection and Evaluation of Common Concrete Superstructures	
7.12 Concrete Box Culverts	7.12.1
7.12.1 Introduction.....	7.12.1
7.12.2 Design Characteristics.....	7.12.2
Loads on Concrete Box Culverts.....	7.12.2
Types of Box Culverts.....	7.12.3
Cast-in-place	7.12.3
Precast.....	7.12.3
Steel Reinforcement	7.12.4
Primary Reinforcement.....	7.12.4
Secondary Reinforcement.....	7.12.4
7.12.3 Overview of Common Defects	7.12.5
7.12.4 Inspection Procedures and Locations.....	7.12.5
Procedures	7.12.5
Visual	7.12.6
Physical.....	7.12.6
Advanced Inspection Techniques	7.12.6
Locations	7.12.7
Joints	7.12.7
Slabs and Walls.....	7.12.8
Weep Holes.....	7.12.9
7.12.5 Evaluation	7.12.10
NBI Rating Guidelines	7.12.10
Element Level Condition State Assessment.....	7.12.11

This page intentionally left blank

Topic 7.12 Concrete Box Culverts

7.12.1

Introduction

One of the most common types of culverts used today is the concrete box culvert (see Figure 7.12.1). A box culvert has an integral bottom slab that supports the side walls and provides a lined channel for the water to flow. The dimensions of the box culvert are determined by the peak flow of the channel. Box culverts are used in a variety of circumstances for both small and large channel openings and are easily adaptable to a wide range of site conditions, including sites that require low profile structures. In situations where the required size of the opening is very large, a multi-cell box culvert can be used (see Figure 7.12.2). It is important to note that although a box culvert may have multiple barrels, it is still a single structure. The internal walls are provided to reduce the unsupported length of the top slab.



Figure 7.12.1 Concrete Box Culvert



Figure 7.12.2 Multi-cell Concrete Box Culvert

7.12.2

Design Characteristics

Loads on Concrete Box Culverts

There are several basic loads applied in the design of a culvert (see Figure 7.12.3) and include:

- Dead loads (culvert self-weight)
- Vertical earth pressure (weight of earth such as fill and road surface)
- Horizontal (lateral) earth pressure
- Live loads (vehicular traffic, pedestrian traffic)

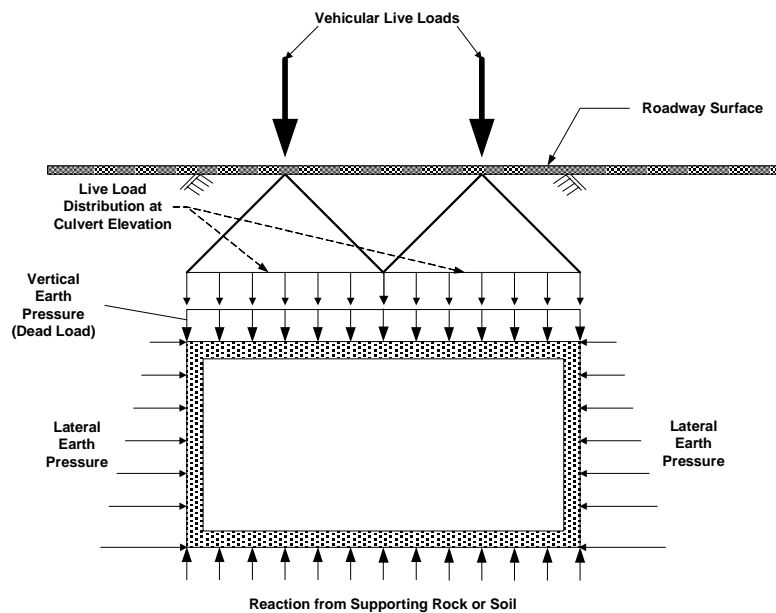

Figure 7.12.3 Loads on a Concrete Box Culvert

For a detailed description of loads on culverts, see Topic P.3.3.

Types of Box Culverts

There are two basic types of concrete box culverts – cast-in-place and precast. Several factors, such as span length, vertical clearance, peak stream flow, and terrain, determine which type of box culvert is used.

Cast-in-Place

Reinforced cast-in-place (CIP) concrete culverts are typically rectangular (box) shaped. The rectangular shape is usually constructed with multiple cells (barrels) to accommodate longer spans. The major advantage of cast-in-place construction is that the culvert can be designed to meet the specific geometric requirements of the site.

Precast

Precast concrete box culverts are designed for various depths of cover and various live loads and are manufactured in a wide range of sizes. Standard box sections are available with spans as large as 3.7 meters (12 feet). Some box sections may have spans of up to 6.1 meters (20 feet) if a special design is used.

ASTM C 1433 Precast Reinforced Concrete Box Sections for Culverts, Storm Drains and Sewers: Covers single-cell precast reinforced concrete box sections intended to be used for the construction of culverts for the conveyance of storm water and industrial wastes and sewage.



Figure 7.12.4 Precast Concrete Box Culvert

Steel Reinforcement

Primary Reinforcement

The primary reinforcing steel for box culverts consists of tension and shear steel. Tension steel is placed transversely in the slabs and vertically in the walls. Shear reinforcement may be placed diagonally in each of the corners (see Figure 7.12.5). Single cell precast concrete box culverts may use steel welded wire for reinforcement.

Secondary Reinforcement

Longitudinal temperature and shrinkage reinforcement is included in the slabs and the walls of box culverts. Ducts may be provided in the precast box sections for optional longitudinal post-tensioning of the boxes with high strength steel strands or bars (see Figure 7.12.6).

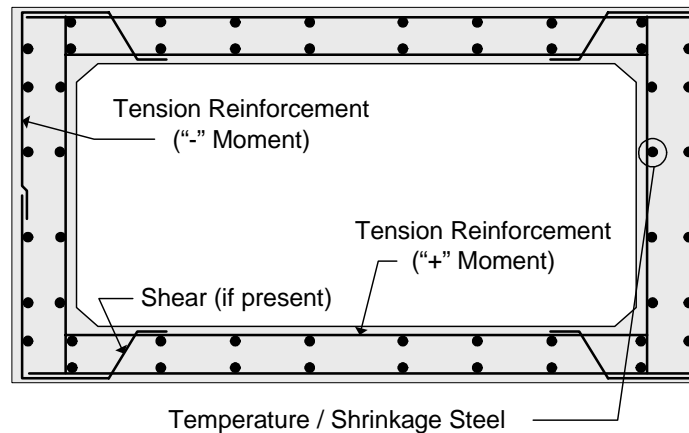

Figure 7.12.5 Steel Reinforcement in a Concrete Box Culvert

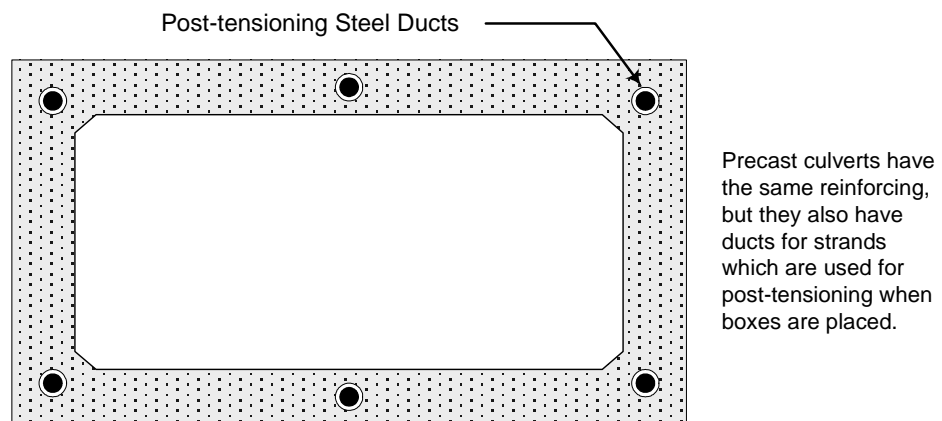

Figure 7.12.6 Precast Box Sections with Post-tensioning Steel Ducts

7.12.3

Overview of Common Defects

Common defects that occur in concrete box culverts include:

- Cracking (flexure, shear, temperature, shrinkage, mass concrete)
- Scaling
- Delamination
- Spalling
- Chloride contamination
- Efflorescence
- Ettringite formation
- Honeycombs
- Pop-outs
- Wear
- Collision damage
- Abrasion
- Overload damage
- Reinforcing steel corrosion
- Prestressed concrete deterioration
- Stress corrosion of prestressing strands
- Embankment scour at culvert inlet and outlet
- Roadway settlement

Refer to Topic 2.2 for a detailed explanation of the properties of concrete, types and causes of concrete deterioration, and the examination of concrete.

7.12.4

Inspection Procedures and Locations

See Topic P.3 for additional discussion on inspection procedures and locations for culverts.

Previous inspection reports and as-built plans, when available, should be reviewed prior to, and during, the field inspection. A review of previous reports will familiarize the inspector with the structure and make detection of changed conditions easier. Review of the previous inspection reports will also indicate critical areas that need special attention and the possible need for special equipment.

A logical sequence for inspecting culverts helps ensure that a thorough and complete inspection will be conducted. In addition to the culvert components, the inspector should also look for high-water marks, changes in the drainage area, settlement of the roadway, and other indications of potential problems. In this regard, the inspection of culverts is similar to the inspection of bridges.

Procedures

Inspection procedures to determine other causes of concrete deterioration are discussed in detail in Topic 2.2.8.

Visual

The inspection of concrete for cracks, spalls, and other defects is primarily a visual activity.

Physical

Hammer sounding of the exposed concrete should be performed to determine areas of delamination. A delaminated area will have a distinctive hollow “clacking” sound when tapped with a hammer or revealed with a chain drag. A hammer hitting sound concrete will result in a solid “pinging” type sound.

Advanced Inspection Techniques

Several advanced techniques are available for concrete inspection. Nondestructive methods, described in Topic 13.2.2, include:

- Acoustic wave sonic/ultrasonic velocity measurements
- Delamination detection machinery
- Electrical methods
- Electromagnetic methods
- Pulse velocity
- Flat jack testing
- Ground-penetrating radar
- Impact-echo testing
- Infrared thermography
- Laser ultrasonic testing
- Magnetic field disturbance
- Neutron probe for detection of chlorides
- Nuclear methods
- Pachometer
- Rebound and penetration methods
- Ultrasonic testing

Other methods, described in Topic 13.2.3, include:

- Core sampling
- Carbonation
- Concrete permeability
- Concrete strength
- Endoscopes and videoscopes
- Moisture content
- Petrographic examination
- Reinforcing steel strength
- Chloride test
- Matrix analysis
- ASR evaluation

Locations

For typical installations, it is usually convenient to begin the field inspection with general observations of the overall condition of the structure and inspection of the approach roadway. The inspector should inspect the embankment, waterway, headwalls, wingwalls at the inlet and outlet ends, and culvert barrel. The following sequence is applicable to all culvert inspections:

- Overall condition
- Approach roadway and embankment settlement
- Waterway (see in Topic 11.2)
- End treatments
- Appurtenance structures
- Culvert barrel

The following should be inspected inside the barrel of the box culvert.

- Joints – inspect joint locations for defects
- Slabs and walls – inspect slabs and walls for cracks, delaminations and spalls
- Weep holes

Joints

The vertical and horizontal alignment should be checked by visual observation. Vertical alignment should be checked for sags or differential settlement at joints. Sags can best be detected during low flows by looking for areas where the water is deeper or where sediment has been deposited. When excessive accumulations of sediment are present, it may be necessary to have the sediment removed before checking for sags. An alternate method would be to take profile elevations of the top slab. The horizontal alignment can be checked by sighting along the walls and by examining joints for differential movement (see Figure 7.12.7).

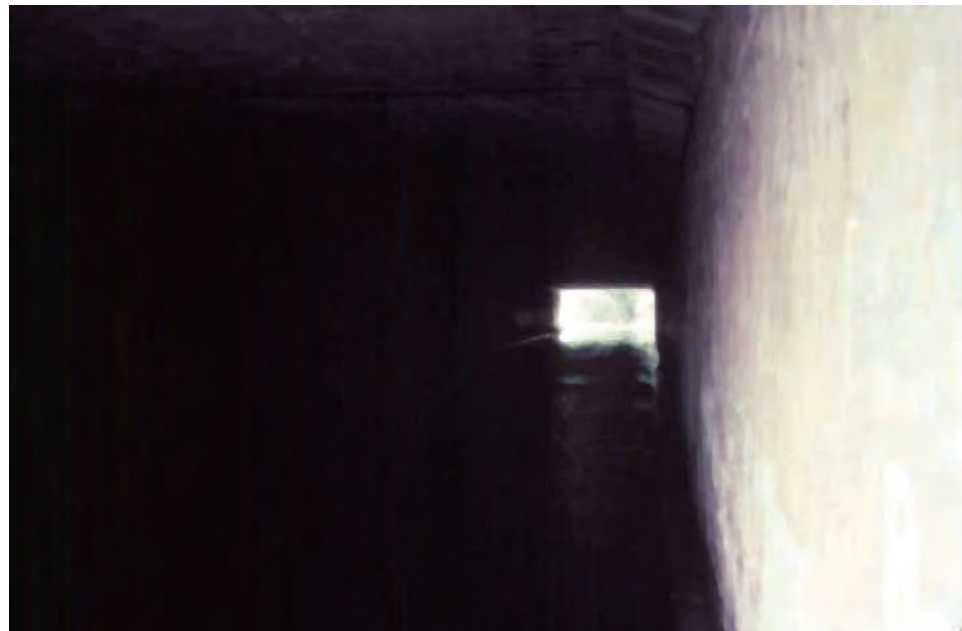

Figure 7.12.7 Sighting Along Culvert Sidewall to Check Horizontal Alignment

Expansion joints should be carefully inspected to verify that the filler material or joint sealant is in place and that the joint is not filled with incompressible material that would prohibit expansion (see figure 7.12.8). Spalls or cracks along joint edges are usually an indication that the expansion joint is full of incompressible materials or that one or more expansion joints are not working. Joint inspection also should identify any joints that are opened widely or are not open to uniform width. Water flowing or seeping into the culvert through open joints (infiltration) may bring with it supporting soil. Water flowing out of the culvert through open joints (exfiltration) may cause loss of supporting material.

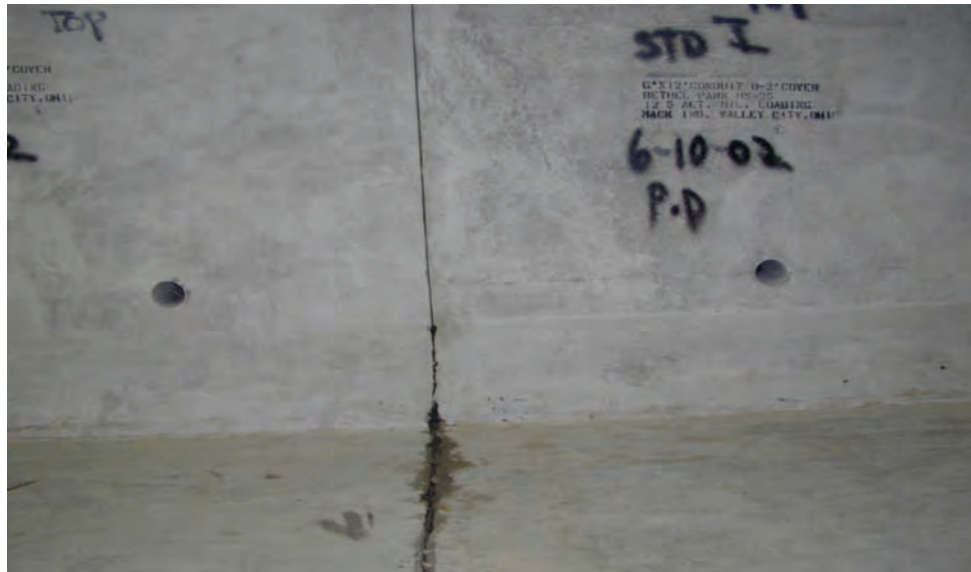

Figure 7.12.8 Precast Concrete Box Culvert Joint

Slabs and Walls

The top slab and walls should be inspected visually for cracks and spalls. When either is observed, the area around the defect should be tapped with a hammer to detect delaminations. A ladder may be needed for inspecting the top slab. Longitudinal cracks (along the length of the culvert) in the top slab of box culverts may indicate either flexure or shear problems. Transverse cracks may indicate differential settlement. Longitudinal cracks may also indicate differential wall settlement, or structural overloading. Transverse cracks in the top slab (perpendicular to walls) indicate differential settlement of the culvert. Spalls may occur along the edges of cracks or in the concrete covering corroded reinforcing steel. Cracks in the sides may be caused by settlement or earth pressure. The location, width, and length of all cracks and spalls should be noted in the inspection report as well as crack spacing.

The concrete surfaces exposed to stream flow should be checked by visual and physical procedures for unsound concrete due to chemical attack or abrasion. The bottom of the top slab, the bottom slab, and the water line on the walls are the most likely areas to be damaged.



Figure 7.12.9 Cast in Place Concrete Box Culvert Outlet



Figure 7.12.10 Spalls and Delaminations

Weep Holes

Weep holes are often provided on the side walls and wingwalls to drain water from the backfill and reduce the hydraulic pressure on the side walls. Weep holes should be inspected to determine if they are functioning properly. Lack of flow during periods when flow has previously been observed may indicate blockage. Fines on the bottom slab also indicate improper functioning.

7.12.5

Evaluation

State and federal rating guideline systems have been developed to aid in the inspection of concrete box culverts. The two major rating guideline systems currently in use are the FHWA's *Recording and Coding Guide for the Structural Inventory and Appraisal of the Nation's Bridges* used for the National Bridge Inventory (NBI) component rating method and the AASHTO element level condition state assessment method.

NBI Rating Guidelines Using NBI rating guidelines, a 1-digit code on the Federal Structure Inventory and Appraisal (SI&A) sheet indicates the condition of the culvert (Item 62). This item evaluates the alignment, settlement, joints, structural condition, scour, and other items associated with culverts. Rating codes range from 9 to 0, where 9 is the best rating possible. See Topic 4.2 (Item 62) for additional details about NBI Rating Guidelines. It is also important to note that Items 58-Deck, 59-Superstructure, and 60-Substructure should be coded "N" for all culverts.

General NBI bridge rating guidelines are applicable but are supplemented by NBI guidelines created for culvert structures as well as the specific concrete box culvert rating guidelines shown in Figure 7.12.11. The final culvert component rating assigned should accurately reflect both specific and general guidelines.

For concrete box culverts, the NBI rating guidelines yield a 1-digit code on the Federal (SI&A) sheet that indicates the overall condition of the culvert. The culvert item not only evaluates the structural condition of the culvert, but also encompasses the alignment, settlement in the approach roadway and embankment, joints, scour, and headwalls and wingwalls. Integral wingwalls are included in the evaluation up to the first construction or expansion joint. The 1-digit code that best describes the culvert's overall condition is chosen, and the rating codes range from 9 to 0, where 9 is the highest possible rating.

The previous inspection data should be considered along with current inspection findings to determine the correct rating.

**Element Level
Condition State
Assessment**

In an element level condition state assessment of a concrete box culvert, the AASHTO CoRe element is:

<u>Element No.</u>	<u>Description</u>
241	Reinforced Concrete Culvert

The unit quantity for culverts is meters or feet of culvert length along the barrel. The total quantity equals the culvert length times the number of barrels. The inspector must visually evaluate each 1 m (1 ft) slice of the culvert barrel(s) and assign the appropriate condition state description. The total length can be distributed among the four available condition states depending on the extent and severity of deterioration. Condition state 1 is the best possible rating. See the *AASHTO Guide for Commonly Recognized (CoRe) Structural Elements* for condition state descriptions.

A Smart Flag is used when a specific condition exists, which is not described in the CoRe element condition state. The severity of the damage is captured by coding the appropriate Smart Flag condition state. The Smart Flag quantities are measured as each, with only one each of any given Smart Flag per bridge.

Smart Flag element numbers available for use in concrete box culverts are Element 360 "Settlement" and Element 361 "Scour". One of the three condition states is chosen for each Smart Flag element that is used.

SECTION 7: Inspection and Evaluation of Common Concrete Superstructures
TOPIC 7.12: Concrete Box Culverts

<u>Code</u>	<u>Description</u>
N	Not applicable. Use if structure is not a culvert.
9	No deficiencies.
8	No noticeable or noteworthy deficiencies which affect the condition of the culvert. Insignificant scrape marks caused by drift.
7	Shrinkage cracks, light scaling, and insignificant spalling which does not expose reinforcing steel. Insignificant damage caused by drift with no misalignment and not requiring corrective action. Some minor scouring has occurred near curtain walls, wingwalls, or pipes. Metal culverts have a smooth symmetrical curvature with superficial corrosion and no pitting.
6	Deterioration or initial disintegration, minor chloride contamination, cracking with some leaching, or spalls on concrete or masonry walls and slabs. Local minor scouring at curtain walls, wingwalls, or pipes. Metal culverts have a smooth curvature, non-symmetrical shape, significant corrosion, or moderate pitting.
5	Moderate to major deterioration or disintegration, extensive cracking and leaching, or spalls on concrete or masonry walls and slabs. Minor settlement or misalignment. Noticeable scouring or erosion at curtain walls, wingwalls, or pipes. Metal culverts have significant distortion and deflection in one section, significant corrosion or deep pitting.
4	Large spalls, heavy scaling, wide cracks, considerable efflorescence, or opened construction joint permitting loss of backfill. Considerable settlement or misalignment. Considerable scouring or erosion at curtain walls, wingwalls, or pipes. Metal culverts have significant distortion and deflection throughout, extensive corrosion or deep pitting.
3	Any condition described in Code 4 but which is excessive in scope. Severe movement or differential settlement of the segments, or loss of fill. Holes may exist in walls or slabs. Integral wingwalls nearly severed from culvert. Severe scour or erosion at curtain walls, wingwalls, or pipes. Metal culverts have extreme distortion and deflection in one section, extensive corrosion, or deep pitting with scattered perforations.
2	Integral wingwalls collapsed, severe settlement of roadway due to loss of fill. Section of culvert may have failed and can no longer support embankment. Complete undermining at curtain walls and pipes. Corrective action required to maintain traffic. Metal culverts have extreme distortion and deflection throughout with extensive perforations due to corrosion.
1	Bridge closed. Corrective action may put bridge back in light service.
0	Bridge closed. Replacement necessary.

Figure 7.12.11 NBI Condition Rating Guidelines for Culverts