



Online Continuing Education for Professional Engineers
Since 2009

Introduction to HVAC Hydronics Systems

PDH Credits:

4 PDH

Course No.:

HHC101

Publication Source:

US Corp of Engineers

"HVAC Hydronics Systems"

Pub: # USACE/RL-TR-99/20

DISCLAIMER:

All course materials available on this website are not to be construed as a representation or warranty on the part of Online-PDH, or other persons and/or organizations named herein. All course literature is for reference purposes only, and should not be used as a substitute for competent, professional engineering council. Use or application of any information herein, should be done so at the discretion of a licensed professional engineer in that given field of expertise. Any person(s) making use of this information, herein, does so at their own risk and assumes any and all liabilities arising therefrom.

HVAC

HYDRONIC SYSTEMS

Contents

1	Introduction	E-5
	Purpose of Heating and Cooling Systems	E-5
	Outdoor Conditions	E-6
	Basic Hydronic Systems	E-6
	Heating	E-6
	Cooling	E-8
2	Air Control in Hydronic Systems	E-10
	Once-Through and Recirculating Systems	E-10
	Open and Closed Systems	E-10
	Mechanical Seals	E-11
	Manual Air Vents	E-11
3	Components of Hydronic Systems	E-13
	Component Locations	E-13
	Air Separator	E-13
	Flow Control Valve	E-15
	Circulator Valve	E-16
	Balancing Elbow and Balancing Fitting	E-17
	Vent Tee	E-17
	Expansion Type Air Vent	E-17
	Diverter Fitting	E-18
	Float Type Vent	E-18
	Hydronic Circulators	E-20
	Pressure Relief Valve	E-20
	Pressure Reducing Valve	E-21
	Expansion Tank	E-22
4	Piping Methods	E-23
	Water System Piping Classification	E-23
	Circuits for Small Systems	E-23
	Main Distribution Piping	E-24
	Pipe Circuit Types	E-24

Series Loop System	E-24
One-Pipe Systems	E-25
Two-Pipe Systems	E-26
Three-Pipe Systems	E-27
Four-Pipe Systems	E-27
5 Terminal Equipment	E-29
Cooling Equipment	E-29
Unit Room Coolers	E-30
Vertical units	E-30
Horizontal units	E-32
Unit Space Coolers	E-33
Air Handling Units	E-33
Heating Equipment	E-34
Perimeter Radiation	E-35
Baseboard radiation	E-35
Along-the-wall radiation	E-36
Heating Coils	E-37
Blower Unit Heaters	E-37
Convectors	E-38
Forced Convection Space Heating Equipment	E-38
6 Hydronic Pumps	E-40
Pump Types	E-40
Circulators	E-42
Close Coupled Centrifugal Pumps	E-42
Horizontal Base Mounted Pumps	E-43
Horizontal Split Case Pump	E-43
Centrifugal Pump Components	E-44
Cavitation	E-45
Pump Installation Considerations	E-46
Pumping in Parallel	E-46
Pumping in Series	E-47
7 Acceptance Testing	E-48
Acceptance Testing Checklist	E-48

Coils and Heat Exchangers	E-48
Pumps	E-48
Basic Hydronic System TAB Procedures	E-52
Glossary	E-55
Bibliography	E-57

1 Introduction

The science of heating and cooling with water is known as hydronics. Through years of advancement in technology, it is believed that water is still the most practical, economical, and ecologically safe heat transfer medium. The term hydronics should not be confused with hydraulics, which is the study of fluids in motion or at rest. The scope of this presentation on hydronics is to discuss heating and cooling systems, utilizing water, with their various components, maintenance, and testing, adjusting, and balancing (TAB).

Today's hydronic system can best be thought of as a heat transfer machine, large or small, where a heat transfer medium is used to carry heat to or from an area in accordance with the controls installed. Depending on the needs of the occupants, structure, and codes, the versatility of the hydronic system is limited only to the imagination of the person designing the system. A few basic fundamentals need to be learned before a person can do virtually anything desired in the heat transfer ability of a circulating water or hydronic system.

Whether the system is in a large multistory building project supplied by a central mechanical plant, or a small residence, the same basic fundamentals will still apply.

Purpose of Heating and Cooling Systems

The most basic objective of any heating and/or cooling system is to provide occupants with comfortable spaces so they may live, work, and perform well.

Normal body temperature is 98.6 °F. Food and other items we eat or take into our bodies is converted into energy in the form of heat that maintains the body's temperature, so this heat must be dissipated or taken away. With a body temperature of 98.6 °F, it is well noted that a comfort heating system does not warm us up. All it does is adjust inside conditions so the rate of body heat dissipation makes a person feel comfortable.

If heat is dissipated too fast, occupants feel cool; too slow, they feel hot and perspire. When air temperature and humidity are so high the body cannot rid itself of the heat fast enough, steps must be taken to cool and dry the air for comfort.

Bodies lose heat in three ways: radiation, evaporation, and convection. A warm body (human, steel, wood, plastic materials, etc.) loses heat to other surrounding bodies that are at lower temperatures. When standing next to a heated oven or out in the sun with no wind on a hot summer day, a person feels the heat radiated away from those hot objects until it hits the surface of their body and then absorbs it. This is radiation.

Evaporation mainly takes place through breathing but is rapidly increased as perspiration on the skin is introduced by overheating. The evaporation of this moisture on the skin causes a cooling effect because heat is taken away from the skin to change water into vapor.

Convection is the effect of moving air over a body and taking with it the heat at the surface of the body. †

Outdoor Conditions

Since each outdoor temperature is indicative of a different rate of heat loss, a heating system must be capable of operating at more than one rate to be effective and efficient. With a given indoor temperature, each outdoor temperature results in a different temperature which controls the rate of heat loss. Balancing the requirements of the various rates of heat loss calls for different rates of heat supply as the outdoor conditions may require.

Basic Hydronic Systems

Heating

A variety of heat sources and heat radiation are used for differing conditions of application. The source of heat may be from a boiler where the combustion of fuel in many forms provides the heat or from a converter wherein the heat of steam is transferred to the water. Both of these systems are shown in Figures E-1 and E-2.

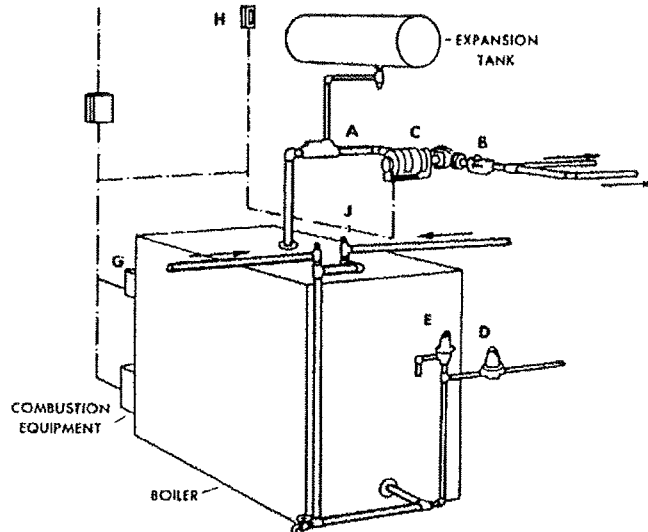

Figure E-1. Heat Supplied by Boiler.
 Illustration courtesy of Dunham-Bush, Inc.

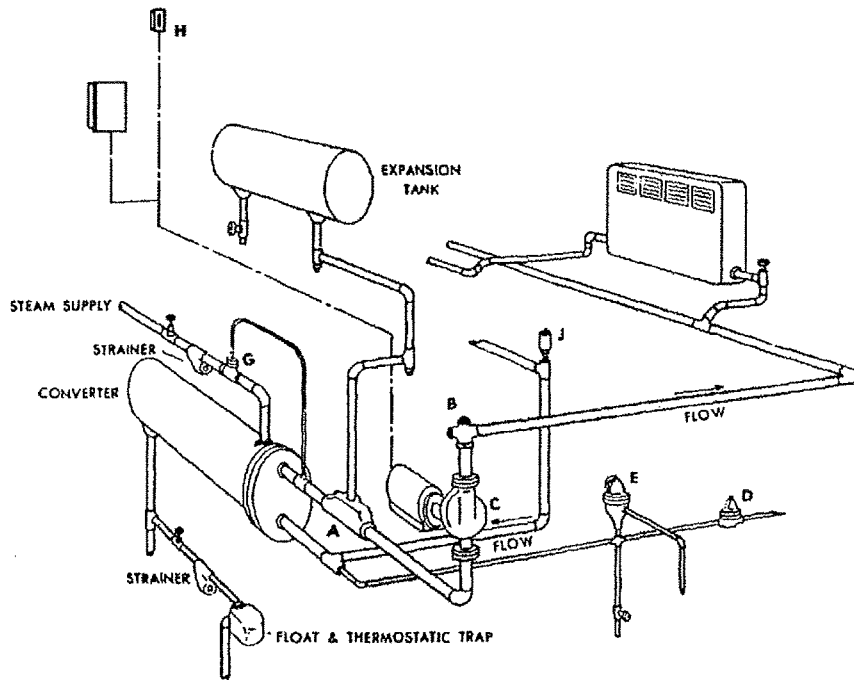

Figure E-2. Heat Supplied by Converter.
 Illustration courtesy of Dunham-Bush, Inc.

As described in Figures E-1 and E-2, the main water circuit is from the boiler or converter, through the air separator (A), and flow control valve (B), to the radiation, and back to the boiler or converter.

The flow control valve opens when the pump starts the water's movement and closes when it stops. The closed valve prevents gravity flow of water through the system.

Circulation of water at varying temperatures is controlled in one of several ways to maintain a proper room temperature level. Combustion and pump operations are automatically controlled while a room thermostat is used for control of room temperatures.

Pressure may be raised in hydronic systems to prevent water from steaming so higher temperatures may be obtained, making optional system temperatures obtainable. Where water is used for both heating and cooling, lower water temperatures and open expansion tanks are commonly used.

Cooling

For cooling, a system may be independent of a heating system or combined with one. Such a case of combination would be heating by baseboard or finned pipe units, and cooling by means of a central air-conditioning unit or individual combined heating and cooling units.

Individual fan coil units that operate for heating and cooling may be installed so the same piping is used for both. The arrangement that is more desirable depends on the requirements of the particular installation, including cost considerations. Figure E-3 shows an example of a hydronics heating and cooling system.

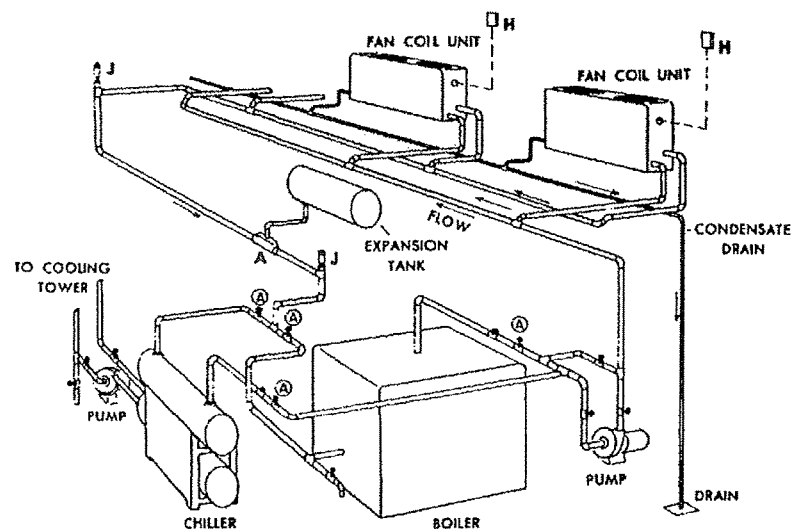

Figure E-3. Hydronics Heating and Cooling System With Change-over Valves.

Illustration courtesy of Dunham-Bush, Inc.

The change-over valves at the locations indicated by a circled "A" permit the system to change from heating to cooling.

2 Air Control in Hydronic Systems

One problem that continues to crop up frequently in hydronic systems, unless handled properly, is the quantity of air permitted to circulate or clog a system. Air control systems that are properly designed and installed can eliminate major problems, reduce maintenance, cut cost of operation, and perform efficiently. Effective air control will also prolong the life of the system and reduce unnecessary noise. Depending on the type of system used, the admission of air to the system will vary.

Once-Through and Recirculating Systems

A once-through system passes water through the equipment only once, then discharges it to a sewer. In a recirculating system, water is not discharged, but flows in a repeating circuit from the heat exchanger to the refrigeration equipment and back to the heat exchanger. Both of these types are further classified as open or closed systems.

Open and Closed Systems

An open system is one in which the water flows into a reservoir open to the atmosphere (i.e., cooling towers and air washers).

A closed system is one in which the flow of water is not exposed to the atmosphere at any point. These systems usually contain an expansion tank that is open to the atmosphere, but the water area exposed is insignificant.

Open systems are piping circuits pumped or gravity circulated. Closed systems are designed and installed as hermetically sealed systems. Some advantages of the closed or "sealed" system follow:

- When a system is closed, little if any make-up water is ever required.

- With no addition of fresh water, there can be no accumulation of oxygen and other corrosive agents. System life is extended indefinitely.
- Closed systems can be pressurized permitting elevated water temperature drops. Piping and operating costs can be reduced significantly.
- Closed systems with positive air control offers improved control, faster temperature response, and quieter system operation.

Whenever possible, closed hydronic systems are used for the reasons given above. Sometimes design conditions require the use of an open system. An example is the use of a water tower when the heat load to be removed from a space or spaces requires greater than 100 tons of refrigeration. The cooling tower allows water to dissipate heat to the atmosphere for these large cooling capacities, thus exposing water to the atmosphere also.

Although a system may be designed as a closed system, too often they end up as an open system unless all components are pressure-tight and leak-proof. Special consideration should be given to pump seals, manual air vents, and tight installations.

Mechanical seals. Mechanical seals are required for all closed system circulating pumps. A specific kind of pump seal, known as the "packing gland" type, requires constant water leakage to provide seal lubrication. This means fresh water must be constantly added to the system or, theoretically, the system will eventually run dry.

Because fresh water contains air and other corrosive agents, system life and operation will be seriously affected. Also, foreign particles of sand and dirt that are often found in fresh water supplies will enter and accumulate within the system. Therefore, water-tight mechanical pump seals should always be used on closed hydronic systems.

Manual air vents. Manual air vents should be used where initial venting of high points in the system is necessary to fill the system with water. Automatic air vents, if allowed to operate automatically after the system is placed into operation, are a source of system leakage. A given amount of air or gas space is required in every system to accommodate water expansion and pressurization.

The first step in providing adequate air control is to design a closed system that is actually closed. Not only must a system be designed as a closed system, but it must also be **installed** as a closed system. Proper installation techniques with adequate allowance for pipe expansion and contraction are necessary.

Unnecessary gauge glasses, particularly when installed in compression tanks, are common sources of air and water leaks. Packing materials in the glass assembly may dry out, and allow air leakage. Normally, gauge glasses on compression tanks serve very little purpose because tanks are often located in high and inaccessible locations. Furthermore, the visible indication of an air level in a tank does not always mean that a proper air cushion is present.

Air levels that vary at different times and in different systems are more apt to confuse than to help. Compression tanks, therefore, should be constructed with a minimum of openings, preferably with no openings located above the water line.

3 Components of Hydronic Systems

Warmed water heating and chilled water cooling systems are at their best levels of performance when the terminal equipment and piping circulation is positive and balanced, free of air, and the systems are under proper pressure.

The devices that perform or promote these functions are called "specialties" and include: air separators, air vents, flow valves, pressure relief valves, pressure reducing valves, radiator valves, balancing fittings, vent tees, and diverter fittings. Small capacity low head circulating pumps and small closed expansion tanks sometimes are also called specialties.

Because the principles of selecting these specialties for systems are a matter for the design engineer to specify, only a brief description of each will be given here.

Component Locations

The system shown in Figure E-4 indicates the location of the before-mentioned specialties.

Air Separator

Number 1 in Figure E-4 indicates an air separator. An air separator (Figure E-5) releases entrained air from the water before it reaches the piping system and radiation-convectors for fan-coil units. It consists of a baffled chamber. The baffle in it is positioned to create the required amount of turbulence and deflect the flow to cause air bubbles to rise and accumulate in the upper part of the separator. From there, it passes up and into the expansion tank to help maintain the air cushion. Air separators range in size from 1 to 4 in.

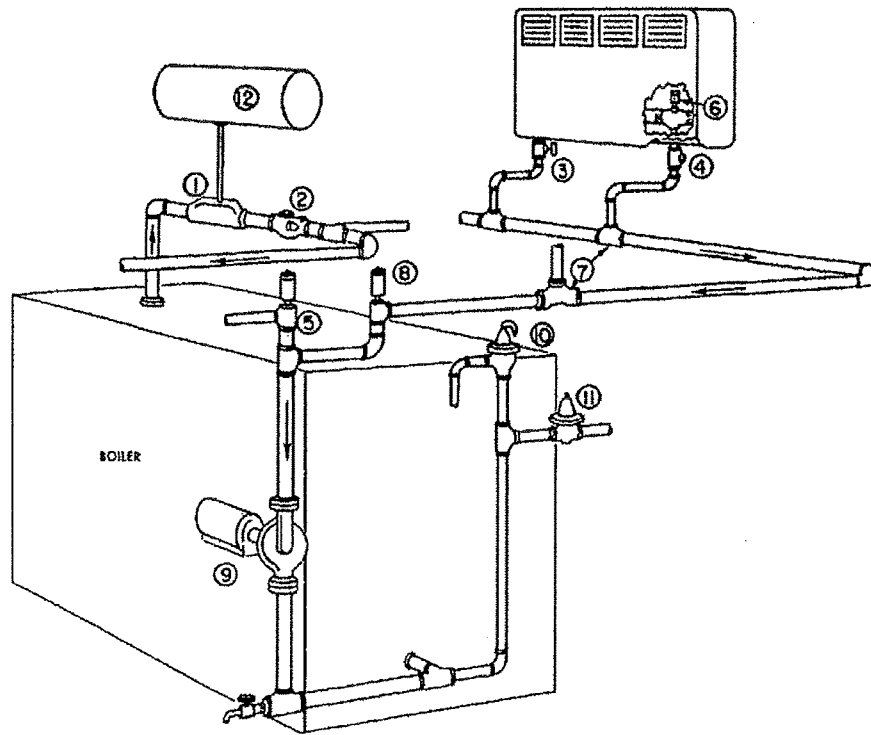

Figure E-4. Hot Water System Specialties.
Illustration courtesy of Dunham-Bush, Inc.

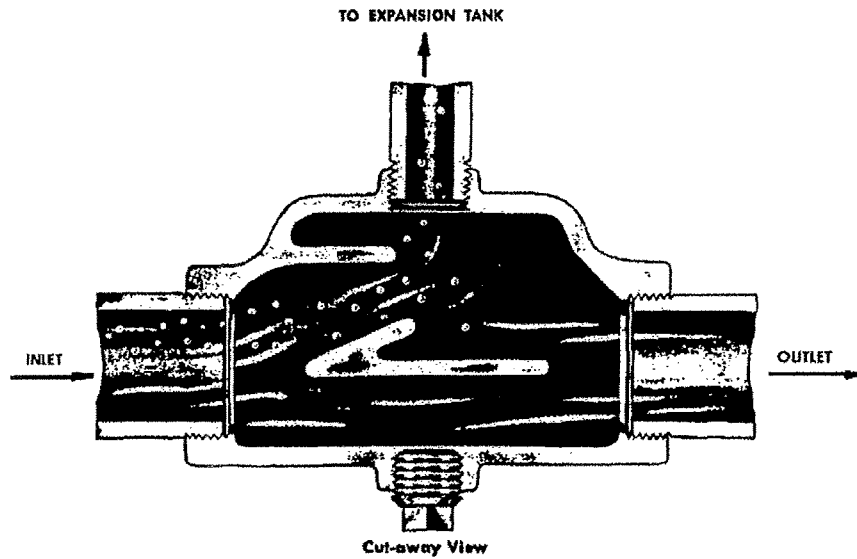

Figure E-5. Air Separator.
Illustration courtesy of Dunham-Bush, Inc.

Air separators should be installed horizontally in the supply main about 18 in. from the point where the main rises vertically from the boiler or converter as shown in Figure E-6.

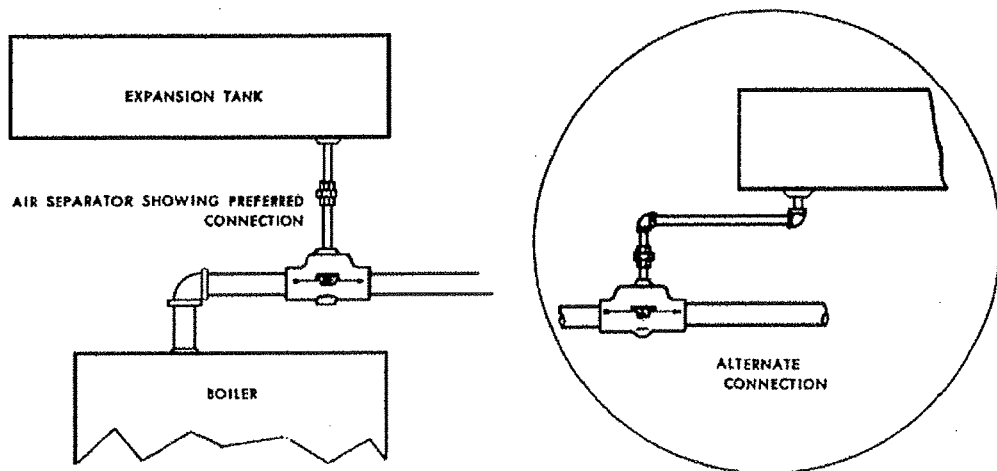

Figure E-6. Installation of Air Separator.
Illustration courtesy of Dunham-Bush, Inc.

Flow Control Valve

Number 2 in Figure E-4 indicates the proper location of the flow control valve. Flow control valves control the direction of water flow and prevent circulation of hot boiler water when heat is not needed, as when the circulating pump has been stopped by its control. This permits the boiler water to be used at temperatures high enough to heat domestic water in winter and summer since the valves prevent circulation by gravity. These valves are made in two patterns, horizontal (straightway) and universal pattern as in Figure E-7.

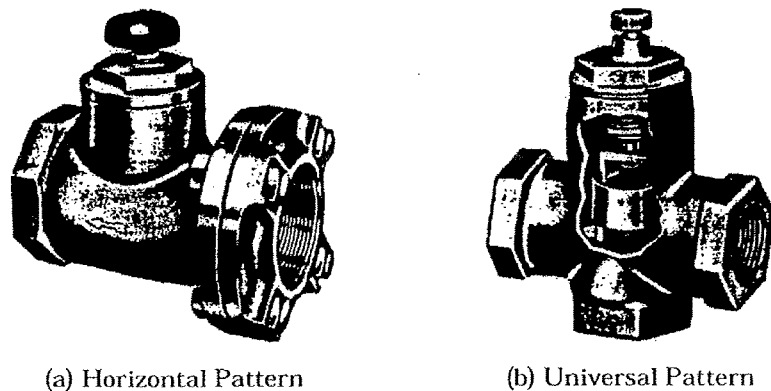
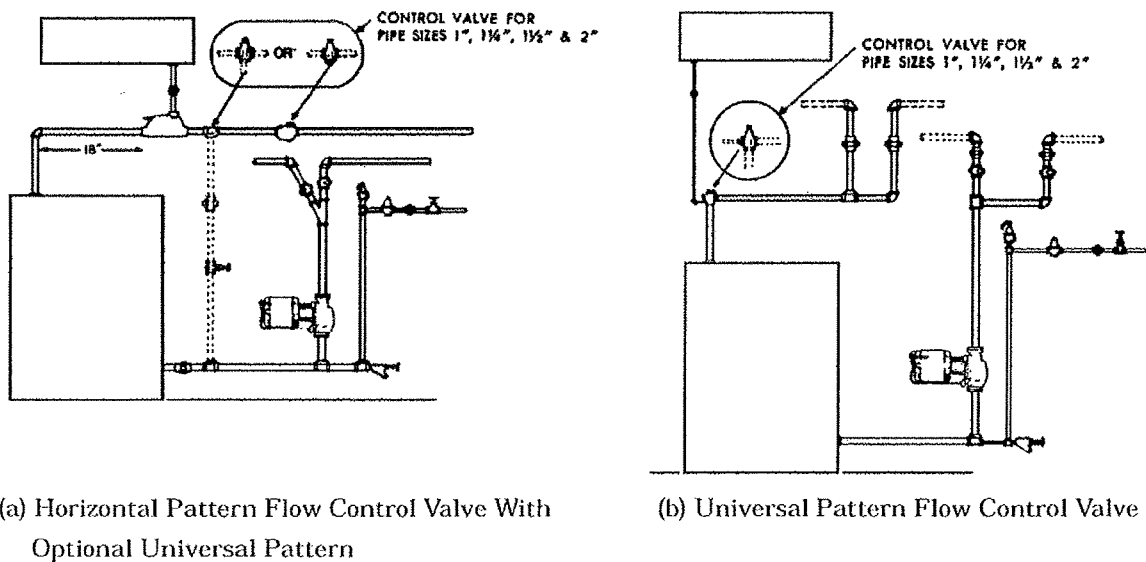

Figure E-7. Flow Control Valves.
Illustration courtesy of Dunham-Bush, Inc.

The horizontal pattern valves are manufactured in 2-, 2-1/2-, and 3-in. sizes while the universal pattern used for pipe sizes 1 to 2 in. inclusive may be installed for either angle or straightway application. The flow control valve should be installed in the main beyond the air separator, before any branches are taken off (see Figure E-8).



(a) Horizontal Pattern Flow Control Valve With Optional Universal Pattern

(b) Universal Pattern Flow Control Valve

Figure E-8. Flow Control Valves.

Illustration courtesy of Dunham-Bush, Inc.

When the pump is running, the disc on top raises to open the valve; when the circulator stops, the disc closes tight to prevent gravity flow. The external adjustment arm may be positioned to "open," "normal," or "closed" settings. For regular winter or summer operations, it is set at "normal." Every zone should include a flow control valve.

Circulator Valve

Number 3 of Figure E-4 indicates the location of a circulator valve. Terminal equipment such as convectors and fan-coil units should be valved individually. When applied to these terminal units, circulator valves (Figure E-9) give occupants instantaneous on-or-off control of water flow. Large self-cleaning waterways reduce the water resistance and circulator load, and the T-type handles indicate the inner valve position that opens and closes fully in 1/4 turn. These valves may be set for partial flow.

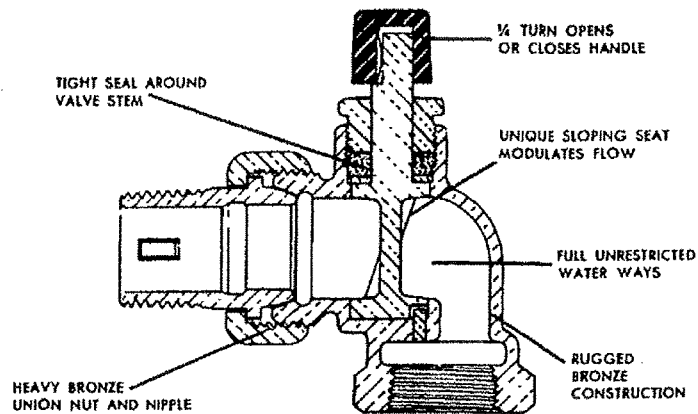

Figure E-9. Circulator Valve.

Illustration courtesy of Dunham-Bush, Inc.

Balancing Elbow and Balancing Fitting

Number 4 of Figure E-4 indicates the location of a balancing elbow and a balancing fitting. The flow balancing that cannot be handled by piping design must be handled by other equipment. Balancing elbows and fittings permit balancing the water to individual terminal equipment.

Once properly adjusted, each radiator or other terminal equipment receives the water flow needed for even heat. Balancing fittings for floor panels should be conveniently accessible for adjustment after the concrete floor has been poured.

Vent Tee

Number 5 of Figure E-4 indicates the location of a vent tee. Vent tees are a convenience for arranging for the application of air vents. They save space for base board and perimeter type convection radiation. A 1/2-in. tapped opening eliminates the need for bushing or drilling and tapping.

Expansion Type Air Vent

Number 6 of Figure E-4 indicates the location of an expansion type air vent. Air vents that release the air automatically promote effectiveness of terminal equipment. The type shown in Figure E-10 operates on the hygroscopic principle that allows the least amount of system leakage.

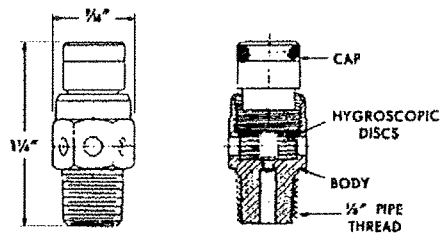

Figure E-10. Expansion Type Air Vent.

Illustration courtesy of Dunham-Bush, Inc.

Composition discs that become wet and expand, seal venting points when the system is filled. Entrapped air dries and contracts the discs, opening the venting ports. The vents require no adjustment.

The vents may be manually operated by turning the cap counter-clockwise 3/4 turn to permit rapid air removal when the system is first filled. Each piece of terminal equipment, as well as high points of mains and branches where air might collect, should be equipped with a vent.

Vents should not be installed inverted; however, they do operate satisfactorily in the vertical upright or horizontal position. Some venting applications are shown in Figure E-11.

Diverter Fitting

Number 7 of Figure E-4 indicates the location of a flow diverter fitting. Diverter fittings were developed to reduce the labor and inconvenience of using complicated connections at a single main radiator. These fittings proportion the energy in the flowing stream to provide needed energy by imposing resistance to flow in the main.

They are needed on all systems and zones piped for a single pipe circuit, except where the radiation itself serves as a portion of the main—as in baseboard systems.

Float Type Vent

Number 8 of Figure E-4 indicates the location of the float type vent. Some points along the piping system and certain types of radiation require prompt, rapid venting. The high points of downfeed systems and the ends of mains of larger systems are locations where proportionately large venting capacity is needed. Figure E-12 illustrates an example of a float type vent.

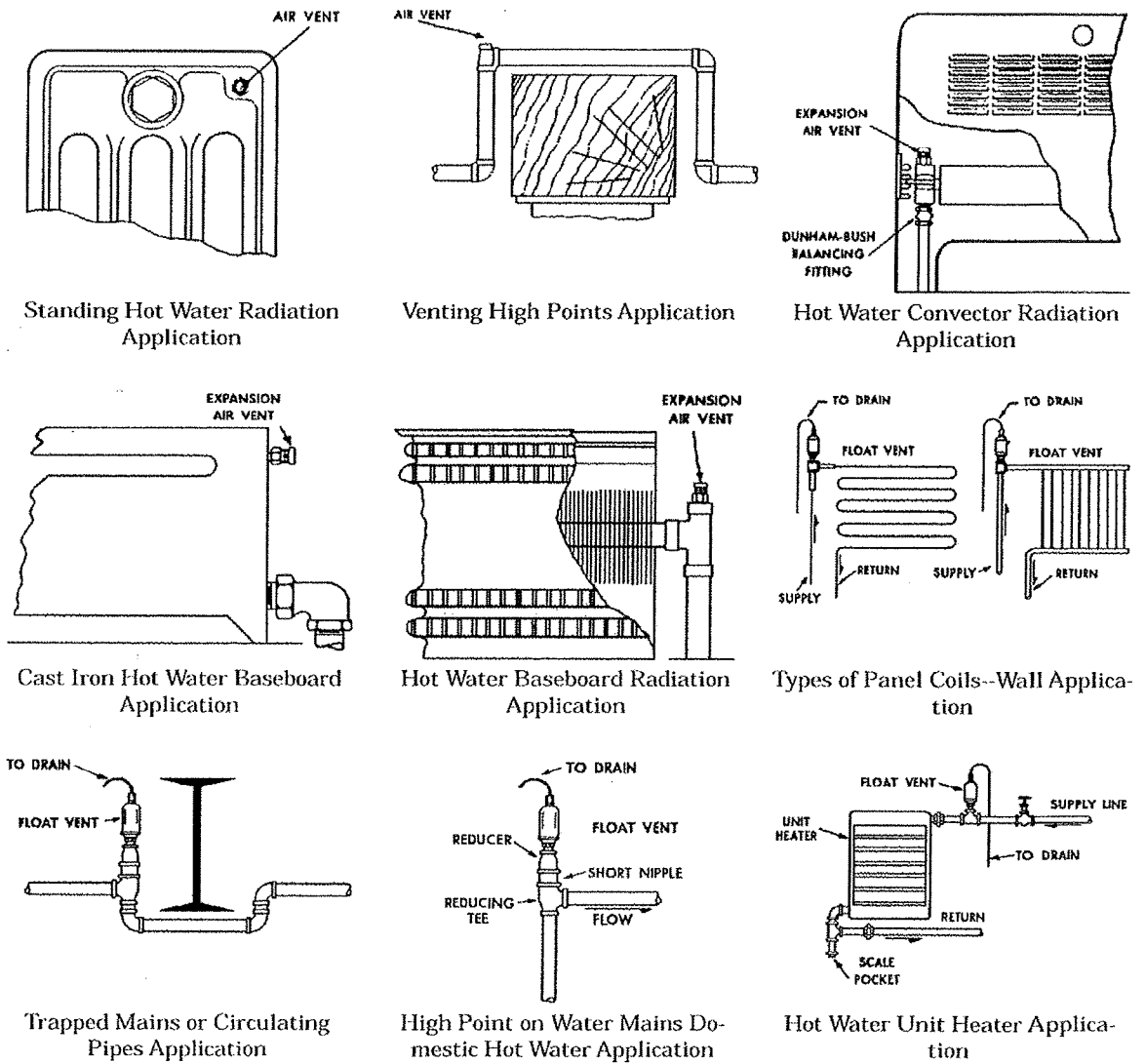

Figure E-11. Typical Air Vent Installations.

Illustration courtesy of Dunham-Bush, Inc.

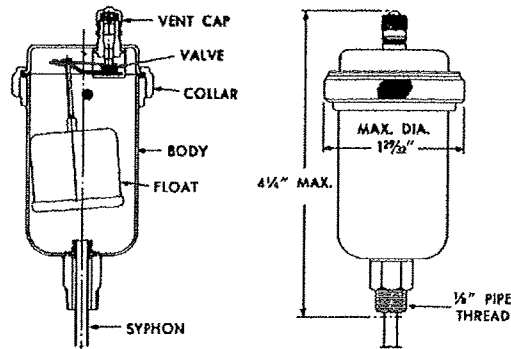

Figure E-12. Float Type Vent.

Illustration courtesy of Dunham-Bush, Inc.

Float type vents operate continuously and automatically, and serve both warm and chilled water lines. Air vents constructed to eliminate water logging, as is the case with the float type vents shown in Figure E-12, are preferable.

They should be installed with drain tubes arranged to discharge to a suitable place whenever their location presents the possibility of damage to the construction or furnishings, if the vent should spurt water.

Hydronic Circulators

Number 9 of Figure E-4 shows hydronic circulators. Please refer to Section 6 (of this appendix) on hydronic pumps and circulators.

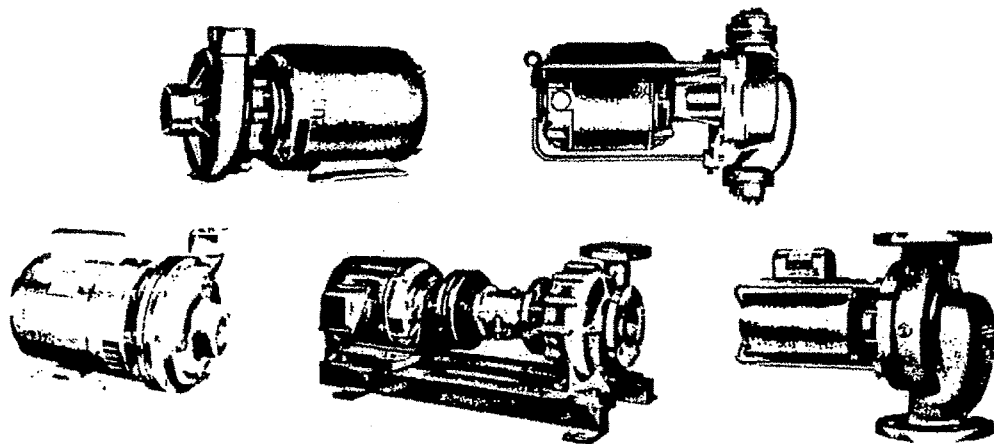

Figure E-13. Circulators.

Illustration courtesy of Dunham-Bush, Inc.

Pressure Relief Valve

Number 10 of Figure E-4 indicates the location of a pressure relief valve. Low-pressure systems are usually limited to 30 psig pressure. Relief valves (Figure E-14) are needed with systems using closed expansion tanks. Some relief valves are equipped with a diaphragm arrangement that transmits more power during opening of the valve; a spring chamber seals an adjusting spring against corrosive action of discharge water. Systems larger than 250,000 Btu/h may require two valves.

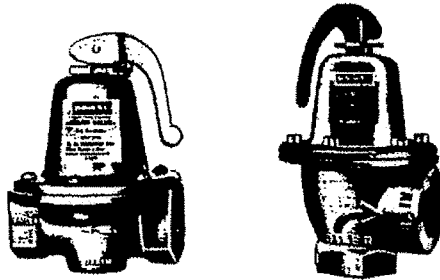

Figure E-14. Pressure Relief Valves.
Illustration courtesy of Dunham-Bush, Inc.

Pressure Reducing Valve

Number 11 of Figure E-4 indicates the location of a pressure reducing valve. Pressure reducing valves are needed to keep systems with closed expansion tanks under proper pressure and automatically filled. The valves shown in Figure E-15 maintain a minimum water pressure of 12 psig on the system. Any drop of pressure below 12 psig causes the valve to open and feed water into the system.

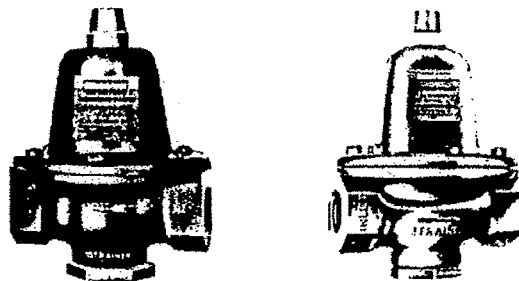

Figure E-15. Pressure Reducing Valves.
Illustration courtesy of Dunham-Bush, Inc.

A common practice for pressure reducing valves and relief valves is to install them in tandem. For this type of application, dual units, as illustrated in Figure E-16, are convenient.

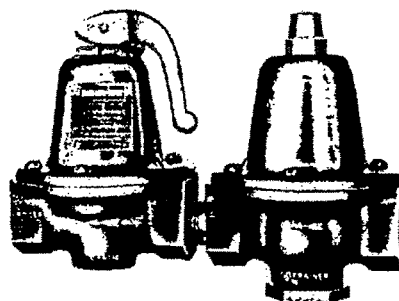
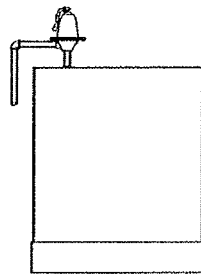
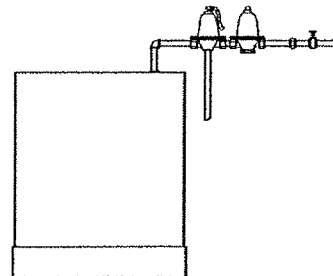

Figure E-16. Dual Unit Valves.
Illustration courtesy of Dunham-Bush, Inc.

Pressure reducing valves and dual unit valves are installed as indicated in Figure E-17.



(a) Relief Valve



(b) Dual Unit Relief and Reducing Valve

Figure E-17. Relief Valves.

Illustration courtesy of Dunham-Bush, Inc.

Expansion Tank

Number 12 as illustrated in Figure E-4 indicates the location of an expansion tank.

4 Piping Methods

An important contribution to satisfactory performance is the method of piping one selects in the design process. Some concerns in the selection of the type or method chosen are arrangement, construction, occupancy and size of the building, and space available for the piping. Low first cost is important, but more importantly, the piping must promote low overall system cost with economy, reliability, and ease of operation. With each piping system comes inherent flow characteristics and corresponding adaptability for particular purposes.

What each of these factors can provide for satisfactory system performance is the basis for selecting the piping system to be used. Sometimes the necessity for keeping first cost at a minimum determines whether the piping shall be arranged so that it tends to be "self-balancing" or whether balancing devices will be used periodically. The deciding criterion is the cost of the additional material needed to pipe the system so it tends to be "self-balancing" compared to the cost of balancing after installing it. In small systems, balancing the flow after installation is usually only a minor problem, so the savings in material makes for the lowest installed cost.

Hydronic distribution supply and return mains are often located at corridor ceilings, above hung ceilings, wall-hung along a perimeter wall, and in pipe trenches, crawl spaces, or basements. System piping does not need to be run at a definite level or pitch.

Water System Piping Classification

Water system piping can be divided into two classifications: circuits for small systems and main distribution piping.

Circuits for Small Systems

These are pipe circuits suitable for complete small systems or as terminal or branch circuits on large systems.

- Series loop
- One-pipe
- Two-pipe reverse-return
- Two-pipe direct-return.

Main Distribution Piping

Main distribution piping is used to convey water to and from the terminal units or circuits in large system.

- Two-pipe direct-return
- Two-pipe reverse-return
- Three-pipe
- Four-pipe.

Pipe Circuit Types

Series Loop System

A series loop system is a continuous length of pipe or tube from a boiler or chiller supply connection back to the boiler or chiller return connection. Terminal units are part of the loop.

One or many series loops may be used in a complete system. For example, a multistory building may have a series loop on each floor with supply and return to the same source. While giving off heat, the water temperature drops continually as each room terminal unit transfers heat to the air. The amount the temperature drops will depend on the water flow rate and unit output. Comfort cannot be maintained in separate spaces heated with a single series loop if water flow rate is varied. This is due to the following simple facts: the average water temperature shifts down progressively from the first to last unit in series, and unit output gradually lowers from first to last on the loop. Figure E-18 is an example of a series loop system with baseboard forced-circulation warm water installation.

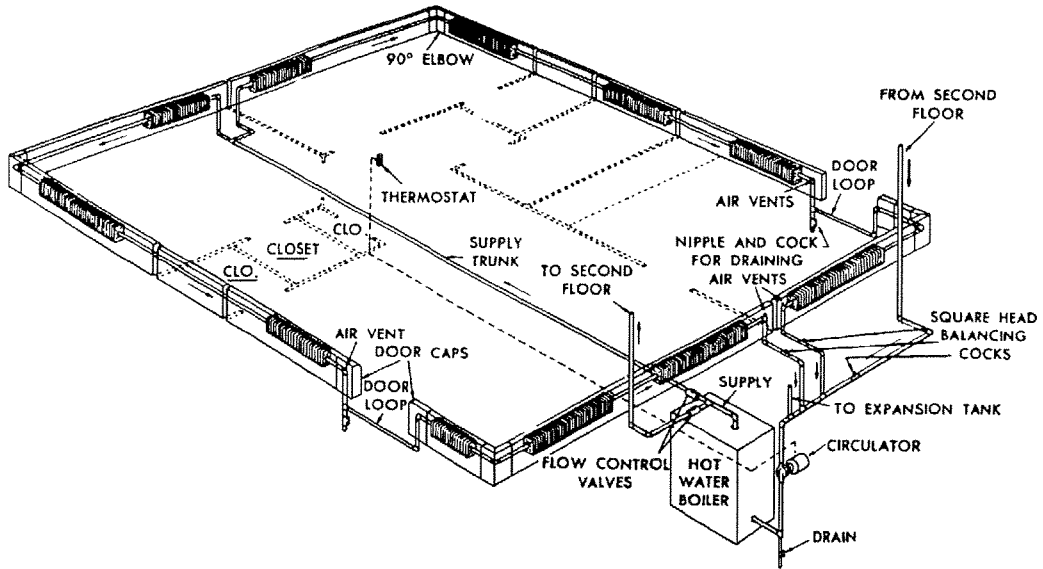

Figure E-18. Series Loop System.

Illustration courtesy of Dunham-Bush, Inc.

One-Pipe Systems

One-pipe circuits make use of a single loop as a supply and return main. For each terminal unit, a supply and a return tee are installed on the same main. One of the tees is a diverting tee that creates a pressure drop in the main flow to divert a portion of the main flow to the unit.

Unlike series loop systems, one-pipe circuits allow manual or automatic control of flow to individually connected heating units. An on-off rather than flow modulation control is recommended because of the relatively low pressure and flow diverted. A one-pipe system is shown in Figure E-19.

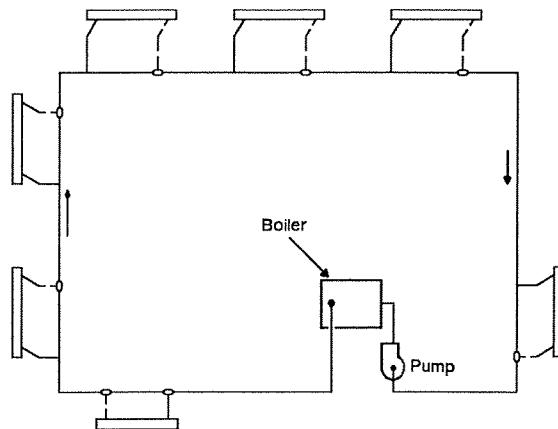

Figure E-19. One-Pipe System.

Reproduced with permission from the National Environmental Balancing Bureau, December 1996.

Two-Pipe Systems

Two-pipe circuits may be direct-return or reverse-return. In the direct-return, the return main flow direction is opposite supply main flow; return water from each unit takes the shortest path back to the boiler. This is indicated in Figure E-20.

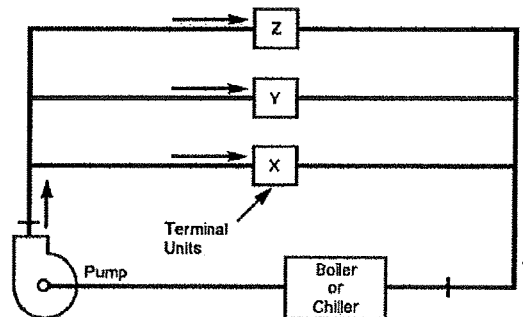

Figure E-20. Two-Pipe Direct-Return.

Reproduced with permission from the National Environmental Balancing Bureau, December 1996.

In the reverse-return, the return main flow is in the same direction as supply flow; after the last unit is fed, the return main returns all water to the boiler (Figure E-21).

The direct-return system requires less return main piping, but circuit valves are usually required on units or subcircuits. Because water flow distance to and from the boiler is nearly the same through any unit on a reverse-return system, balancing valves require less adjusting. Pumping costs are likely to be higher in the direct-return system because of the added balancing fitting drops at the same flow rates.

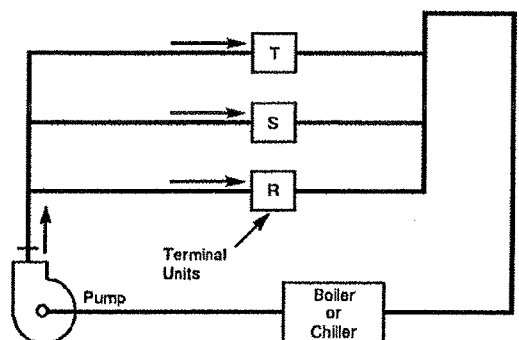

Figure E-21. Two-Pipe Reverse-Return.

Reproduced with permission from the National Environmental Balancing Bureau, December 1996.

Three-Pipe Systems

A three-pipe system (Figure E-22) is usually used with an induction system and will satisfy the variation in load by providing independent sources of heating and cooling to the room unit in the form of constant temperature primary or secondary chilled and hot water. If used with an induction unit, it contains a single secondary water coil.

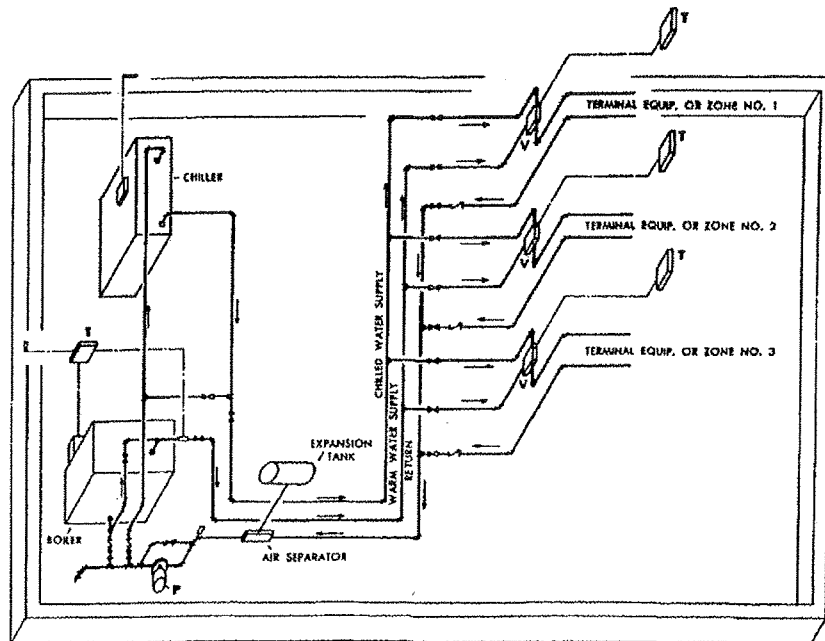

Figure E-22. Three-Pipe System.

Illustration courtesy of Dunham-Bush, Inc.

A three-way valve at the inlet of the coil admits the water from the hot or cold water supply as required. The water leaving the coil is carried in a common pipe to either the secondary cooling or heating equipment.

Four-Pipe Systems

Systems for induction and radiant panel or fan-coil systems derive the name four-pipe systems because of the four pipes to each terminal unit. The four pipes consist of a cold water supply, a cold water return, a warm water supply, and a warm water return.

The four-pipe system (Figure E-23) satisfies variations in cooling and heating to the induction units using temperature primary air, secondary chilled water, and

secondary hot water. Terminal units are provided with two independent secondary water coils; one served by hot water and the other by cold water.

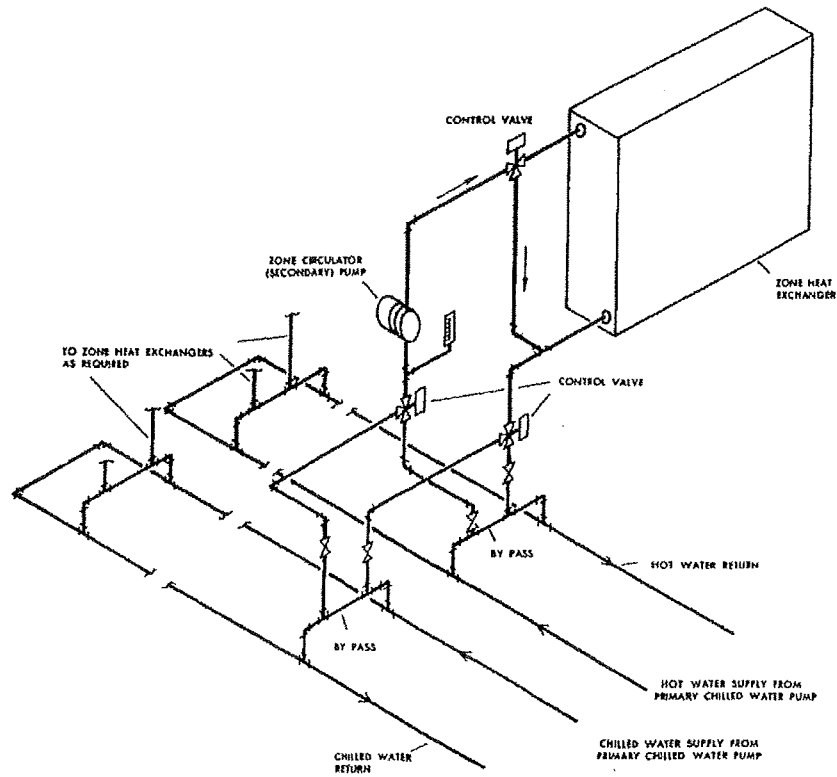

Figure E-23. Four-Pipe System.

Illustration courtesy of Dunham-Bush, Inc.

5 Terminal Equipment

The equipment used in conditioning space air in hydronic comfort cooling, air-conditioning systems, and space heating equipment is referred to as terminal equipment. Space heating equipment, however, is more frequently referred to as "radiation."

Terminal equipment used for cooling includes unit room coolers, unit space coolers, and air-handling units.

Terminal equipment used in heating includes converters, storage water heaters, heat exchange equipment at which supply pipes terminate, free-standing radiation, convectors, finned tube radiation, unit heaters, unit ventilators, and central fan heaters.

Cooling Equipment

Conditioning air, at a minimum, would include simultaneous control of temperature, humidity, motion, and cleanliness of air. Satisfactory conditioning of air depends not only on equipment selection but also on applying it so the following conditions are met:

- Uniform air temperatures each space requires.
- Comfortable humidity or wet bulb temperature required.
- Continuous, mild, uniform air motion within the occupied level; no drafts of contrasting air movement, such as a variable speed fan may cause.
- Proper control of mean radiant temperature.
- Freedom from odors by regulating air changes per hour.
- Air cleanliness prescribed by code or occupancy.

- Noise criterion.
- Maintenance and operating procedures.

Unit Room Coolers

Unit room coolers are sometimes referred to as fan-coil units and are capable of cooling, heating, or both. This type of conditioning equipment uses chilled water as its cooling medium and is usually located a good distance from the chiller. Sometimes it is referred to as "remote conditioning equipment." Several types of fan-coil units are used today.

Vertical units.

- Cabinet: This type is located within the space cooled (Figure E-24).
- Basic: These are used for concealment within the building structure or in a cabinet and enclosure housing the piping or finned radiation (Figure E-25).
- Recessed: Made for recessing in the building's wall (Figure E-26).

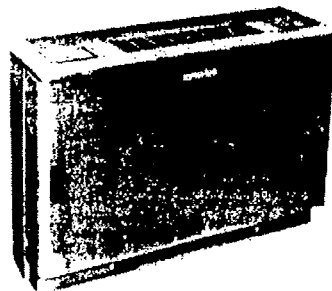

Figure E-24. Cabinet Type Fan-Coil Unit.

Illustration courtesy of Dunham-Bush, Inc.

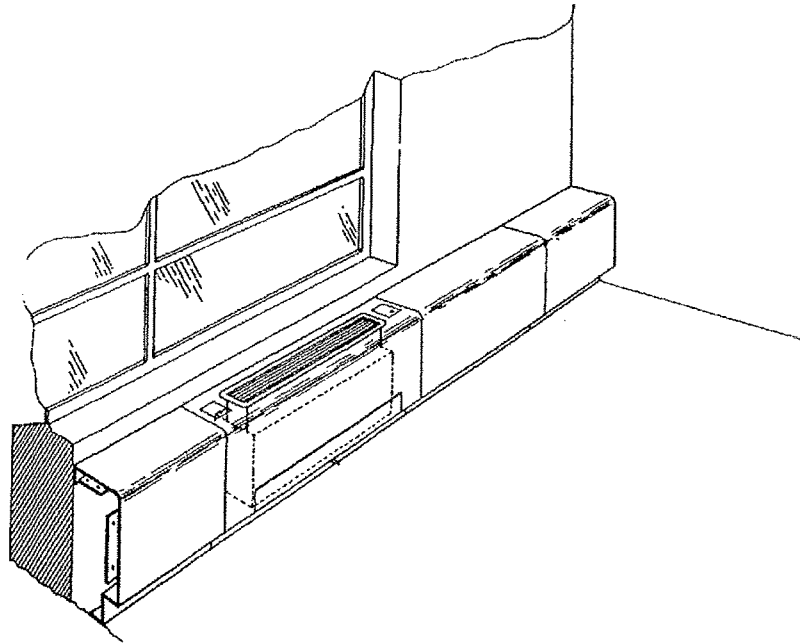

Figure E-25. Basic Type Fan-Coil Unit.

Illustration courtesy of Dunham-Bush, Inc.

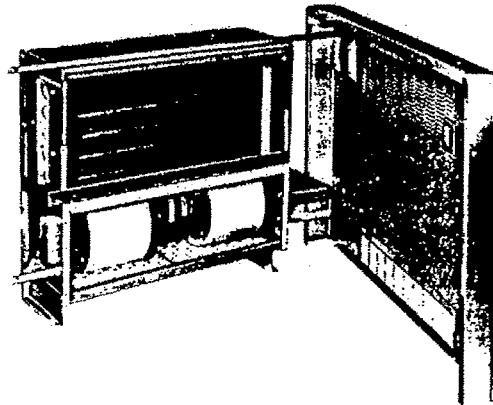

Figure E-26. Recessed Type Fan-Coil Unit.

Illustration courtesy of Dunham-Bush, Inc.

To better visualize the components of the cabinet, recessed, and basic fan-coil unit, see Figure E-27.

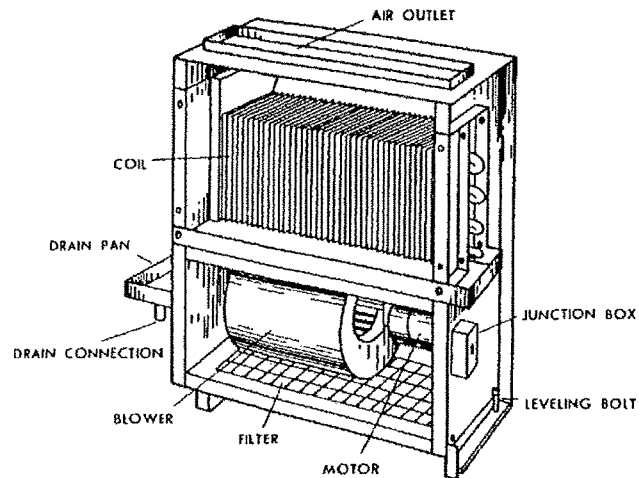

Figure E-27. Components of a Fan-Coil Unit.

Illustration courtesy of Dunham-Bush, Inc.

Horizontal units.

Cabinet: These units are hung from the ceiling of the conditioned space. An insulated case encloses the blower overhung on the motor shaft, drain pan with connection, and space for the control and valve equipment. Figure E-28 illustrates this concept.

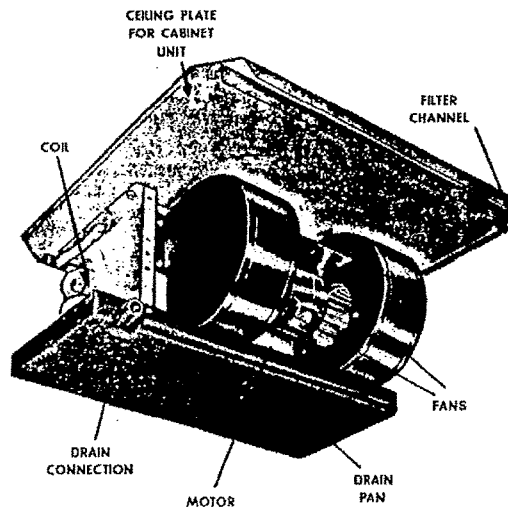

Figure E-28. Cabinet Type Horizontal Unit.

Illustration courtesy of Dunham-Bush, Inc.

Basic: The basic unit is mounted in the ceiling of the space. The case is formed by the enclosed building construction, but the construction is otherwise the same as for the cabinet unit. Figure E-29 shows a sample ceiling construction and unit.

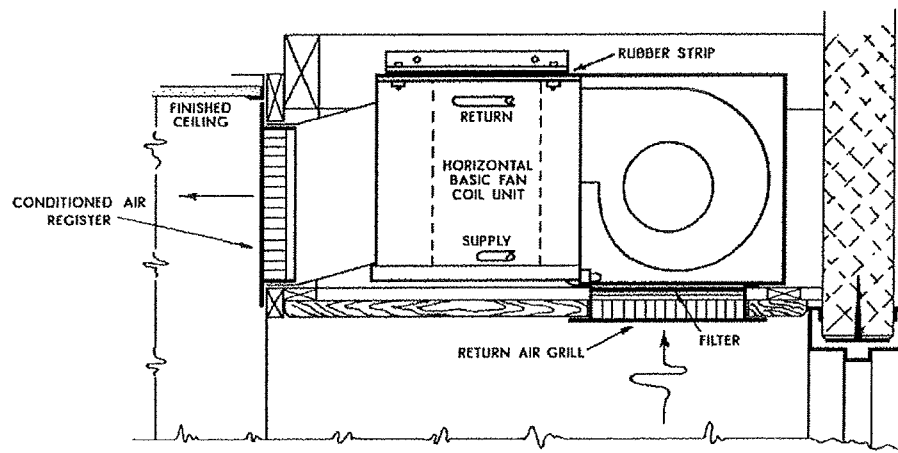

Figure E-29. Basic Horizontal Fan-Coil Unit.

Illustration courtesy of Dunham-Bush, Inc.

Unit Space Coolers

Unit space coolers are the same as unit room coolers, but differ in their capacity. Because of this difference, their construction is slightly different. They use a single fan, double width, and double inlet for all sizes. They are capable of operating against a higher static pressure than room units, including the pressure drop within the unit through filter and coil. The throw is greater for a free outlet discharge than for the horizontal units. Ventilation air may be supplied through-the-wall by use of mixing boxes that are built on the job by the installer.

Air-Handling Units

Air-handling units are usually assembled in the factory and are much the same as a central fan or conditioning system. Figure E-30 shows several types of air handling units.

An air-handling unit may be used to lift a load from an interior space that has no heat loss but only gains from equipment, people, and lighting. It may also be used where the air from separate rooms may not be mixed.

These units are typically used for cooling, heating, or both, wherever large capacities and correspondingly long throws are required. They are also used when specific air conditions are to be provided.

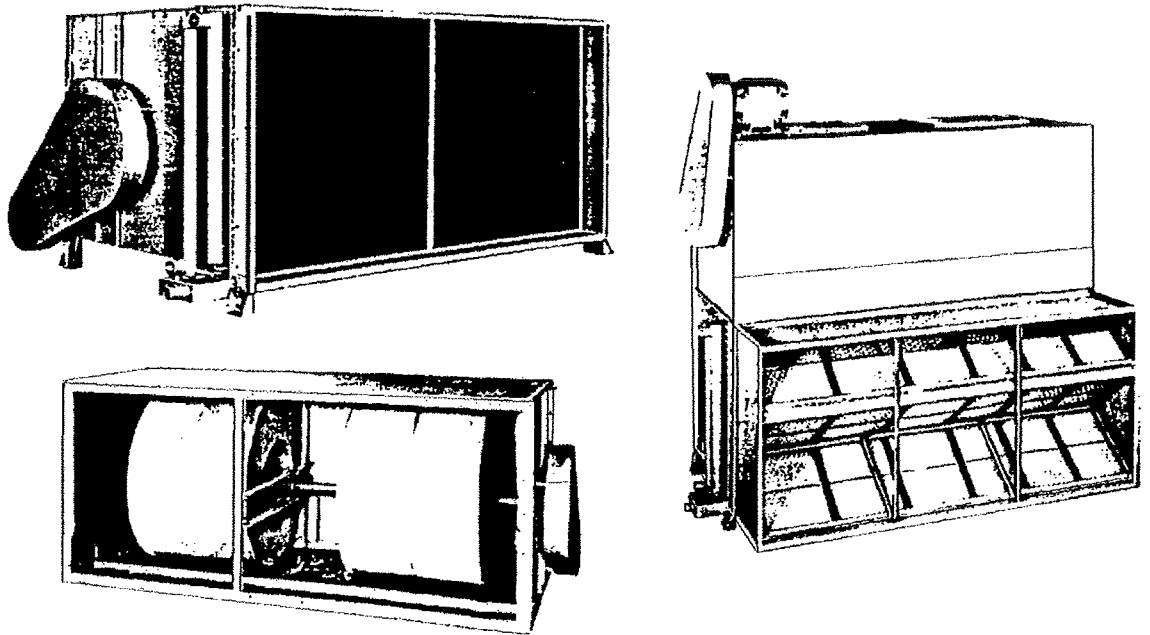

Figure E-30. Air-Handling Units.
Illustration courtesy of Dunham-Bush, Inc.

Heating Equipment

Some general guides for applying terminal equipment for heating are as follows:

- Locate enough radiation in bays and alcoves to avoid pockets of cold air in these particular areas.
- In long rooms, space the radiation at proportionate distances from each other so the radiation will spread uniformly through the occupancy.
- Enough extra radiation should be supplied to rooms (such as kitchens, bathrooms, etc.) that have exhaust fans to compensate for heat being lost through the exhaust.
- Radiation should be located under windows and along perimeter walls of the building. These locations have down drafts of cold air which need to be counteracted.
- On landings in a stairway, radiation will counter down drafts that occur in these areas.

Perimeter Radiation

When exterior walls are constructed in such a way that cold surfaces can result on the inside of the wall, uniform temperatures are not attainable unless the radiation extends over the exposed wall area or under areas such as glass. For this purpose, finned pipe radiation is used.

Shielding, cleanliness, and appearance are important factors in a unit radiating heat. If dirt and lint particles cover the finned parts of the tube, the heat transfer will be reduced significantly.

Baseboard radiation. The baseboard is a form of convection equipment using finned tubing. The tubing, fins, and shield are placed where the floorboard or baseboard is located around the perimeter of the room. The tubing is usually steel with steel fins or copper with aluminum fins. A finned tube baseboard is shown in Figure E-31.

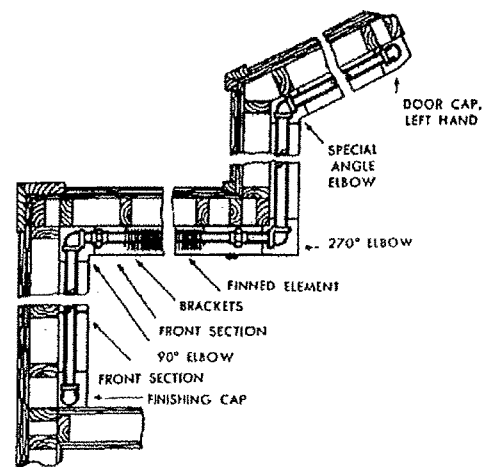

Figure E-31. Finned Tube Baseboard.

Illustration courtesy of Dunham-Bush, Inc.

Systems using finned type radiation and baseboard should be zoned properly. If not zone controlled, piping circuits should be divided so that each supplies portions of the building subjected to the same variable conditions, hours of use, sun, prevailing wind, and so forth.

The three types of standard baseboards—semi-recessed, flush (1-in. tube with 2-3/4-in. x 4-in. fin), and flush (3/4-in. tube with 2-3/4-in. square fin)—are illustrated in Figure E-32.

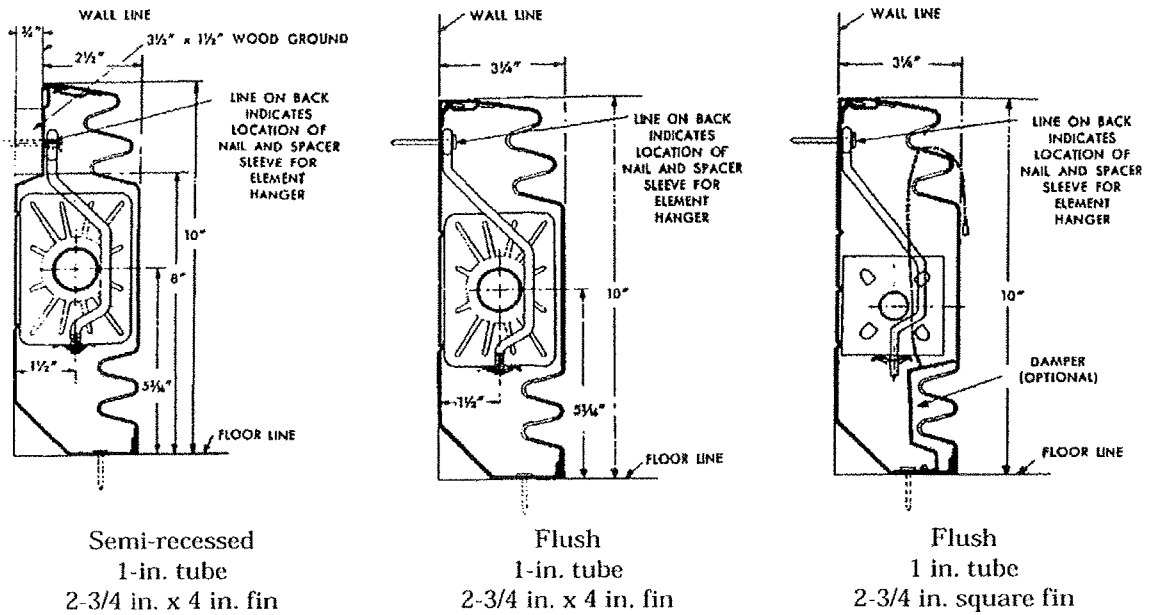

Figure E-32. Standard Baseboard Types.

Illustration courtesy of Dunham-Bush, Inc.

Along-the-wall radiation. The difference between baseboard and along-the-wall radiation is that higher heating capacities are required for industrial, institutional, and commercial buildings. The along-the-wall type radiation has higher heating capacities than finned tube radiation; therefore, larger heating loads may be handled with low height enclosures. An example of along-the-wall radiation is shown in Figure E-33.

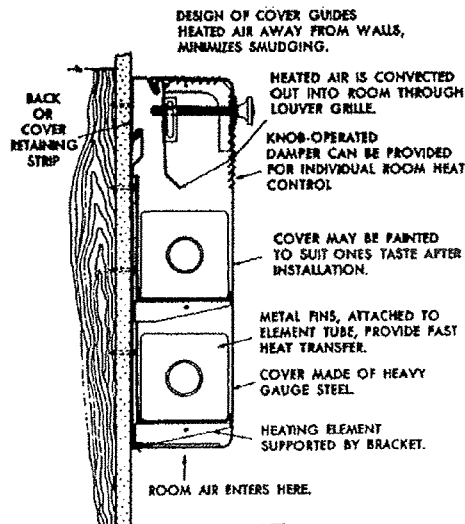

Figure E-33. Along-the-Wall Radiation.

Illustration courtesy of Dunham-Bush, Inc.

Heating Coils

Heat exchangers used for heating air are called heating coils. Heating coils can be used on gravity and mechanically circulated applications. Gravity convection is experienced by the natural flow of hot air rising and cold air falling, while forced convection includes the use of a fan to circulate air.

Coils are used as a primary source of heat for warming the air. They may be located in branch ducts. In this case, they are called booster coil heaters. Coils may also be used to reheat chilled air for humidity control.

Blower Unit Heaters

Like other unit heaters, blower units are fan and heat exchanger coil assemblies in properly braced casings. Blower units are characterized by use of centrifugal fans, which are capable of handling large quantities of air against substantial pressures.

When they are used to heat and circulate air only, they are referred to as unit heaters. The unit may also be equipped to clean or temper the air by using filters or face-and-bypass dampers.

Blower unit heaters (Figure E-34) can be built as vertical or horizontal units. These assemblies are often located a distance from the spaces to be occupied, and supply air is transported to the rooms by ducts.

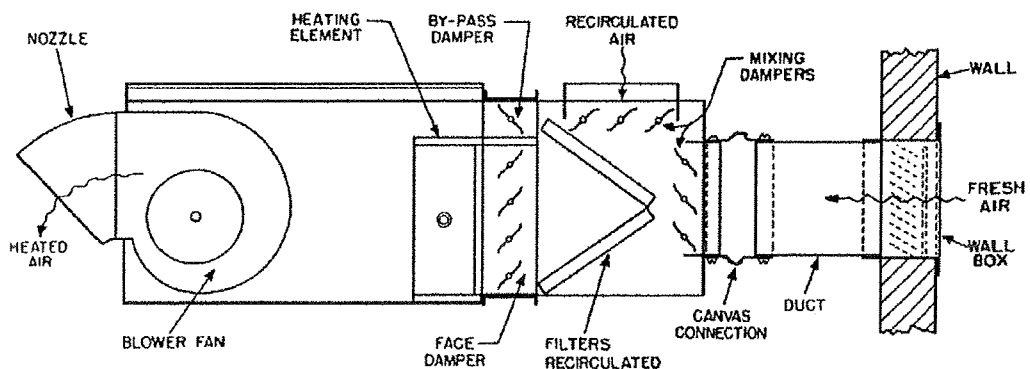

Figure E-34. Blower Unit Heater.

Illustration courtesy of Dunham-Bush, Inc.

Convectors

Convector type radiation supplies heat by slow air movement and mild radiant effects for proper comfort. Without the intense radiant heat put off by radiators and bare tubing, occupants may be placed close to the convector and still maintain comfort.

Some units may be equipped with dampers to regulate the air flow. These are comprised of two major parts, the heating element and the enclosure. The enclosures are usually the cabinet or along-the-wall type.

Convector elements are lightweight and do not resist or absorb expansion strains that are transmitted from the riser through branch pipes. Therefore, the branch pipe should have at least three elbows.

Branch connections from risers to convectors should be arranged to maintain the proper pitch when the piping is heated and expanded. The supply connections to the heating element may be made at the bottom, top, or end of the inlet header. The return connections are made at the bottom of the opposite header. Figure E-35 shows a floor cabinet convector.

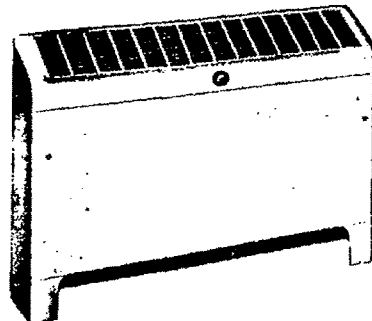

Figure E-35. Floor cabinet convector.

Illustration courtesy of Dunham-Bush, Inc.

Forced Convection Space Heating Equipment

Unit heaters are usually placed in or adjacent to the space heated to force air into the occupied space. Large-sized unit heaters are used with or without distribution ducts. The several types of unit heaters can be classified as blower fan and propeller fan types. The propeller type may be categorized as horizontal discharge and vertical discharge units.

The units are comprised of a heat exchanger and a fan enclosed in a casing arranged to be suspended from the building construction. Figure E-36 shows vertical and horizontal discharge units.

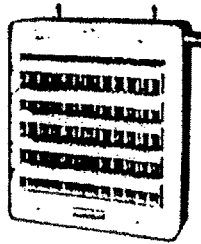

Horizontal Discharge



Vertical Discharge

Figure E-36. Horizontal and Vertical Discharge Units.

Illustration courtesy of Dunham-Bush, Inc.

6 Hydronic Pumps

Centrifugal pumps are used to circulate the water in heating and cooling systems. These pumps are well adapted to hydronic systems because they are simple, compact, quiet, easy to maintain, and efficient for delivering large quantities of water against the forces encountered. Some pump applications include:

- Condenser water circuits to cooling towers and water source heat pumps
- Condensate return
- Boiler feed
- Recirculating hot water in heating systems and chilled water systems
- Circulating water to conditioning terminal units.

Pump Types

Centrifugal pumps used for heating and air conditioning may be defined by the type of impeller, number of impellers, type of casing, method of connection to driver, and mounting position. In these pumps, two types of impellers are used: single suction and double suction. A single-suction impeller has one suction or intake, while the double-suction impeller has two suctions or intakes.

Even though most centrifugal pumps used in heating and air conditioning are single suction, the significant example of a double-suction impeller is the single stage, horizontal split-case pump. Pumps with multiple impellers are called multistage pumps. Figure E-37 shows a centrifugal pump.

Like impellers, there are two types of casings for these pumps: volute and diffuser. The volute types include all pumps that collect water from the impeller and discharge it perpendicular to the pump shaft.

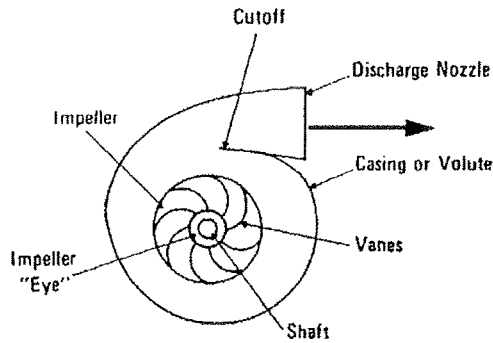

Figure E-37. Centrifugal Pump Cross-Section.

Reproduced with permission from the National Environmental Balancing Bureau, December 1996.

Diffuser-type casings collect water from the impeller and discharge it parallel with the pump shaft. Seven types of pumps used in hydronic systems are shown in Figure E-38. Several variations of these pumps are available from the many manufacturers who construct these pumps for particular applications.

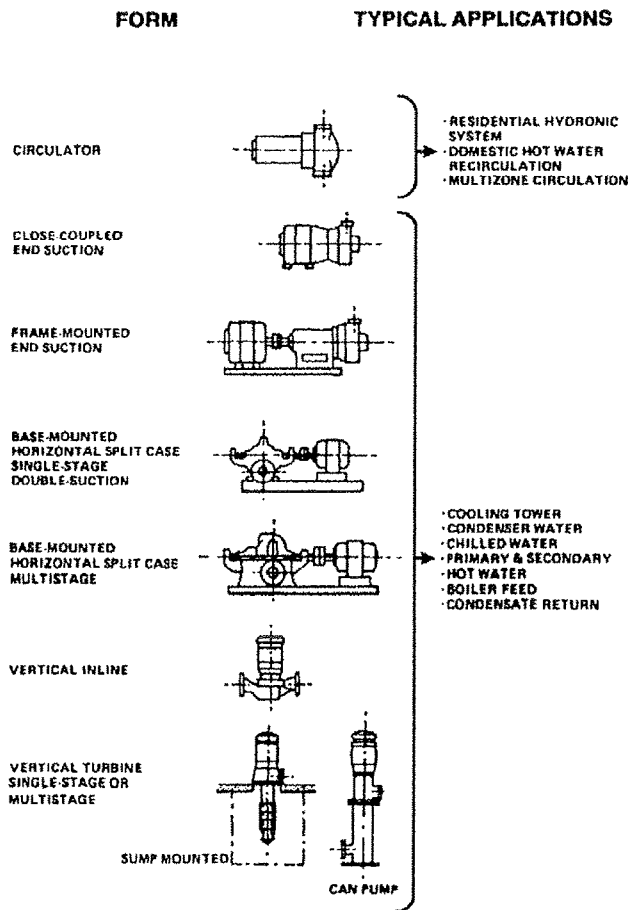

Figure E-38. Hydronic Pumps used in Hydronic Systems.

Reproduced with permission from the National Environmental Balancing Bureau, December 1996.

Circulators

These are low-head motor driven pumps suitable for heads in the pressure range from 8 to 30 ft at shut off. They are built to be installed in the piping and supported by it. The suction and discharge are inline and have bolted flanges for easy installation. The pipe run may be either vertical or horizontal if the shaft of the motor is horizontal. Figure E-39 depicts an inline circulator.

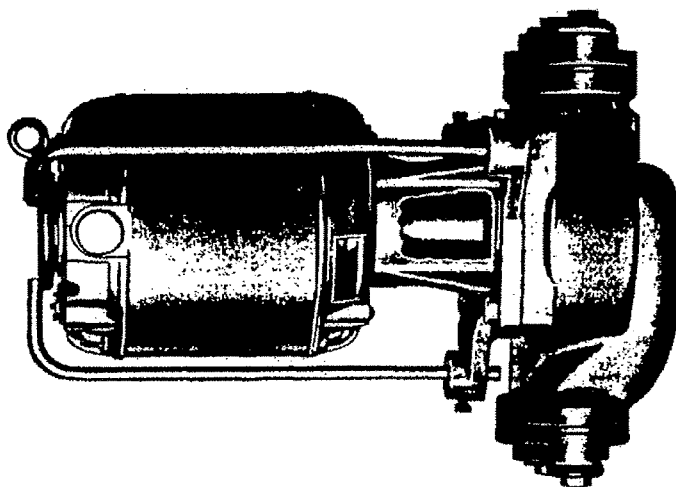

Figure E-39. Circulator (Inline).

Illustration courtesy of Dunham-Bush, Inc.

Close Coupled Centrifugal Pumps

These pumps have the impeller overhung on the motor shaft. They are compact, can operate in many positions, use simple piping arrangements, and have comparatively low cost for the capacity. An illustration of this pump is shown in Figure E-40.

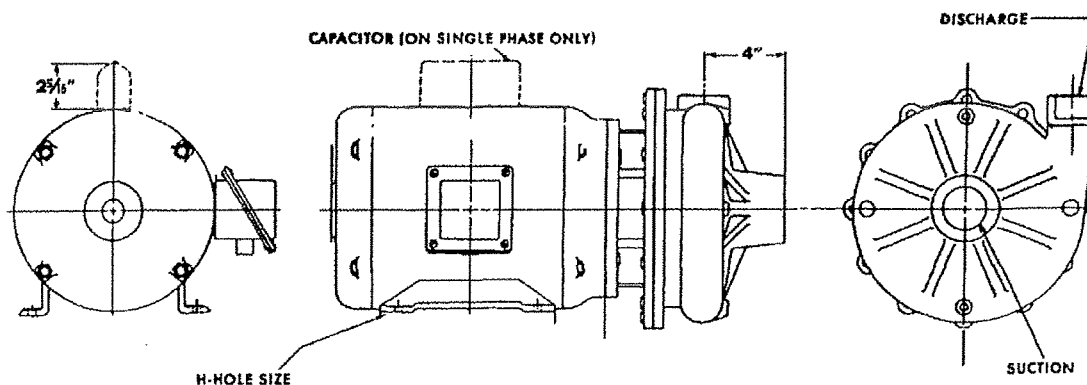

Figure E-40. Close Coupled Centrifugal Pump.

Illustration courtesy of Dunham-Bush, Inc.

Horizontal Base Mounted Pumps

The special design of this pump is for particular quietness, so hydronic systems having radiation, fan-coil units, or piping in occupied spaces may be kept at low levels of noise. The connections are flanged and the case is suitable to 125 psig. Figure E-41 shows the horizontal base mounted pump.

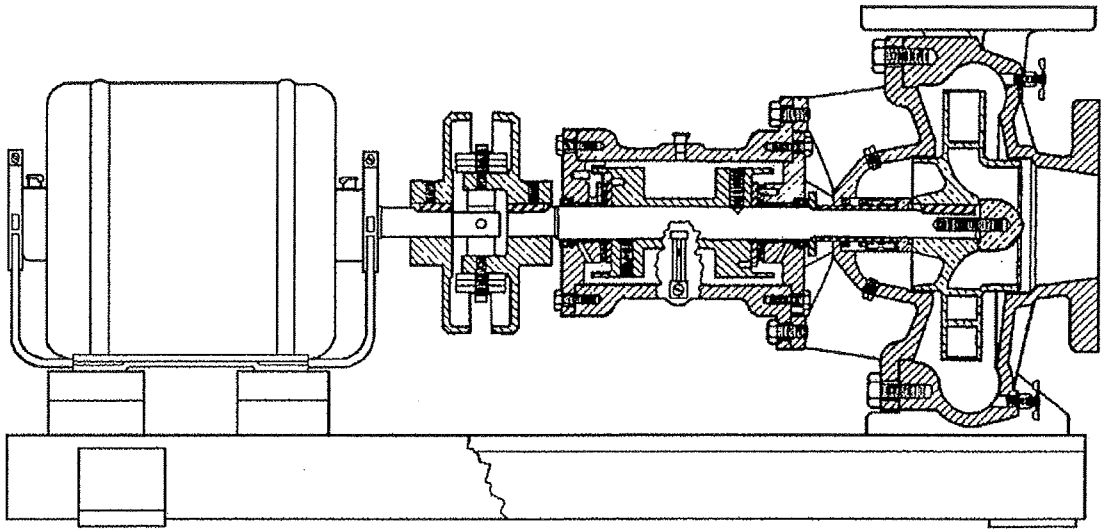

Figure E-41. Horizontal Base Mounted Pump.

Illustration courtesy of Dunham-Bush, Inc.

Horizontal Split Case Pump

These pumps (Figure E-42) usually handle larger capacities in large systems and tend to vibrate and send off low-frequency noise. With this type of pump, it is usually necessary to install an inertia base with springs. The capacity in gallons per minute for this pump is approximately 3000 gpm.

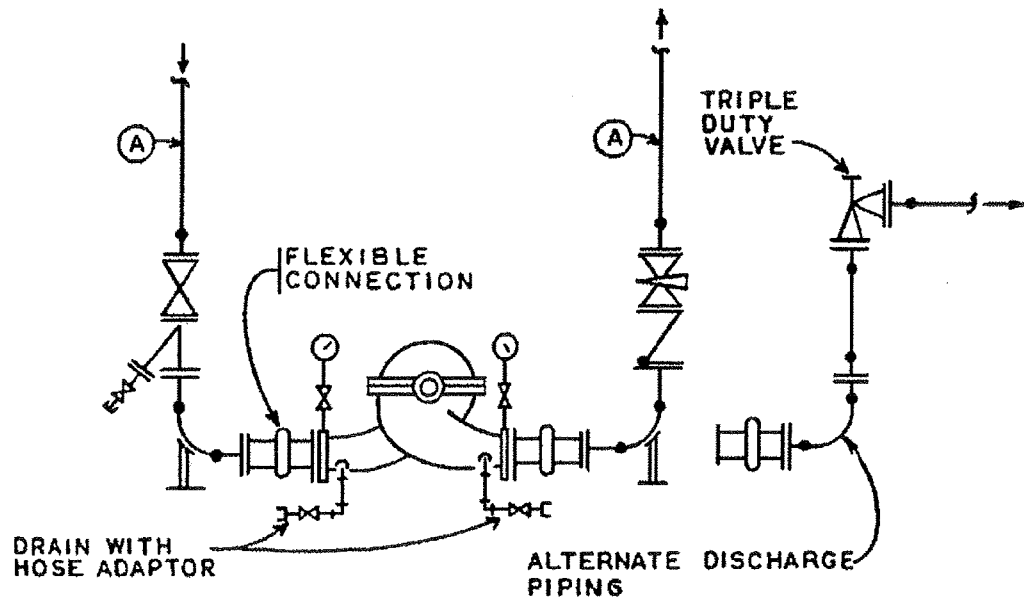

Figure E-42. Centrifugal Horizontal Split-Case Pump.

Source: Mechanical Contracting Foundation, "Guideline for Quality Piping Installation--1995," Rockville, MD. Used with permission.

Centrifugal Pump Components

Being able to identify the parts of a pump and knowing their function are the key elements in being able to identify maintenance needs. An important part of maintenance is to assure the most efficient use of all system components. The following terms will be helpful in this process:

- *Wearing rings* are for the impeller and/or casing. They are replaceable and prevent water to the impeller or casing.
- *Ball bearings* are used most frequently, except in small pumps or circulators where motor and pump bearings are the sleeve type.
- *Shaft sleeves* protect the motor or pump shaft, especially with packing.
- *Materials* that make up the centrifugal pump are generally of bronze or iron-fitted construction. In bronze-fitted construction, the impeller, shaft sleeve (if used), and wearing rings are bronze, and the casing is cast iron.
- A stuffing box is the part of the pump where the rotating shaft enters the pump casing. To seal pumps at this point, a mechanical seal or packing is used in the stuffing box.

- Balanced and unbalanced seals refer to the pressures on each side of the mechanical seal. Balanced seals are used for higher pressure seals. Inside seals operate inside the stuffing box, while outside seals have their rotating element outside the box.
- Packing is used where abrasive substances included in the water are not detrimental to system operation. Some leakage at the packing gland is needed to lubricate and cool the area between packing material and shaft.
- A balance ring is placed on the back side of a single-inlet, enclosed impeller to reduce the axial load. Double-inlet impellers are inherently balanced axially.
- Rotation is fixed by the configuration and type of vanes, and the suction and discharge connections. In addition, an arrow to indicate proper direction is often cast directly into the casing metal.

CAUTION: Pumps with mechanical seals must not be run dry, even when bumped to determine rotation.

- Operating speeds of motors usually are between 600 and 3600 rpm. The most common speed is 1800 rpm. Low speeds are generally quieter, while high speeds are less expensive.

Cavitation

Water, the fluid usually being pumped, generally contains some entrained air that has been absorbed when the fluid was exposed to the atmosphere before introduction into the system. As the fluid temperature in the system is increased, air separates out. This separation may also occur when fluid pressure is decreased. This air can be vented off somewhere in the system where there are low pressures. If fresh water is added to the system, additional venting must take place.

If air is released from the water due to low pressures and/or the liquid turns to steam, the pump (being designed for liquids) is unable to cope, and the flow of liquid is either greatly reduced or stopped completely. But at some point within the pump where the impeller produces sufficient pressure, the bubbles of gaseous liquid will be reliquified, and the bubbles of air will be reabsorbed.

The transition occurs suddenly and is accompanied by crackling or explosive noises. This noise is caused by cavitation and may cause destructive pitting and wearing of the impeller and casing as well as noise and vibration. Pump performance will be reduced by any one of these conditions.

Pump Installation Considerations

The following are some important points to remember when installing a pump:

- Suction piping should be air tight and free of air traps.
- Piping should provide a smooth flow into the suction without unnecessary elbows.
- Suction pipe should be one or two sizes larger than pump inlet.
- Reduce or eliminate restrictions at pump suction.
- Piping supported independently of pump casing.
- Use a check valve in the pump discharge piping in multi-pump installations.
- Install air vents in pump casings and piping.
- Position pressure gauges on suction and discharge at same elevation.
- Recheck pump alignment after installation.
- Lubricate prior to start up.
- Check rotation, but do not run mechanical seals while they are dry.

Pumping in Parallel

When two pumps are piped in parallel, the delivery from one pump will not necessarily be one-half the capacity of the two pumps operating together.

Each pump should be valved separately so the total capacity may be evenly divided among the pumps. Figure E-43 illustrates parallel pumps with individual valves.

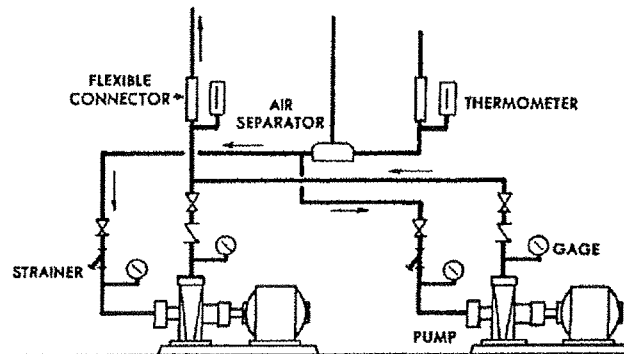

Figure E-43. Parallel Pumps with Individual Valves.

Illustration courtesy of Dunham-Bush, Inc.

When regulating the pumps, the capacity must not be so restricted that it causes an appreciable rise in temperature. This rise would increase the vapor pressure considerably. Should this happen, the pump could reach its cavitation limit and cease delivering water.

Pumping in Series

Pumps that are arranged in series discharge from one pump and deliver that same discharge into the suction end of the next pump delivering against a higher head pressure. This action is to deliver against a pressure equivalent to the sum of the heads of the two pumps. When two pumps are used for this purpose, it is called booster service.

When using pumps in series, the maximum flow will be limited by the smaller of the aggregate pumping capacity. In hydronic systems, pumps are operated in series, with one pump circulating water in a circuit supplying water to one or more other circuits or zones, each of which includes its own pump. This is called primary-secondary pumping. Figure E-44 diagrams the use of pumps in series.

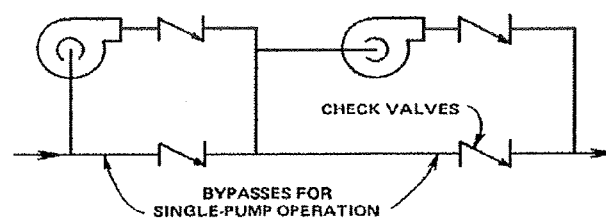

Figure E-44. Series Pumping.

7 Acceptance Testing

Before an individual or acceptance testing team begins work, it is only reasonable that an inspection of the entire system be made to confirm that all parts are on the system and ready to function. Listed below are certain key items to check before acceptance testing work begins.

Acceptance Testing Checklist

The following are items that would commonly be verified during acceptance testing. A checklist has been provided for recording data.

Coils and Heat Exchangers

- Confirm size and physical data.
- Verify air flow direction.
- Confirm provisions for pressure and temperature measurements.

Pumps

Verify:

- Equipment matches test report data (model number, make, type, etc.).
- Test report forms have had data entered that must be obtained in the field.
- All bearings have been lubricated.
- Rotation is free and correct.
- Motors have been aligned properly with pump shafts and fastened securely.

- Pump bases have been correctly grouted.
- Air has been bled from pump casing where required.
- All equipment is clean and free of foreign objects.
- Drive guards are in place.
- System pressure and temperature combinations at pump inlets are checked for possible flashing and cavitation problems.
- All strainers are clean.

The following checklist could be carried on site to perform a portion of the hydraulics inspection.

HYDRONIC SYSTEM ACCEPTANCE TESTING CHECKLIST

PROJECT: _____

LOCATION: _____

NAME: _____

A. Coils	Correct		Date Checked
	yes	no	
1. Obstruction/debris			
2. Airflow and direction			
3. Air vents			
4. Piping connections and flow direction			
5. Pressure drop across coils			
6. Size			
7. Free of leaks			
8. Strainer installed			
9. Can coil be removed?			
10. Isolation valves installed			
11. Condition of fins			
12. Temperature across coils			
13. Correct flow (gpm)	Design	TAB	Actual

B. Pumps-Motors	Correct		Date Checked
	yes	no	
1. Make, model numbers, etc.			
2. Test report forms completed			
3. Clean and free of foreign objects			
4. Rotation			
5. Lubrication			
6. Alignment/securely fastened			
7. Guards in place			
8. Pressure gauges installed			
9. Power available			
10. Disconnects installed and labeled			
11. Interlocks functional			

C. Pumps-Piping	Correct		Date Checked
	yes	no	
1. Flexible connectors			
2. Connections			
3. Pressure and temperature at pump inlet			
4. Air bled from casing where required			
5. Free of leaks			
6. Strainer clean			
7. Air vented			
8. Piping system pressure tested			
9. Pipes labeled			
10. Valves tagged			
11. Chemical treatment installed			
12. Water treatment report submitted			
13. TAB complete and approved			
14. Correct flow (gpm)	Design	TAB	Actual

D. Pumps-Bases	Correct		Date Checked
	yes	no	
1. Vibration isolation			
2. Grouting			
3. Leveling			

E. Heat Exchangers	Correct		Date Checked
	yes	no	
1. Flow and connections			
2. Air vents			
3. Leakage			

F. Hydronic Piping Systems	Correct		Date Checked
	yes	no	
1. Leak tested			
2. Relief or safety valves			
3. Compression tanks and air vents			
4. Strainers clean			
5. System installed as per plans			

Basic Hydronic System TAB Procedures

The following list is a set of procedures basic to all types of hydronic distribution systems. This list originated and may be found in the National Environmental Balancing Bureau manuals for TAB. The purpose of this summary is to provide the acceptance testing team with a concise outline of what the TAB contractor was supposed to have done during TAB.

- See that all necessary electrical wiring, temperature control systems, all related hydronic piping circuits, and all related duct systems are functional, and that any necessary compensation for seasonal effects have been made.
- Determine that hydronic systems have been cleaned, flushed, refilled, and vented as required.
- Determine that manual valves are open or preset as required, and all temperature control (automatic) valves are in the normal position.
- Determine that automatically controlled devices in the piping or duct systems will not adversely affect the balancing procedures.
- With pump(s) off, observe and record system static pressure at the pump(s).
- Place systems into operation, check that all air has been vented from the piping systems, and allow flow conditions to stabilize.
- Record operating voltage and amperage, and compare these with nameplate ratings and thermal overload heater ratings.
- Record speed of each pump.
- With pump(s) running, slowly close the balancing cock in pump discharge piping, and record discharge and suction pressures at the pump gauge connections. Using shut-off head, determine and verify each actual pump operating curve and the size of each impeller. Compare this data with the submittal data curves. If the test point falls on the design curve, proceed to the next step; if not, plot a new curve parallel with other curves on the chart, from zero flow to maximum flow. Make sure the test readings were taken correctly before plotting a new curve. Preferably one gauge should be used to

read differential pressure. It is important that gauge readings should be corrected to the center line elevation of the pump.

- Open discharge balancing cock slowly to a fully open position, and record the discharge pressure, suction pressure, and total head. Using the total head, read the system water flow from the corrected pump curve established above. If the total head is higher than the design total head, the water flow will be lower than designed. If the total head is less than design, water flow will be greater; in which case, the pump discharge pressure should be increased by partially closing the balancing cock until the system water flow is approximately 110 percent of design. Record the pressures and the water flow. Check and record pump motor voltage and amperage. This data should still be within the motor nameplate ratings. Start any secondary system pumps and readjust the balancing cock in the primary circuit pump discharge piping if necessary. Again record all readings.
- If orifice plates, venturi meters, or other flow measuring or control devices have been provided in the water piping system, an initial recording of the flow distribution throughout the system should be made without making any adjustments. After studying the system, adjust the distribution branches or risers to achieve balanced circuits as outlined above. Vent air from low flow circuits. Then proceed with the balancing of terminal units on each branch.
- Before adjusting any balancing cocks at the equipment (i.e., chillers, boilers, hot water exchangers, hot water coils, chilled water coils, etc.), take a complete set of pressure drop readings through all equipment and compare with submittal data readings. Determine which are high and which are low in water flow. Vent air from low flow circuits or units and retake readings.
- Make a preliminary adjustment to the balancing cocks on all units with high water flow, setting each about 10 percent higher than the design flow rate.
- Take another complete set of pressure, voltage, and ampere readings on all pumps in the system. If the system total flow has fallen below design flow, open the balancing cock at each pump discharge to bring the flow at each pump within 105 to 110 percent of the design reading (if pump capacity permits).

- Make another adjustment to the balancing cocks on all units that have readings more than 10 percent above design flow in order to increase the flow through those units with less than design flow.
- Repeat this process until the actual fluid flow through each piece of equipment is within ± 10 percent of the design flow.
- Make a final check of and record the pressures and flows of all pumps and equipment and of the voltage and amperage of pump motors.
- Where three-way automatic valves are used, set all bypass line balancing cocks to restrict the bypassed water to 90 percent of the maximum demand through coils, heat exchangers, and other terminal units.
- After all TAB work has been completed and the systems are operating within ± 10 percent of design flow, mark or score all balancing cocks, gauges, and thermometers at final set points or range of operation.
- Verify the action of all water flow safety shutdown controls.

Glossary

ALCOVE: A recessed section of a room, such as a breakfast nook.

AMPERAGE: The strength of an electric current measured in amperes.

ATMOSPHERIC AIR: Air under the prevailing conditions of the atmosphere.

CONDENSATE: The liquid formed by condensation of a vapor: in steam heating, water condensed from steam; in air conditioning, water extracted as by condensation on the cooling coil of a refrigeration machine.

ENTRAINED AIR: Air that has been absorbed or suspended in water. As water heats up, air separates out and stores in high spots of a hydronic system.

GAGE GLASS: The transparent part of a water gauge assembly connected directly or through a water column to the boiler, below and above the water line to indicate the water level in a boiler. It is sometimes located in compression tanks to observe the water level.

GRAVITY CONVECTION: The transmission of heat by the circulation of a liquid or a gas such as air due to the forces of gravity.

HEAT EXCHANGER: A vessel in which heat is transferred from one medium to another.

HEAT TRANSFER: A form of energy in motion from one object to another caused by a temperature difference.

HEAT TRANSFER MEDIUM: Matter that transports energy from one body to another. The matter involved could be water, steam, vapor, or solids such as steel, copper, plastic, etc.

HYGROSCOPIC: Attracting or absorbing moisture from the air.

INTERIOR ROOM: A room with its own walls that are enveloped within another room or perimeter walls of a building.

MAKE-UP WATER: The water added to boiler feed to compensate for that lost through exhaust, blowdown, leakage, etc.

STATIC HEAD: The pressure due to the weight of the fluid above the point of measurement. The units of head are pounds per square inch or Pascals.

VENTILATION AIR: Outside air brought into the building by use of a mechanical system.

VENTING: The removal of a gas or vapor through an opening in a vessel or other enclosed space.

VOLTAGE: The electromotive force or difference in electric potential expressed in volts.

WET BULB TEMPERATURE: The lowest temperature that a water wetted body will attain when exposed to an air current. This is the temperature of adiabatic saturation.

ZONE: The specific section of a building controlled by a single thermostat. Buildings may be divided into many zones.

Bibliography

American Society of Heating, Refrigerating and Air-Conditioning Engineers (ASHRAE), *Systems and Equipment Handbook*, ASHRAE, Atlanta, GA, 1996.

ASHRAE, *Fundamentals Handbook*, ASHRAE, 1997.

Armstrong Capsulated Controlled Steam Traps, Bulletin No. 131-D10M 3/85-0, Armstrong, Three Rivers, MI.

Pressure Drop Calculations in Hydronic Systems, Bulletin No. TEH-571, File 160110, Bell & Gossett ITT, Lenexa, KS, 1971.

Heating and Cooling Coils, Burnham Corporation, Hydronics Division, Lancaster, PA.

Cash Automatic Valves ACME, Bulletin Reg. 1e, Nov. 1, 1978, A. W. Cash Valve Manufacturing Corp., Decatur, IL.

Cengel, Yunus A., Boles, Michael A., *Thermodynamics*, McGraw-Hill Inc., St. Louis, MO, 1989.

Dukelow, S.G., *Improving Boiler Efficiency*, Cooperative Extension Service, Kansas State University, Manhattan, KS, 1983.

Hydronics Manual, Dunham-Bush, Inc., West Hartford, CT, 1963.

The World Book Encyclopedia, Volume 17, Field Enterprises, Inc., Chicago, Illinois, 1951.

National Environmental Balancing Bureau (NEBB), *Environmental Systems Technology*, NEBB, Vienna, VA, 1984.

NEBB, *Procedural Standards for Testing, Adjusting, Balancing of Environmental Systems, 4th Edition*, NEBB, 1983.

Webster's New World Dictionary, 2nd College Edition, Simon & Schuster, Inc., Springfield, MA, 1986.