



Online Continuing Education for Professional Engineers
Since 2009

Design of Wood and Light Frame Construction

PDH Credits:

4 PDH

Course No.:

WLF101

Publication Source:

US NAVFAC

"Engineering Aide Guide

Ch. 6 – Wood and Light Frame Structures"

DISCLAIMER:

All course materials available on this website are not to be construed as a representation or warranty on the part of Online-PDH, or other persons and/or organizations named herein. All course literature is for reference purposes only, and should not be used as a substitute for competent, professional engineering council. Use or application of any information herein, should be done so at the discretion of a licensed professional engineer in that given field of expertise. Any person(s) making use of this information, herein, does so at their own risk and assumes any and all liabilities arising therefrom.

CHAPTER 6

WOOD AND LIGHT FRAME STRUCTURES

When you prepare an engineering drawing, regardless of type, you are required to apply knowledge of the materials and methods of construction. This chapter describes the uses, kinds, sizes, grades, and other classifications of wood as they apply to light frame building construction; the various structural members and their functions; and the different types of finishing hardwares and fasteners used.

WOOD

Of the different construction materials, wood is probably the most often used and perhaps the most important. The variety of uses of wood is practically unlimited. Few SEABEE construction projects, whether involving permanent or temporary structures, are built without using wood. Temporary uses of wood include scaffolding, shoring, bracing, and miscellaneous concrete forms.

There are several types or species of wood. Each type has its own characteristics and its recommended uses. For most large projects, the types and classifications of wood are given in the project specifications. For smaller projects that DO NOT have written specifications, the types and classifications of wood are included in the drawings. The types, sources, uses, and characteristics of common woods are given in table 6-1. In addition, the species, size classification, and design values of common structural woods are also listed in the *Architectural Graphic Standards*.

LUMBER

In construction, the terms *wood*, *lumber*, and *timber* have distinct, separate meanings. WOOD is the hard, fibrous substance that forms the major part of the trunk and branches of a tree. LUMBER is wood that has been cut and surfaced for construction use. TIMBER is lumber whose

smallest dimension is NOT less than 5 in. Another term, *MILLWORK*, refers to manufactured lumber products, such as doors, window frames, window casings, shutters, interior trim, cabinets, and moldings.

Sizes

Standard lumber sizes have been established in the United States to permit uniformity in planning structures and in ordering materials. Lumber is identified by NOMINAL SIZES. The nominal size of a piece of lumber is larger than the actual DRESSED dimensions. Dressed lumber has been SURFACED (planed smooth) on two or more sides. It is designated according to the number of sides or edges surfaced. If it has been surfaced on two sides only, the designation is S2S (surfaced 2 sides); if surfaced on all four sides, S4S (surfaced 4 sides); or if surfaced on two sides and two edges, S2S2E. Lumber is ordered and designated on drawings by its nominal size rather than by its dressed dimensions. Common widths and thicknesses of lumber in nominal and dressed dimensions are shown in table 6-2.

Classification

Lumber is classified according to its USE, SIZE, and EXTENT OF MANUFACTURE. When classified according to use, lumber falls into three categories:

1. YARD LUMBER—grades, sizes, and patterns generally intended for ordinary construction and general building purposes
2. STRUCTURAL LUMBER—2 or more in. in thickness and width for use where working stresses are required
3. FACTORY AND SHOP LUMBER—produced or selected mainly for manufacture of furniture, doors, cabinets, and other millwork

Table 6-1.-Common Woods

Type	Sources	Uses	Characteristics
Ash	East of Rockies . .	Oars, boat thwarts, benches, gratings, hammer handles, cabinets, ball bats, wagon construction farm implements.	Strong, heavy, hard, tough; elastic, close straight grain, shrinks very little, takes excellent finish, lasts well.
Balsa	Ecuador	Rafts, food boxes, linings of refrigerators, life preservers, loud speakers, sound-proofing, air-conditioning devices, model airplane construction.	Lightest of all woods, very soft, strong for its weight, good heat insulating qualities, odorless.
Basswood .	Eastern half of U.S. with exception of coastal regions.	Low-grade furniture, cheaply constructed buildings, interior finish, shelving, drawers, boxes, drainboards, woodenware, novelties, excelsior, general millwork.	Soft, very light, weak, brittle, not durable, shrinks considerably, inferior to poplar, but very uniform, works easily, takes screws and nails well and does not twist or warp.
Beech	East of Mississippi, Southeastern Canada.	Cabinetwork, imitation mahogany furniture, wood dowels, capping, boat trim, interior finish, tool handles, turnery, shoe lasts, carving, flooring.	Similar to birch but not so durable when exposed to weather, shrinks and checks considerably, close grain, light or dark red color.
Birch	East of Mississippi River and North of Gulf Coast States, Southeast Canada, Newfoundland.	Cabinetwork, imitation mahogany furniture, wood dowels, capping, boat trim, interior finish, tool handles, turnery, carving.	Hard, durable, fine grain, even texture, heavy, stiff, strong, tough, takes high polish, works easily, forms excellent base for white enamel finish, but not durable when exposed. Heartwood is light to dark reddish brown in color.
Butternut	Southern Canada, Minnesota, Eastern U. S. as far south as Alabama and Florida.	Toys, altars, woodenware, millwork, interior trim, furniture, boats, scientific instruments.	Very much like walnut in color but softer, not so soft as white pine and basswood, easy to work, coarse grained, fairly strong.

Table 6-1.-Common Woods—Continued

Type	Sources	Uses	Characteristics
Cypress	Maryland to Texas, along Mississippi valley to Illinois.	Small boat planking, siding, shingles, sash, doors, tanks, silos, railway ties.	Many characteristics similar to white cedar. Water resistant qualities make it excellent for use as boat planking.
Douglas Fir . .	Pacific Coast, British Columbia.	Deck planking on large ships, shores, strongbacks, plugs, filling pieces and bulkheads of small boats, building construction, dimension timber, plywood.	Excellent structural lumber, strong, easy to work, clear straight grained, soft, but brittle. Heartwood is durable in contact with ground, best structural timber of northwest.
Elm	States east of Colorado.	Agricultural implements, wheel-stock, boats, furniture, crossties, posts, poles.	Slippery, heavy, hard, tough, durable, difficult to split, not resistant to decay.
Hickory	Arkansas, Tennessee, Ohio, Kentucky.	Tools, handles, wagon stock, hoops, baskets, vehicles, wagon spokes.	Very heavy, hard, stronger and tougher than other native woods, but checks, shrinks, difficult to work, subject to decay and insect attack.
Lignum Vitae	Central America.	Block sheaves and pulleys, waterexposed shaft bearings of small boats and ships, tool handles, small turned articles, and mallet heads.	Dark greenish brown, unusually hard, close grained, very heavy, resinous, difficult to split and work, has soapy feeling.
Live Oak . . .	Southern Atlantic and Gulf Coasts of U.S., Oregon, California.	Implements, wagons, ship building.	Very heavy, hard, tough, strong, durable, difficult to work, light brown or yellow sap wood nearly white.
Mahogany . . .	Honduras, Mexico, Central America, Florida, West Indies, Central Africa, other tropical sections.	Furniture, boats, decks, fixtures, interior trim in expensive homes, musical instruments.	Brown to red color, one of most useful of cabinet woods, hard, durable, does not split badly, open grained, takes beautiful finish when grain is filled but checks, swells, shrinks, warps slightly.

Table 6-1.-Common Woods—Continued

Type	Sources	Uses	Characteristics
Maple	All states east of Colorado, Southern Canada.	Excellent furniture, high-grade floors, tool handles, ship construction cross-ties, counter tops, bowling pins.	Fine grained, grain often curly or "Bird's Eyes," heavy, tough, hard, strong, rather easy to work, but not durable. Heartwood is light brown, sap wood is nearly white.
Norway Pine	States bordering Great Lakes.	Dimension timber, masts, spars, piling, interior trim.	Light, fairly hard, strong, not durable in contact with ground.
Philippine Mahogany . .	Philippine Islands	Pleasure boats, medium-grade furniture, interior trim.	Not a true mahogany, shrinks, expands, splits, warps, but available in long, wide, clear boards.
Poplar	Virginias, Tennessee, Kentucky, Mississippi Valley.	Low-grade furniture cheaply constructed buildings, interior finish, shelving, drawers, boxes.	Soft, cheap, obtainable in wide boards, warps, shrinks, rots easily, light, brittle, weak, but works easily and holds nails well, fine-textured.
Red Cedar . .	East of Colorado and north of Florida.	Mothproof chests, lining for linen closets, sills, and other uses similar to white cedar.	Very light, soft, weak, brittle, low shrinkage, great durability, fragrant scent, generally knotty, beautiful when finished in natural color, easily worked.
Red Oak . . .	Virginias, Tennessee, Arkansas, Kentucky, Ohio, Missouri, Maryland.	Interior finish, furniture, cabinets, millwork, crossties when preserved.	Tends to warp, coarse grain, does not last well when exposed to weather, porous, easily impregnated with preservative, heavy, tough, strong.
Redwood . .	California.	General construction, tanks, paneling.	Inferior to yellow pine and fir in strength, shrinks and splits little, extremely soft, light, straight grained, very durable, exceptionally decay resistant.

Table 6-1.-Common Woods—Continued

Type	Sources	Uses	Characteristics
Spruce	New York, New England, West Virginia, Central Canada, Great Lakes States, Idaho, Washington, Oregon.	Railway ties, resonance wood, piles, airplanes, oars, masts, spars, baskets.	Light, soft, low strength, fair durability, close grain, yellowish, sap wood indistinct.
Sugar Pine	California, Oregon.	Same as white pine.	Very light, soft, resembles white pine.
Teak	India, Burma, Siam, Java.	Deck planking, shaft logs for small boats.	Light brown color, strong, easily worked, durable, resistant to damage by moisture.
Walnut	Eastern half of U.S. except Southern Atlantic and Gulf Coasts, some in New Mexico, Arizona, California.	Expensive furniture, cabinets, interior woodwork, gun stocks, tool handles, airplane propellers, fine boats, musical instruments.	Fine cabinet wood, coarse grained but takes beautiful finish when pores closed with woodfiller, medium weight, hard, strong, easily worked, dark chocolate color, does not warp or check, brittle.
White Cedar	Eastern Coast of U.S., and around Great Lakes.	Boat planking, railroad ties, shingles, siding, posts, poles.	Soft, light weight, close grained, exceptionally durable when exposed to water, not strong enough for building construction, brittle, low shrinkage, fragment, generally knotty.
White Oak . .	Virginias, Tennessee, Arkansas, Kentucky, Ohio, Missouri, Maryland, Indiana.	Boat and ship stems, stern-posts, knees, sheer strakes, fenders, capping, transoms, shaft logs, framing for buildings, strong furniture, tool handles, crossties, agricultural implements, fence posts.	Heavy, hard, strong, medium coarse grain, tough, dense, most durable of hardwoods, elastic, rather easy to work, but shrinks and likely to check. Light brownish grey in color with reddish tinge, medullary rays are large and outstanding and present beautiful figures when quarter sawed, receives high polish.

Table 6-1.-Common Woods—Continued

Type	Sources	Uses	Characteristics
White Pine.	Minnesota, Wisconsin, Maine, Michigan, Idaho, Montana, Washington, Oregon, California	Patterns, any interior job or exterior job that doesn't require maximum strength, window sash, interior trim, millwork, cabinets, cornices.	Easy to work, fine grain, free of knots, takes excellent finish, durable when exposed to water, expands when wet, shrinks when dry, soft, white, nails without splitting, not very strong, straight grained.
Yellow Pine.	Virginia to Texas.	Most important lumber for heavy construction and exterior work, keelsons, risings, filling pieces, clamps, floors, bulkheads of small boats, shores, wedges, plugs, strongbacks, staging, joists, posts, piling, ties, paving blocks.	Hard, strong, heartwood is durable in the ground, grain varies, heavy, tough, reddish brown in color, resinous, medullary rays well marked.

Nominal, rough, green lumber has three general classifications, according to size, as follows:

1. **BOARDS**—less than 2 in. thick and 1 or more in. wide. If less than 6 in. wide, they may be classified as strips.
2. **DIMENSION**—at least 2 in. thick, but less than 5 in. thick, and 2 or more in. wide. It may be classified as framing, joists, planks, rafters, studs, and small timbers.
3. **TIMBERS**—smallest dimension is 5 or more in. They may be classified as beams, stringers, posts, caps, sills, girders, and purlins.

Lumber classified by extent of manufacture consists of three types as follows:

1. **ROUGH LUMBER** is not dressed (surfaced) but sawed, edged, and trimmed to the extent that saw marks show in the wood on the four longitudinal surfaces of each piece for its overall length.
2. **DRESSED LUMBER** is surfaced by a planing machine to attain a smooth surface and uniform size.
3. **WORKED LUMBER** is dressed and also matched, shiplapped, or patterned.

Grading

According to the American Lumber Standards set by the National Bureau of Standards for the U.S. Department of Commerce, lumber is graded for quality. The major grades of yard lumber, in descending order of quality, are **SELECT LUMBER** and **COMMON LUMBER**. Each of these grades is subdivided, also in descending order of quality.

SELECT LUMBER has a good appearance and good qualities for finishing. One kind of select lumber is suitable for natural finishes; another kind, for painted finishes. Select lumber for natural finishes is graded A or B. Grade A is nearly free of defects and blemishes, but Grade B contains a few minor blemishes. Select lumber for painted finishes is Grade C or D. The blemishes in Grade C are more numerous and significant than those in Grade B. Grade D has even more blemishes than Grade C does. Either grade, C or D, presents a satisfactory appearance when painted.

COMMON LUMBER is suitable for general construction and utility purposes. It, also, is subdivided by grade in descending order of quality. No. 1 common is sound, tight-knotted stock, containing only a few minor defects. It must be suitable for use as watertight lumber.

Table 6-2.-Nominal and Dressed Sizes of Lumber

Item	Thickness (Inches)		Face Width (Inches)	
	Nominal	Dressed	Nominal	Dressed
Boards	1 1 1/4 1 1/2	3/4 1 1 1/4	2	1 1/2
			3	2 1/2
			4	3 1/2
			5	4 1/2
			6	5 1/2
			7	6 1/2
			8	7 1/4
			9	8 1/4
			10	9 1/4
			11	10 1/4
			12	11 1/4
Dimension Lumber	2 2 1/2 3 3 1/2	1 1/2 2 2 1/2 3	14	13 1/4
			16	15 1/4
			2	1 1/2
			3	2 1/2
			4	3 1/2
			5	4 1/2
			6	5 1/2
			8	7 1/4
Dimension Lumber	4 4 1/2	3 1/2 4	10	9 1/4
			12	11 1/4
			2	1 1/2
			3	2 1/2
			4	3 1/2
			5	4 1/2
Timbers	5 & Thicker		5 & Wider	

No. 2 common contains a limited number of significant defects but no knotholes or other serious defects. It must be suitable for use as grain-tight lumber. No. 3 common contains a few defects, larger and coarser than those in No. 2; for example, occasional knotholes. No. 4 is low-quality material, contains serious defects like knotholes, checks, shakes, and decay. No. 5 common holds together only under ordinary handling.

STRUCTURAL LUMBER is graded according to allowable stresses that determine its safe

load-carrying capacity. This capacity is based on various factors, such as species of the wood, density, moisture content, and other characteristics that affect the strength of the lumber. Factory and shop lumber is generally graded by its intended use; the grades vary greatly from use to use.

Board Measure

The basic unit of quantity for lumber is called a BOARD FOOT. It is defined as the volume of

LAMINATED LUMBER

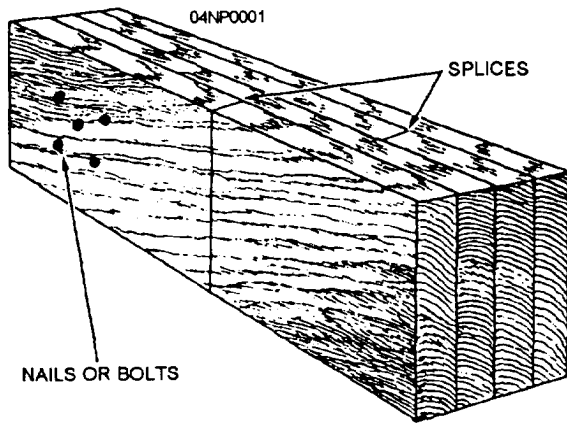

Figure 6-1.-Example of a laminated lumber.

a board 1 ft long by 1 ft wide by 1 in. thick. Since the length of lumber is usually measured in feet, the width in inches, and the thickness in inches, the formula for the quantity of lumber in board feet becomes the following:

$$\frac{\text{Thickness (inches)} \times \text{width (inches)} \times \text{length (feet)}}{12} = \text{board measure (board feet)}$$

Example: Calculate the board measure of a 14-ft length of a 2 by 4. Applying the formula, you get

$$\frac{2 \times 4 \times 14}{12} = 9 \frac{1}{3}$$

Lumber less than 1 in. thick is presumed to be 1 in. thick for board measure purposes. Board measure is calculated on the basis of the nominal, not the dressed, dimensions of lumber. The symbol for board feet is bm, and the symbol for a unit of 1,000 is M. If 10,000 board feet of lumber were needed, for example, the quantity would be 10Mbm.

Laminated lumber is commonly used when increased wood load-carrying capacity and rigidity are required. Usually made of several pieces of 1 1/2-in. -thick lumber, called laminations, the pieces are nailed, bolted, or glued together with the grain of all pieces running parallel (fig. 6-1). When extra length is needed, the pieces are spliced with the splices staggered so that no two adjacent laminations are spliced at the same point. Built-up beams and girders are examples of laminated lumber.

Laminations may be used independently or with other materials in the construction of a structural unit. Trusses can be made with laminations for the chords and sawed lumber for the web members (fig. 6-2). Special beams (fig. 6-3) may be constructed with laminations for the flanges and sawed lumber for the webs.

Probably the greatest use of laminations is in the fabrication of large beams and arches. Beams with spans larger than 100 ft and depths of 8 1/2 ft have been constructed with 2-in. boards. Laminations this large are factory-produced. They are glued together under pressure. Most laminations are spliced using scarf joints (fig. 6-4), and the entire piece is dressed to ensure uniform thickness and width.

PLYWOOD

Plywood is a panel product made from thin sheets of wood called veneers. An odd number of veneers, such as three, five, or seven, is generally used so the grains on the face and back of the panel run in the same direction. Cross-lamination (fig. 6-5) distributes the grain strength in both directions, creating a panel that resists splitting and, pound for pound, one of the strongest building materials available.

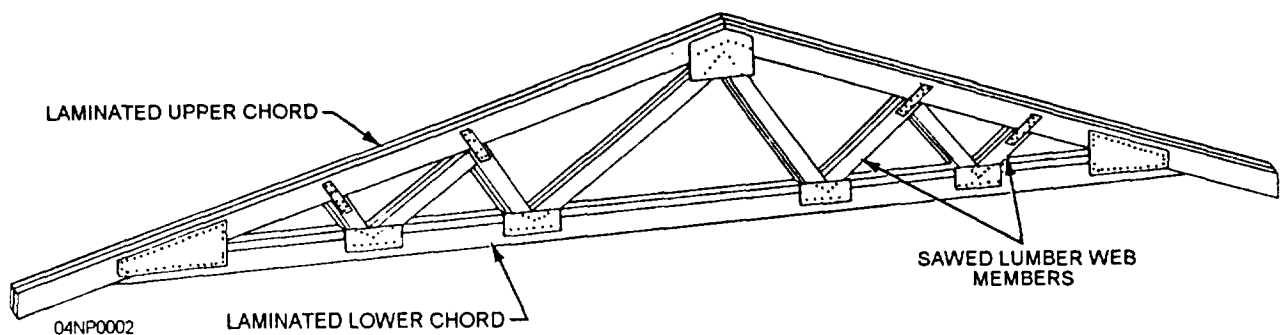

Figure 6-2.-Truss using laminated and sawed lumber.

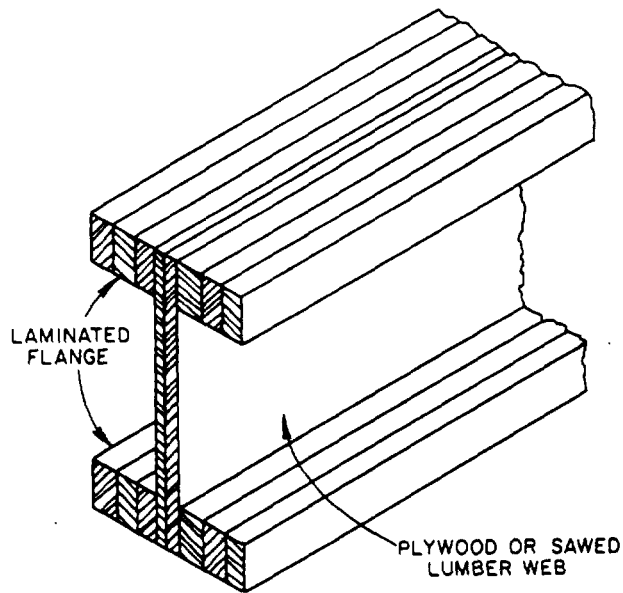

Figure 6-3.-Laminated and sawed lumber or plywood beam.

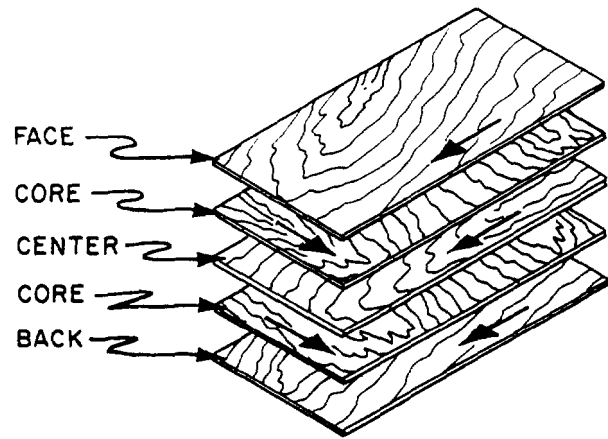

Figure 6-5.-Grain direction in a sheet of plywood.

Dry from the mill, plywood is never "green." From oven-dry to complete moisture saturation, a plywood panel swells across or along the grain only about 0.2 of 1 percent and considerably less with normal exposures.

There is probably no building material as versatile as plywood. It is used for concrete forms, wall and roof sheathing, flooring, box beams, soffits, stressed-skin panels, paneling, partitions, doors, furniture, shelving, cabinets, crates, signs, and many other purposes.

Sizes

Plywood is generally available in panel widths of 36, 48, and 60 in. and in panel lengths ranging from 60 to 144 in. in 12-in. increments. Other sizes are also available on special order. Panels 48 in. wide by 96 in. long (4 by 8 ft), and 48 in. wide by 120 in. long (4 by 10 ft), are most commonly available. The 4 by 8 ft and larger sizes simplify construction, saving time and labor.

Nominal thicknesses of sanded panels range from 1/4 to 1 1/4 in. or greater, generally in 1/8-in. increments. Unsanded panels are available in nominal thicknesses of 5/16 to 1 1/4 in. or greater, in increments of 1/8 in. for thicknesses over 3/8 in. Under 3/8 in., thicknesses are in 1/16-in. increments.

Types

Plywood is classified by type as INTERIOR or EXTERIOR. Made of high-quality veneers and more durable adhesives, exterior plywood is better than interior at withstanding exposure to the elements. Even when wetted and dried

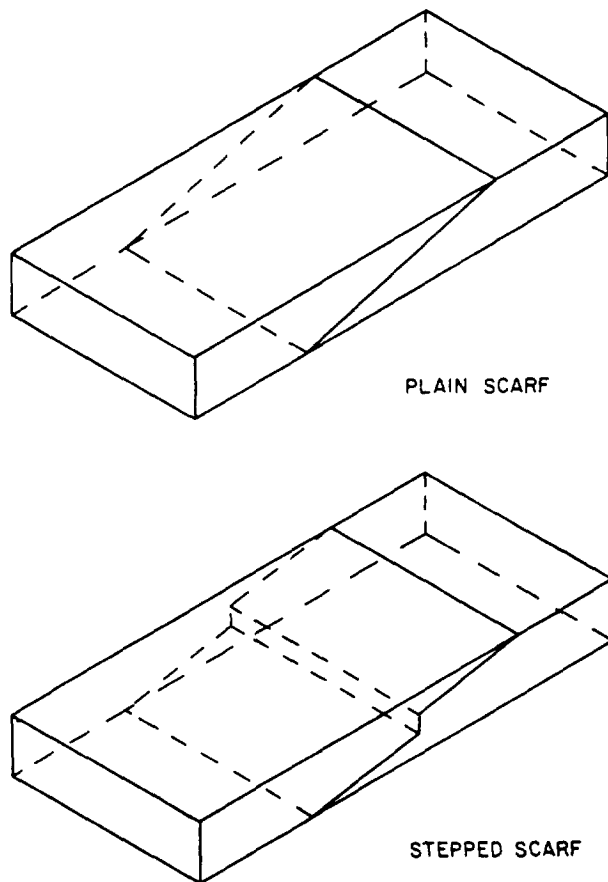

Figure 6-4.-Scarf joints.

- N—Special order natural finish veneer. Select all heartwood or all sapwood. Free of open defects. Allows some repairs.
- A—Smooth and paintable. Neatly made repairs permissible. Also used for natural finish in less demanding applications.
- B—Solid surface veneer. Circular repair plugs and tight knots permitted.
- C—Knotholes to 1 in. Occasional knot-holes 1/2 in. larger permitted providing total width of all knots and knotholes within a specified section does not exceed certain limits. Limited splits permitted. Minimum veneer permitted in exterior-type plywood.
- C—Improved C veneer with splits limited [Plgd] to 1/8 in. in width and knotholes and borer holes limited to 1/4 in. by 1/2 in.
- D—Permits knots and knotholes to 2 1/2 in. width and 1/2 in. larger under certain specified limits. Limited splits permitted.

Figure 6-6. Plywood veneer grades.

repeatedly or otherwise subjected to the weather, exterior plywood retains its glue bond and withstands exposure to the elements. Interior plywood can withstand an occasional wetting but not permanent exposure to the elements.

Grades

The several grades within each type of plywood are determined by the grade of the veneer (N, A, B, C, or D) used for the face and back of the panel (fig. 6-6). Panel grades are generally designated by the kind of glue and by the veneer grade on the back and face. Grading is based on the number of defects, such as knotholes, pitch pockets, splits, discolorations, and patches, in each face of the plywood panel.

Identification Stamps

Stamps are placed on the edges and back of each sheet of plywood so it can be properly

identified. Figure 6-7 shows typical back-stamps and edge-marks found on a standard sheet of plywood. It shows all information needed about the sheet, except its actual size.

Figure 6-8 shows the stamps found on the backs of structural and standard sheathing panels. They vary somewhat from the standard stamps.

TYPICAL BACK-STAMP

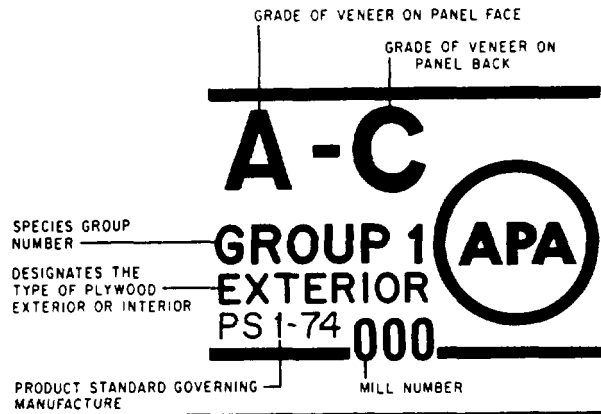

TYPICAL EDGE-MARK

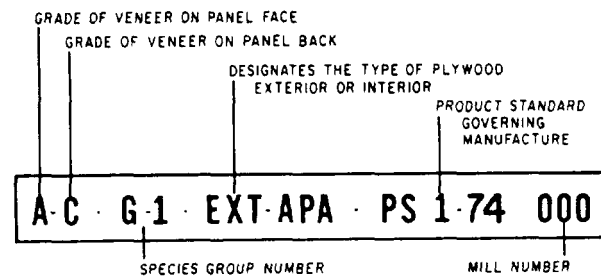

Figure 6-7. Standard plywood identification symbols.

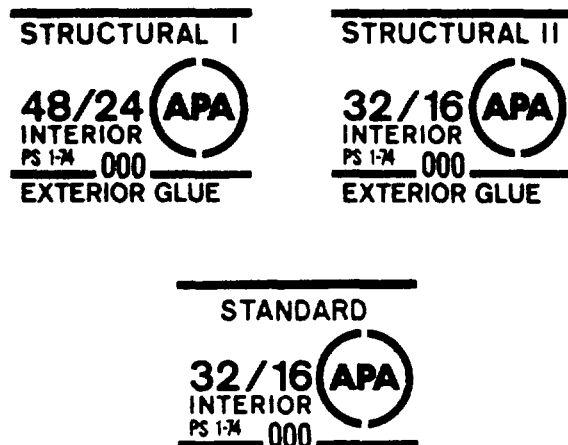

Figure 6-8. Structural and standard sheathing identification symbols.

The actual grade is NOT given, NOR is the species group. The index numbers 48/24 and 32/ 16 give the maximum spacing in inches of supports. The number to the left of the slash is the maximum O.C. (on-center) spacing of supports for roof decking. The number to the right of the slash is the maximum O.C. spacing of supports for subfloors. A number 0 on the right of the slash indicates that the panel should NOT be used for subflooring. No reference to the index number is needed when the panel is to be used for wall sheathing.

Detailed information on specific types and grades and their uses can be found in commercial standards for the manufacture of plywoods established by the U.S. Department of Commerce. General plywood characteristics and architectural information can be found in the following publications: *American Plywood Association*,

National Lumber Manufacturing Association, or the *Architectural Graphic Standards*. The latter book can be found in your unit's technical library.

SPECIAL-PURPOSE PLYWOOD

Other types of plywood are manufactured for specific purposes. Among these types are the structural, sheathing, overlaid panels, decorative panels, and concrete form panels. Table 6-3 lists some of the various types of plywood with their suggested uses.

Structural plywood is recommended for heavy-load application where strength properties are of great importance. Likewise, for box beams, gusset plates, and stressed-skin panels, unsanded grades of C-D plywood are recommended.

Standard plywood sheathing is used for subfloors, roof decks, and wall sheathing. It is

Table 6-3.-Uses of Plywood

SOFTWOOD PLYWOOD GRADES FOR EXTERIOR USES				
GRADE (EXTERIOR)	FACE	BACK	INNER PLYS	USES
A-A	A	A	C	Outdoor where appearance of both sides is important.
A-B	A	B	C	Alternate for A-A, where appearance of one side is less important.
A-C	A	C	C	Siding, soffits, fences. Face is finish grade.
B-C	B	C	C	For utility uses such as farm buildings, some kinds of fences, etc.
C-C (Plugged)	C Plugged	C	C	Excellent base for tile and linoleum, backing for wall coverings.
C-C	C	C	C	Unsanded, for backing and rough construction exposed to weather.
B-B Concrete Forms	B	B	C	Concrete forms. Re-use until wood literally wears out.
MDO	B	B or C	C or C-Plugged	Medium Density Overlay. Ideal base for paint: for siding, built-ins, signs, displays.
HDO	A or B	A or B	C-Plugged	High Density Overlay. Hard surface; no paint; needed. For concrete forms, cabinets, counter tops, tanks.

SOFTWOOD PLYWOOD GRADES FOR INTERIOR USES				
GRADE (INTERIOR)	FACE	BACK	INNER PLYS	USES
A-A	A	A	D	Cabinet doors, built-ins, furniture where both sides will show.
A-B	A	B	D	Alternate of A-A. Face is finish grade, back is solid and smooth.
A-D	A	D	D	Finish grade face for paneling, built-ins, backing.
B-D	B	D	D	Utility grade. One paintable side. For backing, cabinet sides, etc.
STANDARD	C	D	D	Sheathing and structural uses such as temporary enclosures, subfloor. Unsanded.

recommended for use in spaces that may be exposed to moisture during construction, but will be covered when construction is complete.

Overlaid panels have a resin-treated fiber-surfacing material, on one or both sides, to hold paint and finishes more readily. These exterior or interior types of plywood are recommended for use in furniture, cabinets, millwork, and exterior trims.

Decorative panels are used basically for exterior and interior wall sheathing. Both types are manufactured in a multitude of designs and patterns and can be painted, stained, or left to weather naturally.

A concrete form panel has a coating over its exterior face to make it moisture-resistant and nonadhesive to concrete when used as forming material. The exterior coating reduces the number of times the form must be oiled and allows the panel to be reused several times.

COMMON WOOD SUBSTITUTE

For various reasons, many common construction materials are used as wood or plywood substitutes. Some are significantly less expensive than plywood; others are more suitable because of their decorative appearance and weather-resistant qualities.

Particleboard

Particleboard, commonly referred to as chipboard or flakeboard, is produced by mixing a resin-bonding agent with wood particles and bonding them together by means of heat and pressure. The use of particleboard is limited to nonstructural use because of its low strength qualities. The most common size sheets are 4 ft by 8 ft and vary from 1/4 in. to 1 1/2 in. thick.

Hardboard

Hardboard is made of compressed wood fibers subjected to heat and heavy pressure. The finish may be obtained in a plain, smooth surface or in any number of glossy finishes, some of which imitate tile or stone. Its strength is about equal in all directions, and it can be bent into various shapes. Hardboard is available in thicknesses from 1/8 in. to 3/8 in. The most common size sheets are 4 ft by 8 ft.

Fiberboard

Fiberboard is made of wood or vegetable fiber that has been compressed to form sheets or boards. They are comparatively soft and provide good insulation and sound-absorbing qualities. Fiberboard is available in sizes from 1/2 in. to

1 in. thick, 2 ft to 4 ft wide, and 8 ft to 12 ft long.

Gypsum Wallboard

Gypsum wallboard is composed of gypsum between two layers of heavy paper. Some types have unfinished surfaces, while others have finishes that represent wood grain or tile. The most common thickness is 1/2 in. Its width is usually 4 ft, and its length varies from 4 to 14 ft.

Another type of gypsum wallboard has depressed or tapered edges. The joints are filled with special cement and are then taped so that the joints do not show. They can then be painted. This procedure is commonly known as DRY WALL. Dry walls are particularly useful in areas and spaces where sound-deadening and fire-resistant materials are desired.

TREATMENT

When not properly treated and installed, wood can be destroyed by decay, fungi, boring insects, weathering, or fire. Although designed for the specific use of the wood, treatment varies from project to project and from one geographical area to another. The kind and amount of treatment is usually given by the project specifications. Where no written specifications exist, the drawings should indicate the kind and amount of wood treatment.

Manufacturers' commercial standards contain information on wood pretreated by the manufacturer. NAVFAC publications and specifications provide technical information and design requirements for the treatment of wood used in buildings and structures.

WOOD FRAME STRUCTURES

In a wood frame building or structure, the framework consists mostly of wood load-bearing members that are joined together to form an internal supporting structure, much like the skeleton of a human body.

When a complete set of drawings is made for a certain building, large-scale details are usually shown for typical sections, joints, and other unusual construction features. Understanding the different functions of the structural members of a frame building will enable you to make these drawings correctly and promptly.

THEORY OF FRAMING

Generally, a building has two main parts: the FOUNDATION and that part above the foundation, called the SUPERSTRUCTURE. The

framework of a wooden superstructure is called the FRAMING of the building. It is subdivided into floor framing, wall framing, and roof framing. FLOOR FRAMING consists, for the most part, of horizontal structural members called joists, and the WALL FRAMING, for the most part, of vertical members called studs. ROOF

FRAMING consists of both horizontal and vertical structural members.

The most common framing and construction methods are the PLATFORM (also called WESTERN and STORY-BY-STORY framing) (fig. 6-9) and the BALLOON FRAMING (fig. 6-10). The striking difference between these two methods is

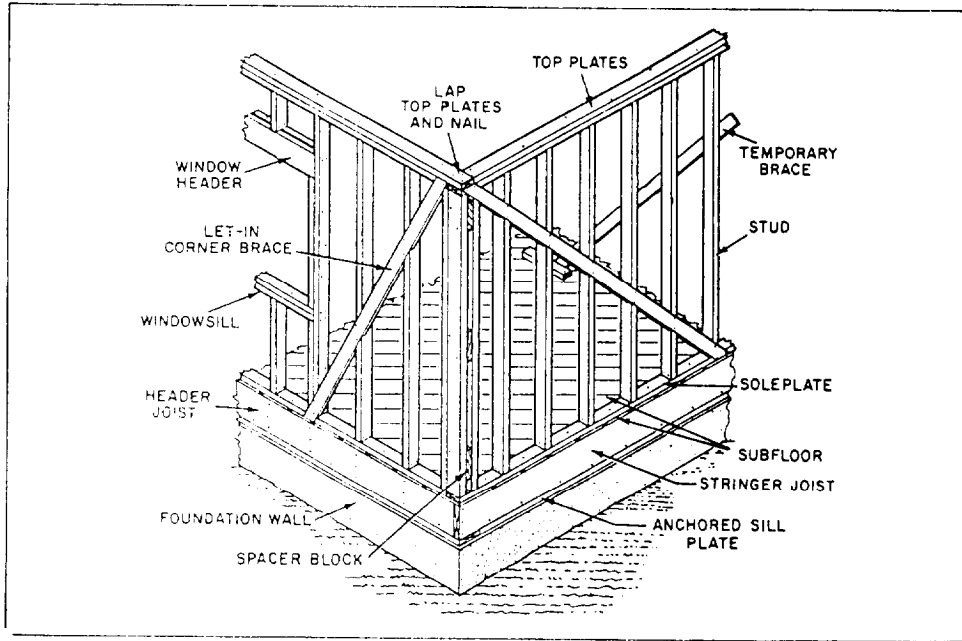

Figure 6-9.-Wall framing used in platform construction.

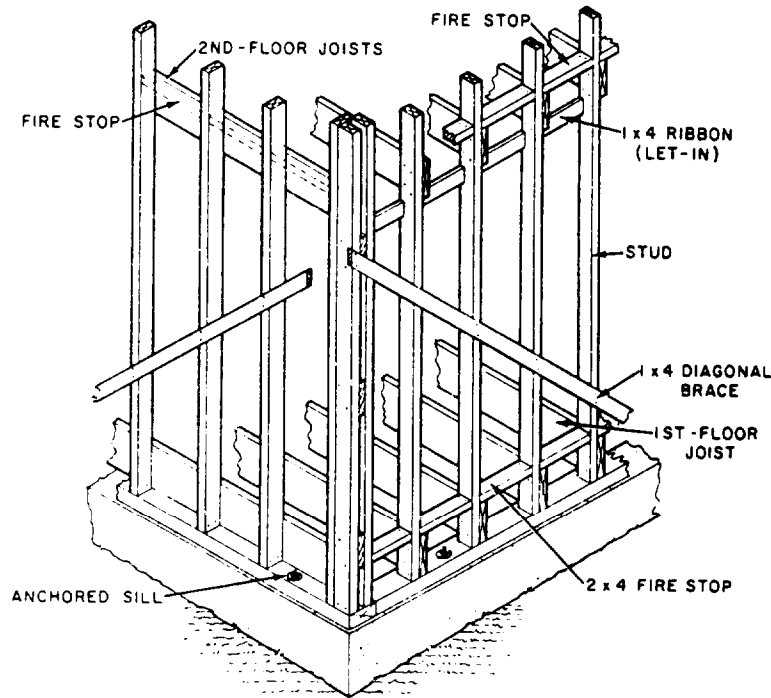

Figure 6-10.-Wall framing used in balloon construction.

that in balloon framing, the studs extend from the sill of the first floor to the top of the soleplate or end rafter of the second floor; whereas the platform framing has separate studs for each floor anchored on the soleplate.

SILL FRAMING AND LAYOUT

The lowest horizontal wood frame structural member is the SILL, a piece of dimensional

lumber laid flat and bolted down to the top of the foundation pier or wall. It is the first part of the frame to be set in place and provides a nailing base for the other adjoining members. It may extend all around the building, joined at the corners and spliced when necessary.

The type of sill assembly selected depends upon the general type of construction methods used in the framework. The method of framing

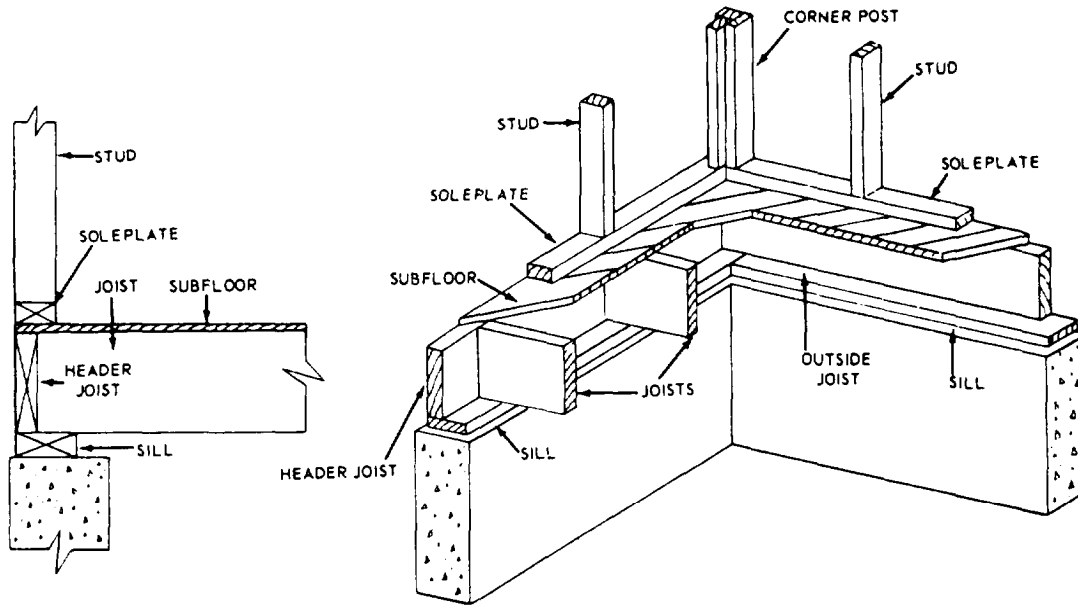

Figure 6-11.-Box-sill assembly for platform framing.

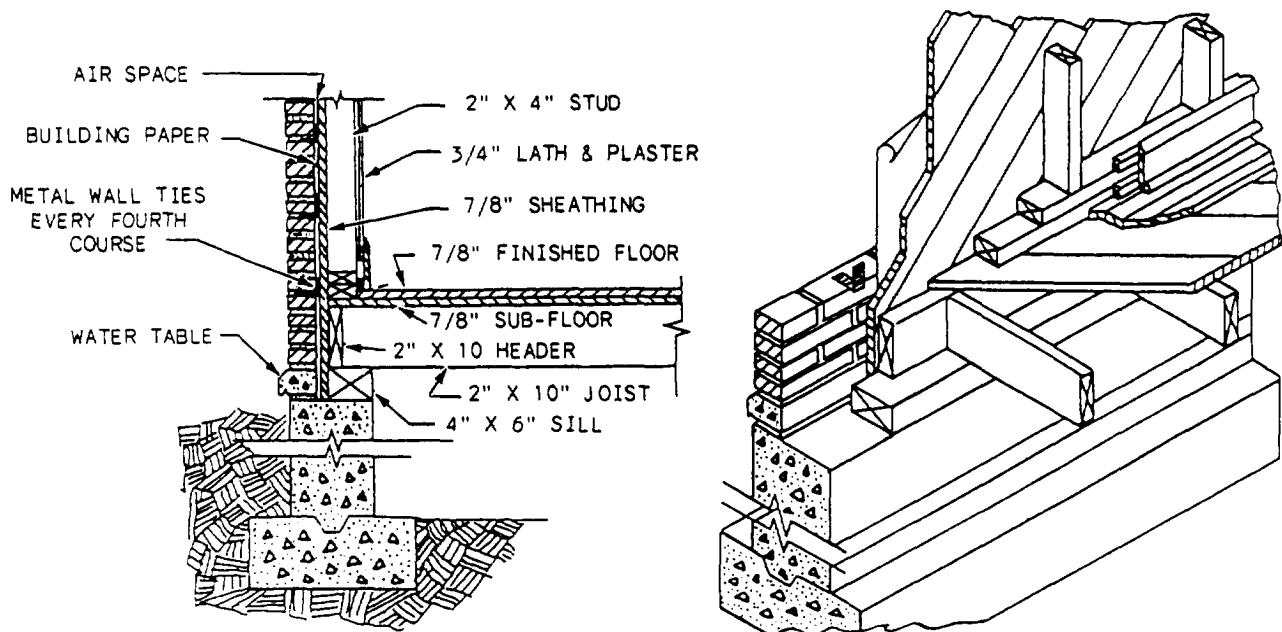

Figure 6-12.-Sill assembly in brick veneer construction.

the studs to the sill is called SILL ASSEMBLY. The BOX-SILL assembly shown in figure 6-11 is the type most frequently used in platform-frame construction. In this type, the ends of the joists are framed against a header-joist, which is set flush with the outer edge of the sill. The construction method for a sill assembly in which brick veneer is used as exterior siding (fig. 6-12) is similar to the box-sill assembly except that the

sill is set in the foundation wall to allow enough space for the brick to rest directly on the wall.

Balloon-frame construction uses the T-SILL (fig. 6-13) and EASTERN (fig. 6-14) assemblies. Here, the studs are anchored on the sill and are continuous; that is, in one piece from sill to roof line.

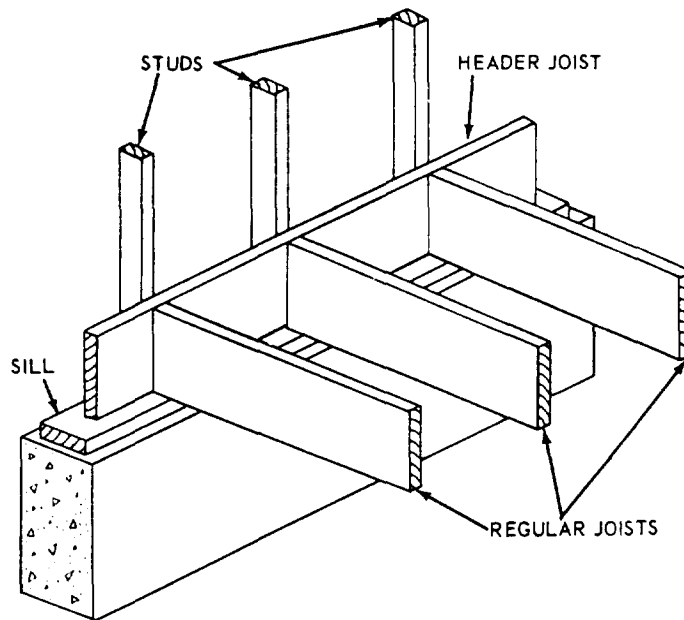
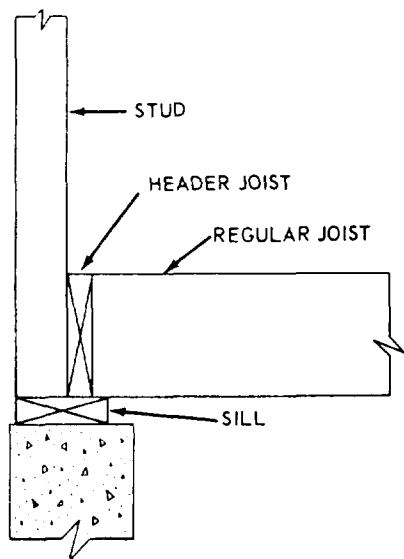

Figure 6-13-T-sill assembly.

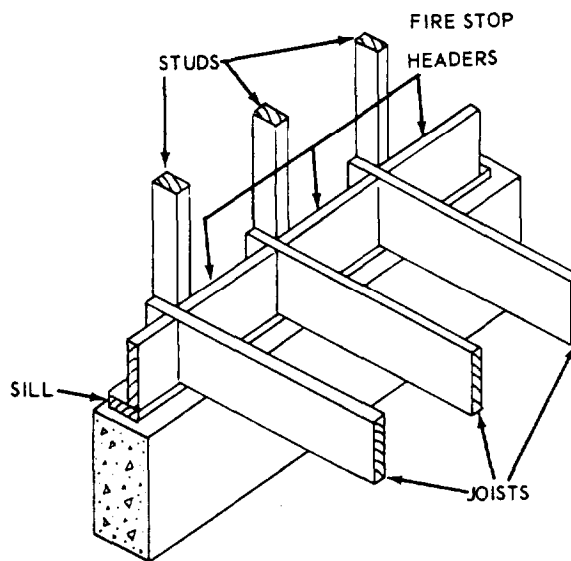
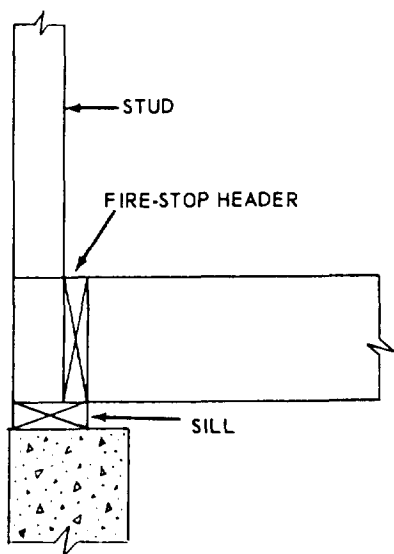

Figure 6-14.-Eastern sill assembly.

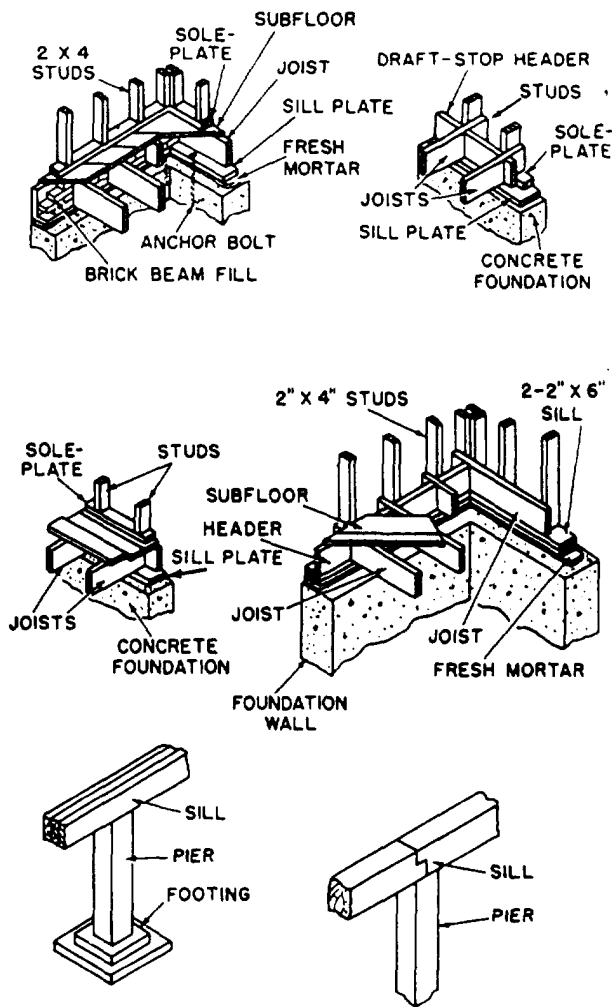

Figure 6-15.-Types of sills.

Other types of sill framing and layout are shown in figure 6-15.

FLOOR FRAMING

Horizontal members that support the floors in wood frame structures are called JOISTS or BEAMS, depending upon the length of the SPAN (distance between the end supports). Members less than 4 ft apart are called joists; members 4 ft or more apart are called beams. The usual spacing for wood frame floor members is either 16 in. or 24 in. O.C. Joists are usually 2 by 8, 2 by 10, or 2 by 12. A COMMON JOIST is a full-length joist that spans from wall to wall or from wall to girder. A CRIPPLE JOIST is similar to a common joist with the exception that it does not

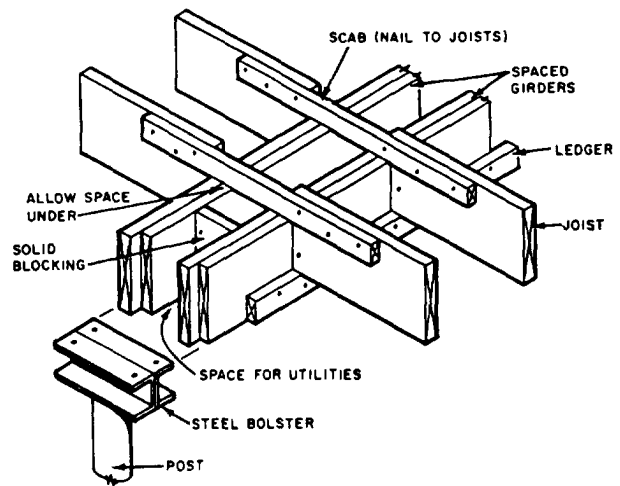

Figure 6-16.-Spaced wood girder.

extend the full span. Cripples are normally interrupted by floor openings.

Girders (fig. 6-16) are horizontal members that support joists at points other than along the outer wall lines. When the span is longer than can be covered by a single joist, a girder must be placed as an intermediate support for joist ends. Ground-floor girders are commonly supported by concrete or masonry pillars and pilasters. A PILLAR is a girder support that is clear of the foundation walls. A PILASTER is set against a foundation wall and supports the end of a girder. Both pillars and pilasters are themselves supported by concrete footings. Upper-floor girders are supported by columns. GIRTS are horizontal wood framing members that help to support the outer-wall ends of upper-floor joists in balloon framing.

Framing Around Floor Openings

A common joist must be cut away to give way for floor openings, such as stairways. The wall-opening ends of cripple joists are framed against HEADERS, as shown in figure 6-17. Specifications usually require that headers be doubled—sometimes tripled. Headers are framed between the full-length joists, also called TRIMMERS, on either side of the floor opening. Headers up to 6 ft in length are fastened with nails, whereas those longer than 6 ft are fastened with joist hangers.

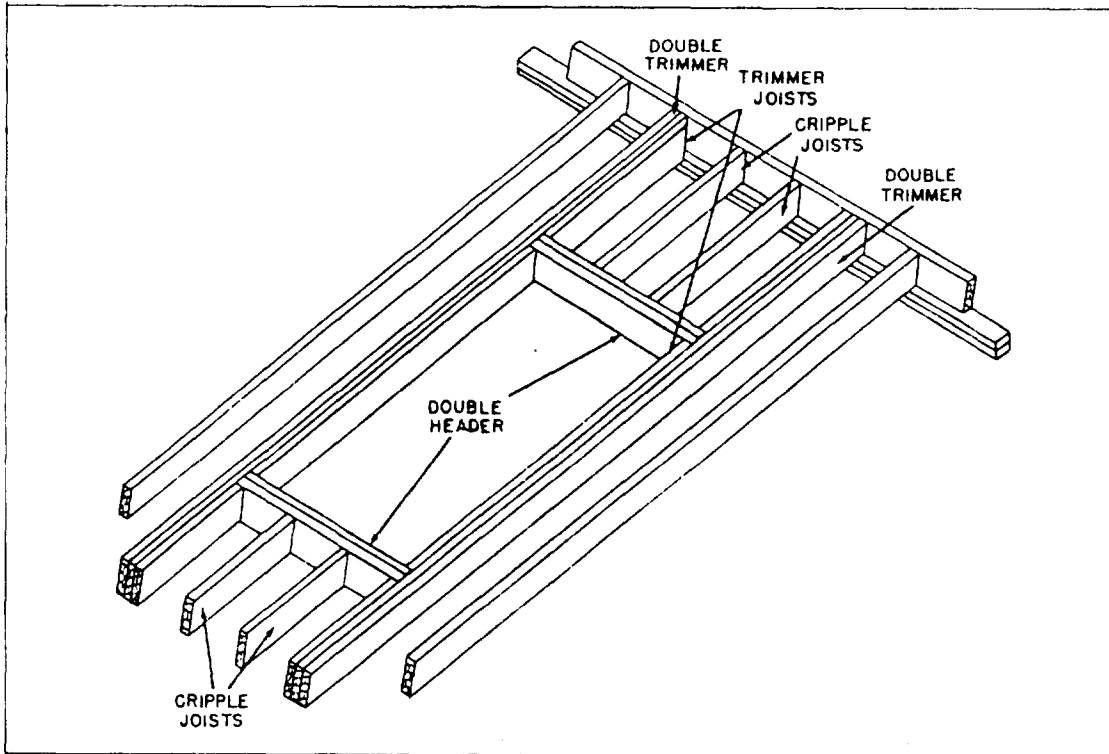

Figure 6-17.-Framing around floor openings.

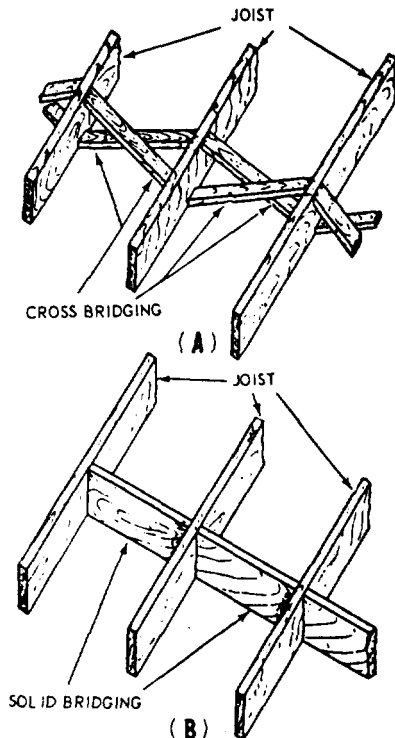

Figure 6-18.-Cross bridging and solid bridging.

Bridging

Bridging is the system of bracing the joists to each other to hold them plumb and aligned. It also serves to distribute part of a concentrated load over several joists next to those directly under the load. There are two types of bridging: CROSS BRIDGING (fig. 6-18, view A) and SOLID BRIDGING (fig. 6-18, view B). Cross bridging consists of pairs of STRUTS set diagonally between the joists. The strut stock comes in sizes of 1 by 3, 1 by 4, 2 by 2, and 2 by 4. Solid bridging consists of pieces of joist-size stock set at right angles to the joists. They can be staggered for easier installation. Cross bridging is more rigid than solid bridging and is more frequently used in construction. Bridging should be provided for all spans greater than 6 ft.

Subflooring

Joists are covered by a layer (or double layer) of boards called SUBFLOORING. It usually consists of square-edge or tongue-and-grooved boards or plywood 1/2 to 3/4 in. thick that serve

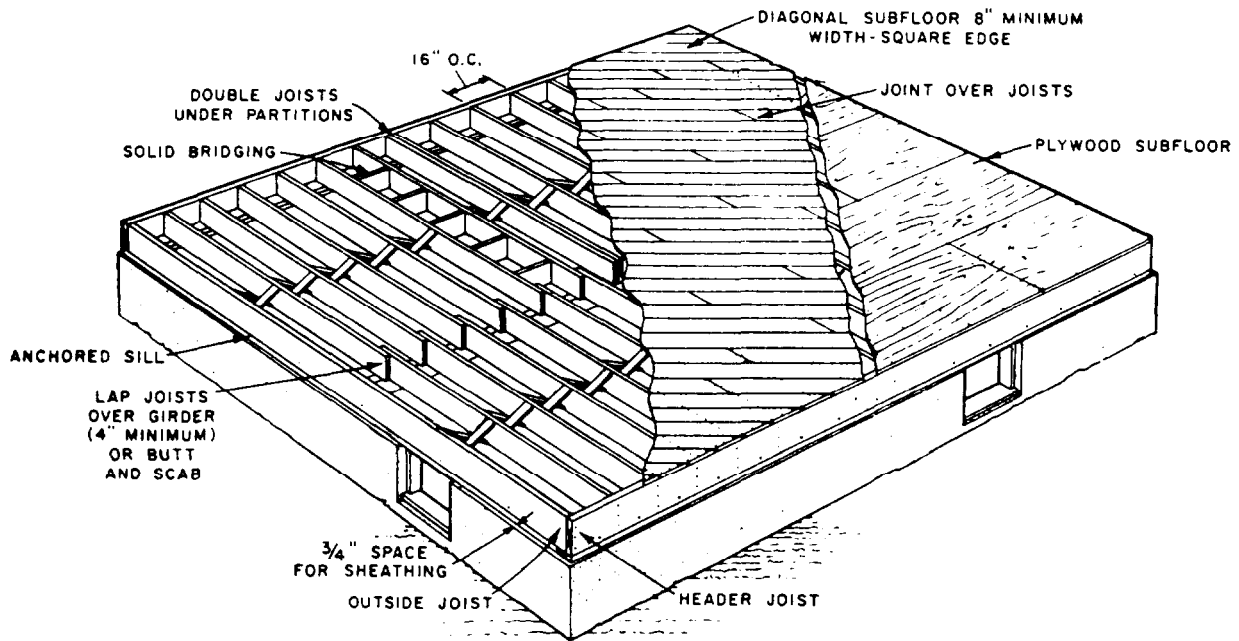

Figure 6-19.-Typical floor framing with subflooring.

as a working platform and base for finish flooring (fig. 6-19). Sub flooring may be applied either diagonally (most common) or at right angles to the joists. Diagonal subflooring permits finish flooring to be laid either parallel to, or, more commonly, at right angles to, the joists. The joist spacing should not exceed 16 in. O.C. when finish flooring is laid parallel to the joists or when parquet finish flooring is used.

WALL FRAMING

As with floor construction, two general types of wall framing are commonly used: platform construction and balloon-frame construction. The platform method shown in figure 6-9 is more often used because of its simplicity.

A typical wall frame (fig. 6-20) is composed of regular studs, cripples, trimmers, headers, and fire stops (fig. 6-10) and is supported by the floor soleplate. The wall framing members used in conventional construction are generally nominal 2 by 4 in. in size. The requirements are good stiffness, good nail-holding ability, freedom from warp, reasonable dryness (about 15-percent moisture content), and ease of working. The closely spaced and slender vertical members of the wall framing are called the **STUDS**. They support the top plates and provide the framework to which the wall sheathing is nailed on the outside and

which supports the lath, plaster, and insulation on the inside. **TOP PLATES** (or **CAPS**) are horizontal wood framing members that are nailed to the tops of the wall or partition studs. **SOLEPLATES** are horizontal wood framing members that serve as nailing bases for studs in platform-framing construction. **HEADERS** form the upper members of a rough doorframe, or upper or lower members of a rough window frame. Similar members that form the ends of a rough floor or roof opening (as a skylight) are also called headers.

Partition

The inside space of a building is divided by partition walls. In most cases, these walls are framed as part of the building. There are two types of partition walls: **BEARING** and **NONBEARING**. Partition walls of the bearing type support the ceiling joists and all other loads imposed upon them; those of the nonbearing type support only themselves and are usually installed after the other framework is put in. Partition walls are framed in the same manner as outside walls, and door openings are framed as outside openings. **CORNER POSTS** or **T-POSTS** are used at corners or where one partition wall joins another. They provide nailing surfaces for the inside wall finish (fig. 6-21).

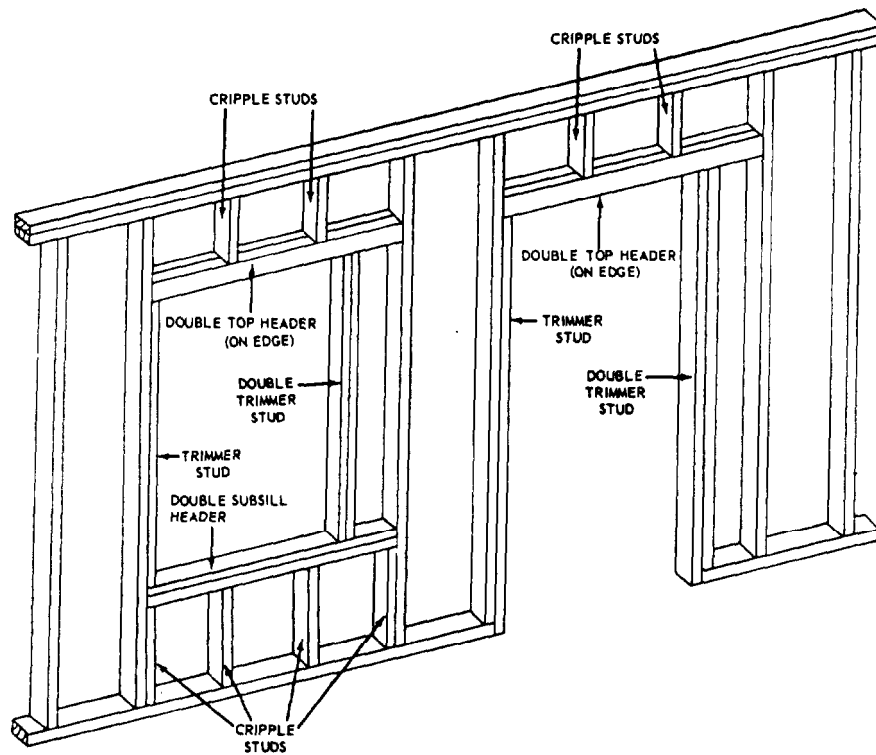

Figure 6-20.-Parts of a wall frame, showing headers.

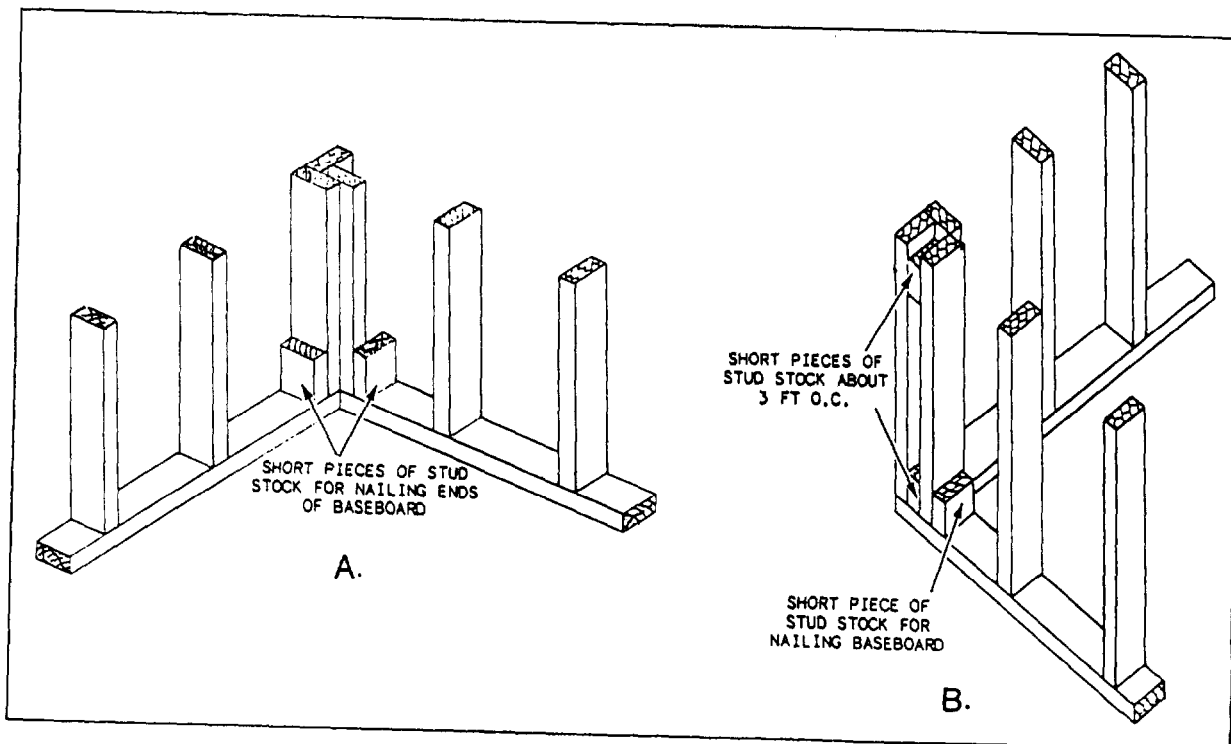

Figure 6-21.-Typical examples of corner posts: A. Simplest type; B. More solid type.

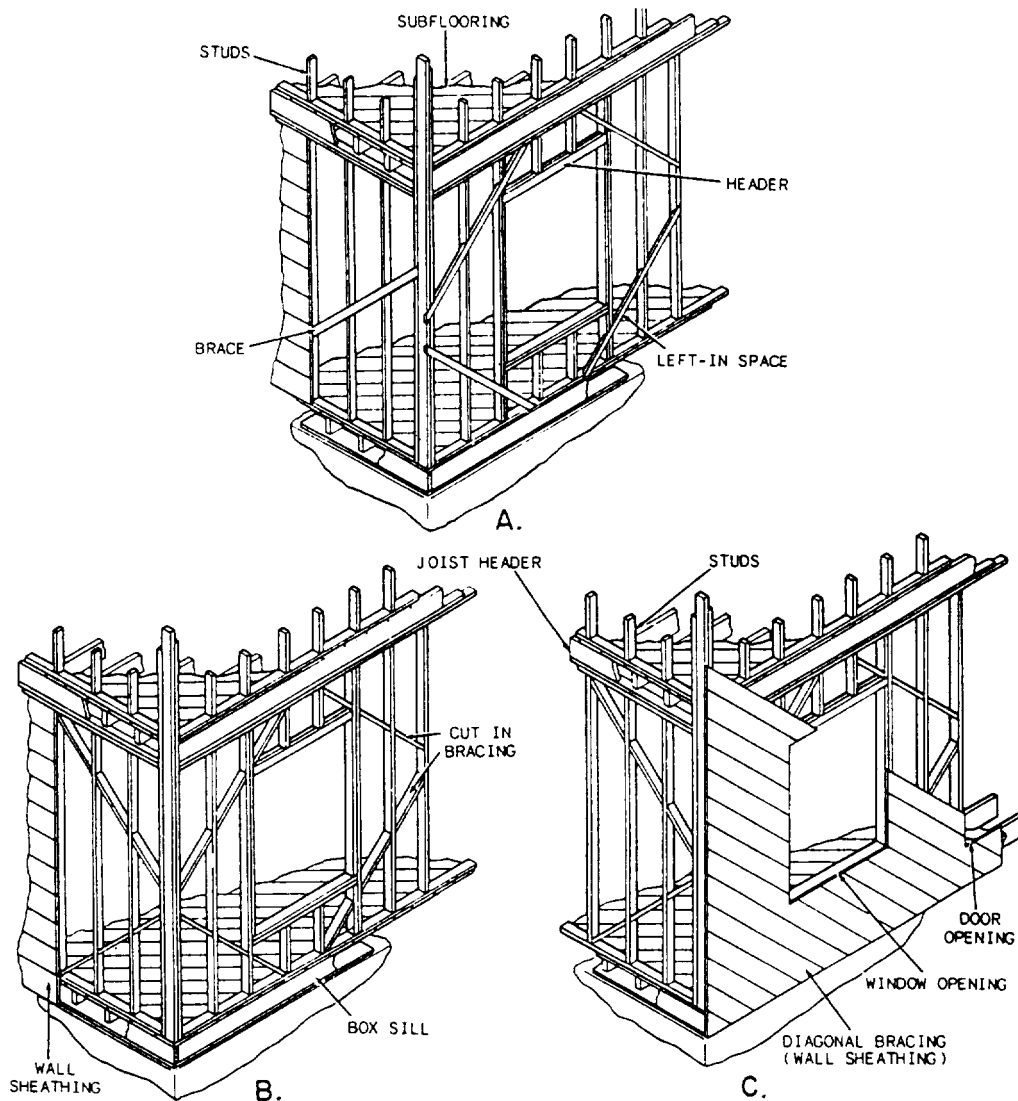

Figure 6-22.-Common types of bracing: A. Let-in bracing; B. Cut-in bracing; C. Diagonal bracing.

Braces

Braces are used to stiffen framed construction and help buildings resist the twisting or straining effects of wind or storm. Good bracing keeps corners square and plumb and prevents warping, sagging, and shifts resulting from lateral and external forces that would otherwise tend to distort the frame. Figure 6-22 shows three common methods of bracing frame structures: (A) let-in bracing, (B) cut-in bracing, and (C) diagonal bracing.

ROOF FRAMING

Roofs must be sloped so that they will shed water. The most common types of roof

construction include the intersecting, the shed, the gable, and the hip (fig. 6-23). An INTERSECTING ROOF consists of a gable and valley or hip and valley intersecting each other at right angles. A SHED ROOF has a single surface that slopes downward from a ridge on one side of the structure. A GABLE ROOF has two surfaces sloping downward from a ridge located between the sides of the structure—usually midway between them. A HIP ROOF is pitched on the sides like a gable roof and also is pitched on one or both ends.

Roof Pitch

The PITCH (amount of slope) of a roof is expressed as a FRACTION in which the

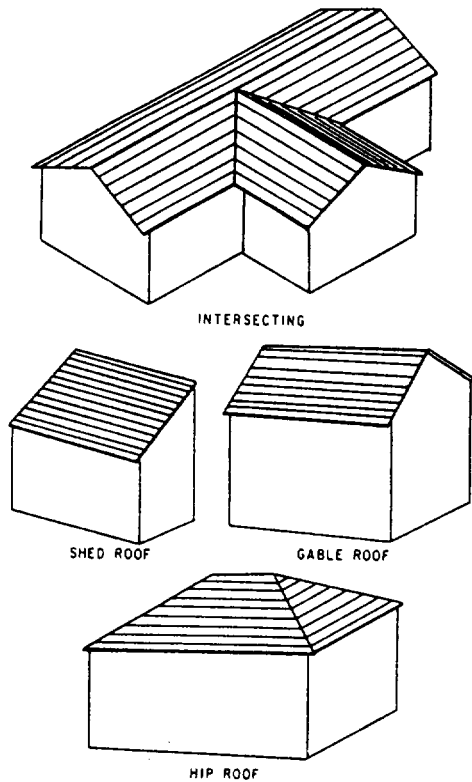

Figure 6-23.-Most common types of pitched roofs.

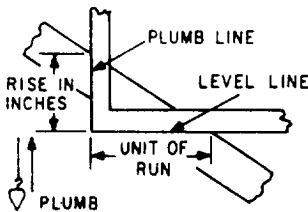
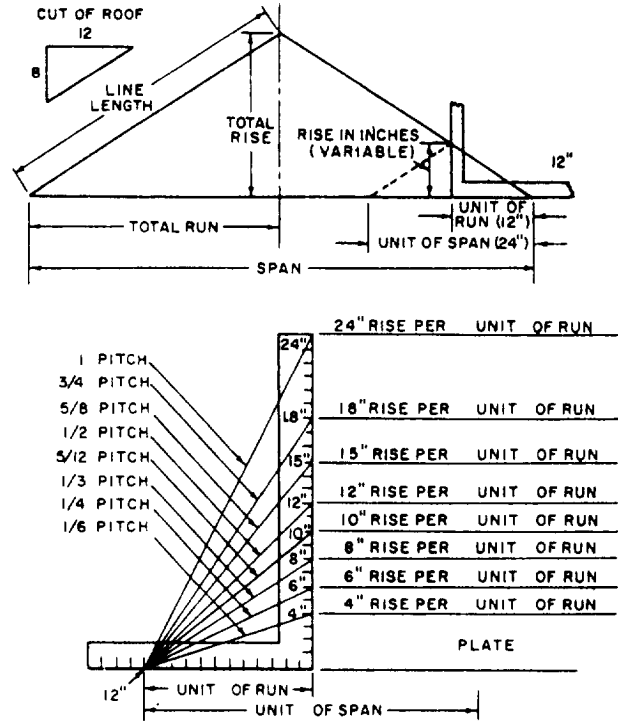

Figure 6-24.-Roof pitch diagram.

numerator is the UNIT RISE and the denominator is the UNIT SPAN. By common practice, unit run is always given as 12. See the roof pitch diagram in figure 6-24. Expressed in equation form,

$$\text{Pitch} = \frac{\text{Unit Rise}}{\text{Unit Span}}$$

$$= \frac{\text{Unit Rise}}{2 \times \text{Unit Run}}$$

Suppose that a roof rises 8 units for every 12 units of run—meaning that unit rise is 8 and unit run is 12. Since the unit span is 24, the pitch of the roof is 8/24, or 1/3. This value is also indicated in the center view of the roof pitch diagram in figure 6-24.

On construction drawings, the pitch of a roof is indicated by a small ROOF TRIANGLE like the one in the upper view of figure 6-24. The triangle is drawn to scale so that the length of the horizontal side equals the unit run (which is always 12), and the length of the vertical side equals the unit rise.

Rafter Layout

RAFTERS are framing members that support a roof. They do for the roof what joists do for the floor and what the studs do for the wall. They are generally inclined members spaced from 16 to 48 in, apart that vary in size, depending on their length and the distance they are spaced.

The tops of the inclined rafters are fastened in one of the various common ways, which is determined by the type of roof. The bottoms of the rafters rest on the plate member, which provides a connecting link between the wall and the roof and is really a functional part of both.

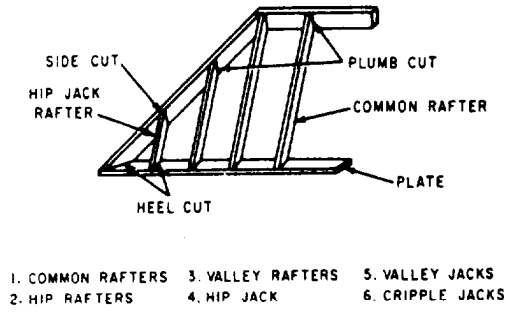
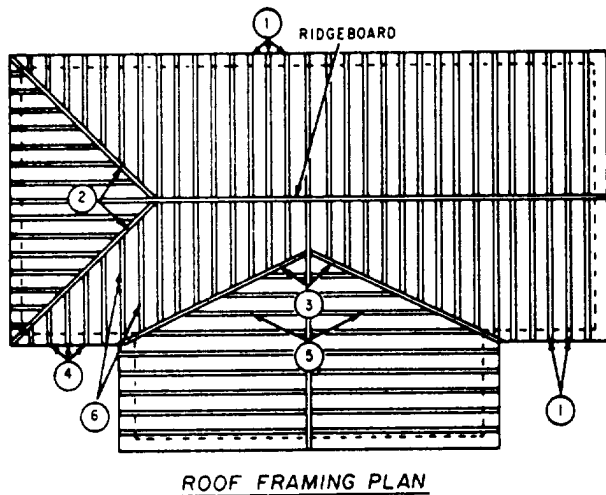

Figure 6-25.-Rafter terms.

The structural relationship between the rafters and the wall is the same in all types of roofs. The rafters are NOT framed into the plate, but simply nailed to it. Some are cut to fit the plate. In hasty construction, rafters are merely laid on top of the plate and nailed in place. Rafters may extend a short distance beyond the wall to form the eaves and protect the sides of the building.

Figure 6-25 shows a typical roof framing plan. The following rafter terms and definitions supplement the notes in the drawing:

COMMON RAFTERS—Rafters that extend from the plates to the ridgeboard at right angles to both.

HIP RAFTERS—Rafters that extend diagonally from the corners formed by perpendicular plates to the ridgeboard.

VALLEY RAFTERS—Rafters that extend from the plates to the ridgeboard along the lines where two roofs intersect.

HIP JACKS—Rafters whose lower ends rest on the plate and whose upper ends rest against the hip rafter.

VALLEY JACKS—Rafters whose lower ends rest against the valley rafters and whose upper ends rest against the ridgeboard.

CRIPPLE JACKS—Rafters that are nailed between hip and valley rafters.

JACK RAFTERS—Hip jacks, valley jacks, or cripple jacks.

TOP OR PLUMB CUT—The cut made at the end of the rafter to be placed against the

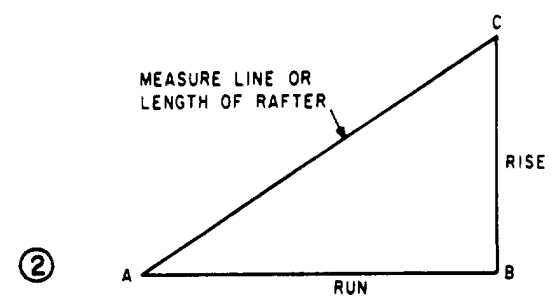
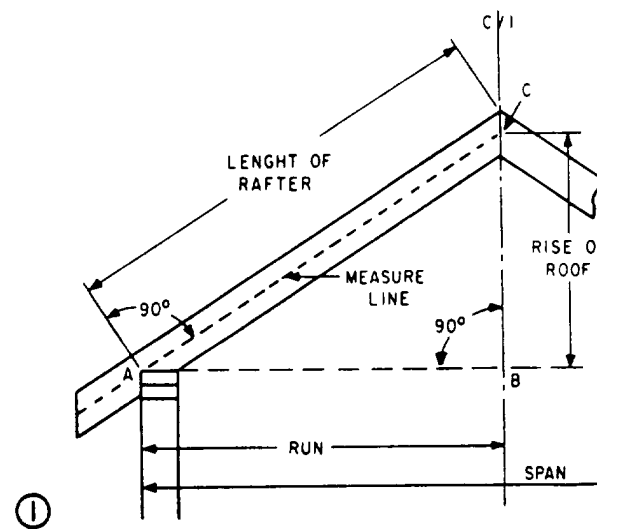

Figure 6-26.-Additional terms used in rafter layout.

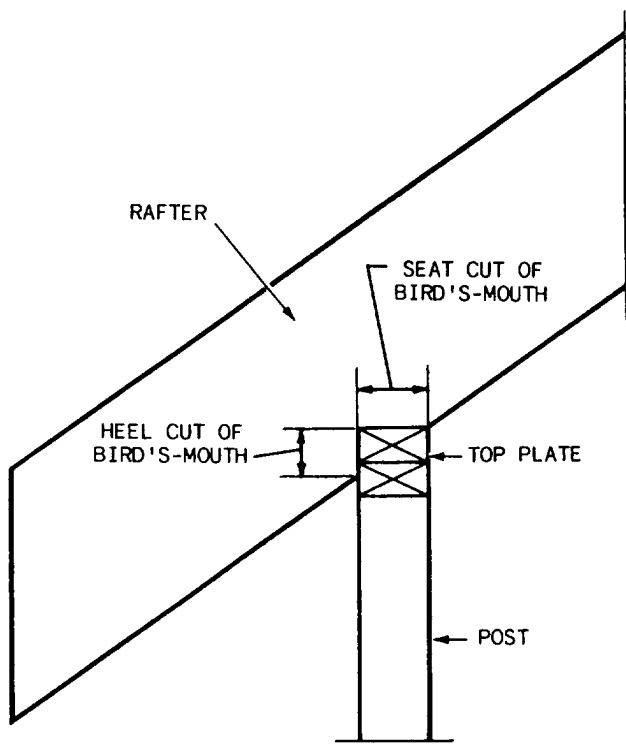

Figure 6-27.-Bird's-mouth on a rafter with projection.

ridgeboard or, if the ridgeboard is omitted, against the opposite rafters (fig. 6-25).

SEAT, BOTTOM, OR HEEL CUT—The cut made at the end of the rafter that is to rest on the plate.

SIDE, OR CHEEK, CUT—A bevel cut on the side of a rafter to fit against another frame member.

EAVE OR TAIL—The portion of the rafter extending beyond the outer edge of the plate.

Figure 6-26 shows additional terms used in connection with rafter layout.

RAFTER LENGTH is the shortest distance between the outer edge of the plate and the center of the ridgeline.

MEASURE LINE is an imaginary reference line laid out down the middle face of the rafter.

PLUMB LINE is any line that is vertical when the rafter is in its proper position.

LEVEL LINE is any line that is horizontal when the rafter is in its proper position.

A rafter with a projection often has a notch in it called a **BIRD'S-MOUTH** (fig. 6-27). The plumb cut of the bird's-mouth that bears against the side of the rafter plate is called the **HEEL CUT**, whereas the **SEAT CUT** bears on top of the bird's-mouth. **COLLAR TIES** (fig. 6-28) are horizontal members used as reinforcement in gable or double-pitch roof rafters. In a finished attic, these ties may function as ceiling joists.

When the rafters are placed farther apart, horizontal members called **PURLINS** are placed across them to serve as the nailing or connecting members for the roofing. Purlins are generally used with standard metal roofing sheets, such as galvanized iron or aluminum sheets.

Several methods of roof framing and types of rafter arrangement are further shown in figures 6-29 through 6-36.

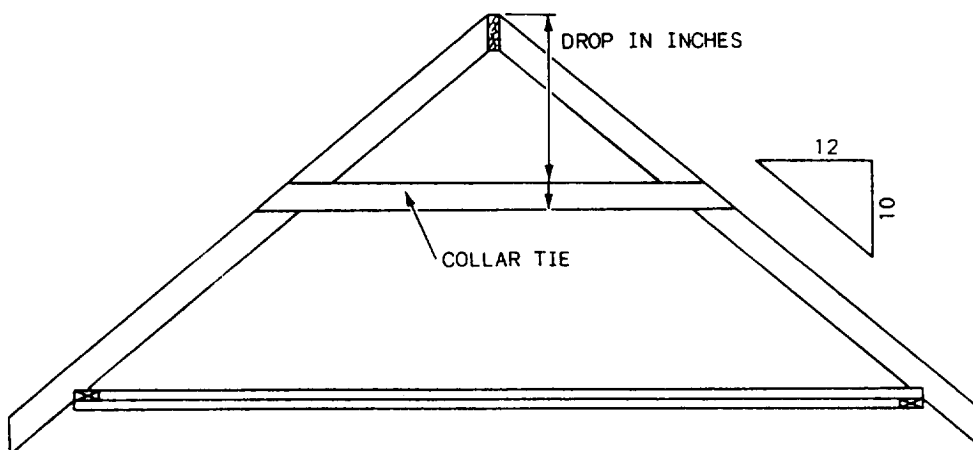

Figure 6-28.-Layout of a collar tie.

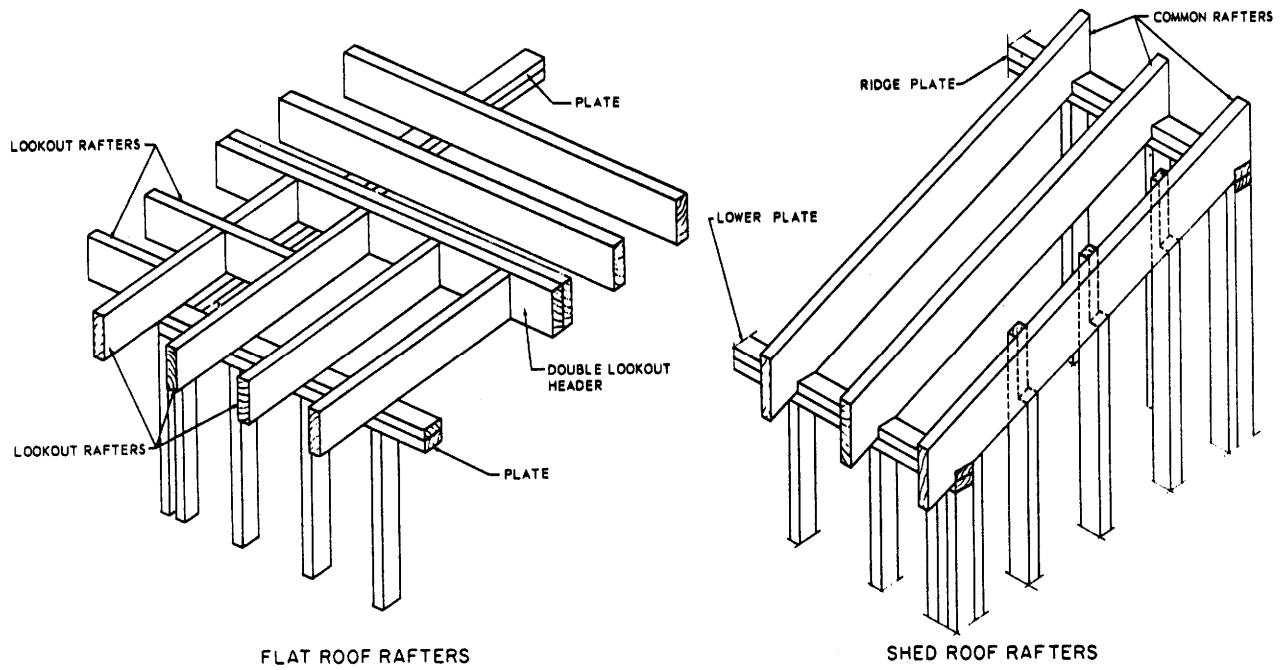

Figure 6-29.—Flat and shed roof framings.

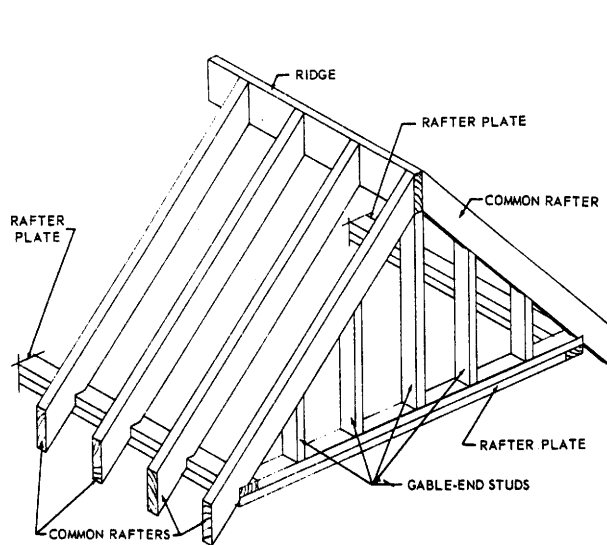

Figure 6-30.—Gable roof framing.

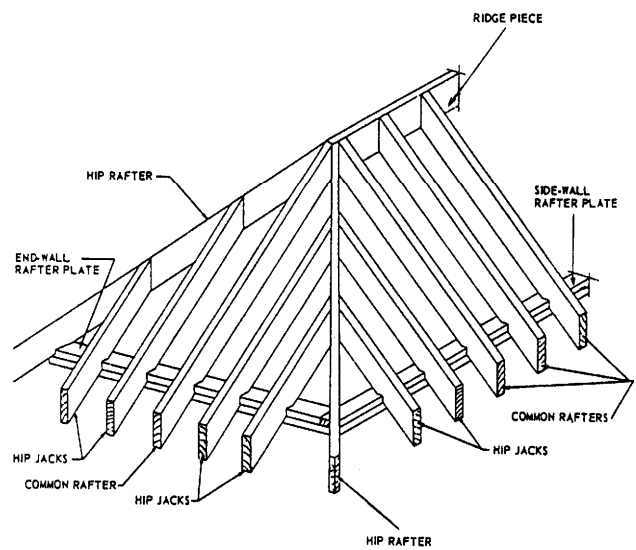

Figure 6-31.—Equal-pitch roof

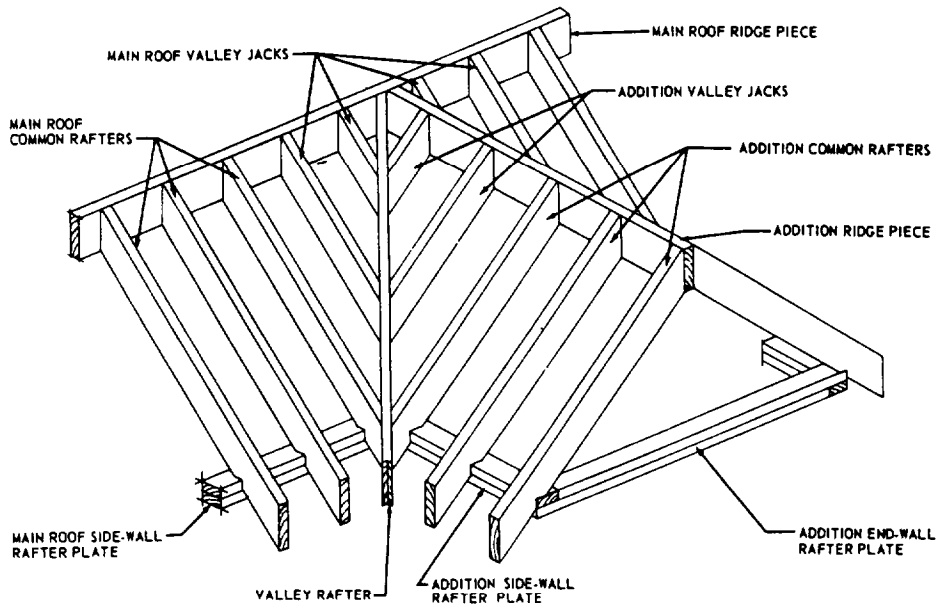

Figure 6-32.-Addition roof framing.

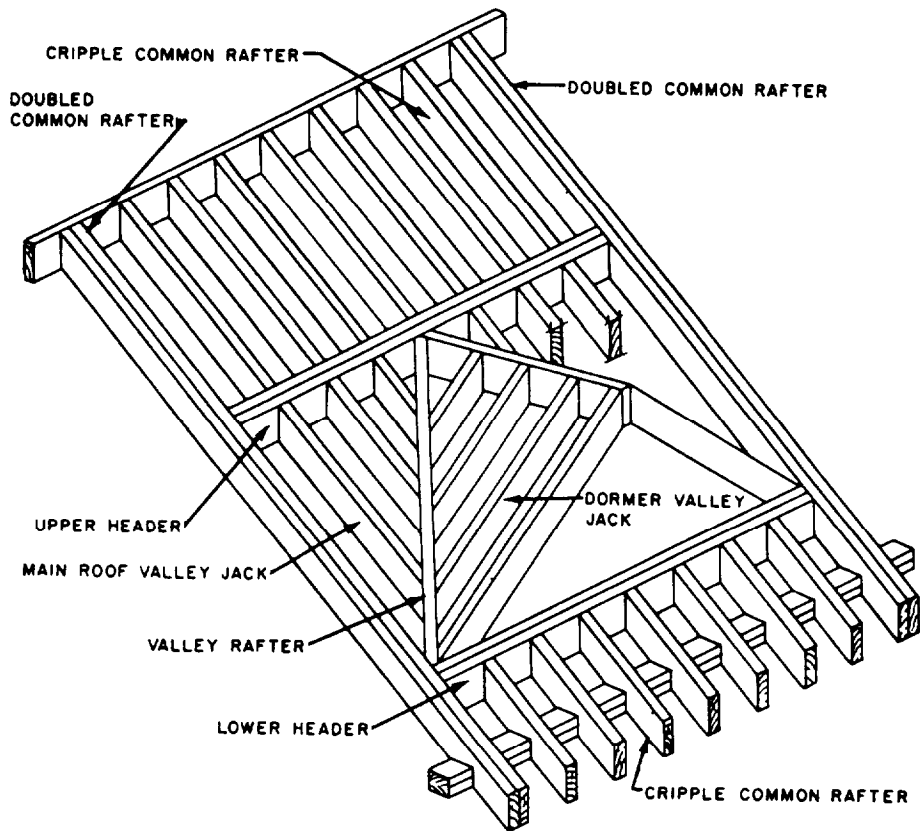

Figure 6-33.-Framing of gable dormer without sidewalls.

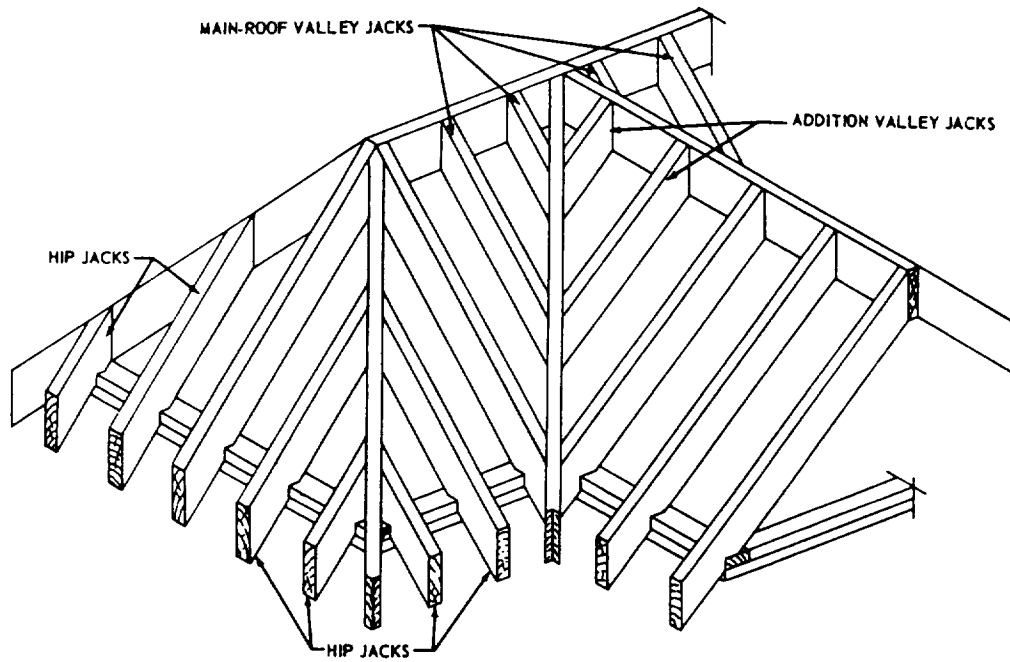

Figure 6-34.-Types of jack rafters.

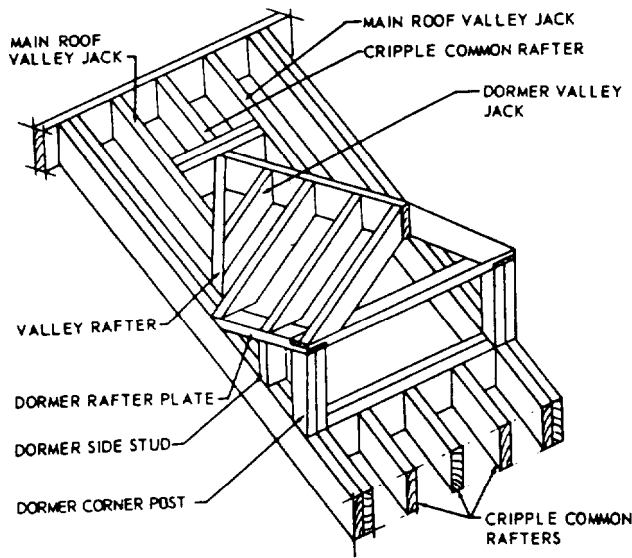

Figure 6-35.-Framing of gable dormer with sidewalls.

Roof Trusses

A TRUSS is an engineered structural frame that is used to span distances that are too great for single-piece members without intermediate supports. Figure 6-37 shows a roof truss or rafter truss assembly. Chords and webs are connected to one another by GUSSET PLATES—metal

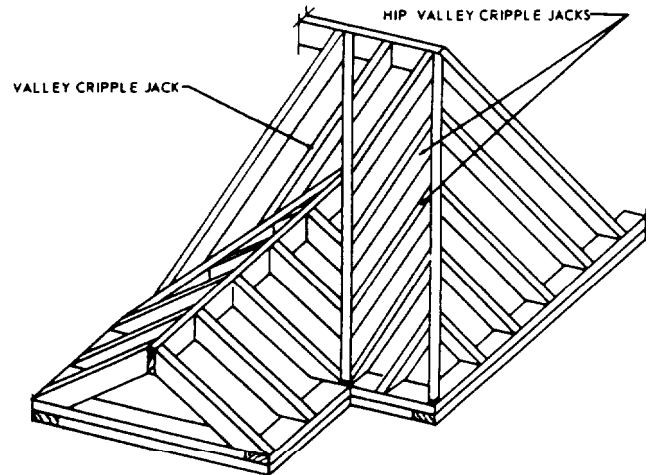

Figure 6-36.-Cripple jacks.

plates or plywood pieces that are nailed, glued, or bolted in place. The load that the roof must carry is the important factor to be considered in selecting the type of truss. These loads may consist of the roof itself, forces caused by wind, and the weight of snowfall or ice.

Some of the most common types of light wood trusses are shown in figure 6-38. The W-truss (fig. 6-38, view A) is perhaps the most widely used. It uses four web members assembled in the

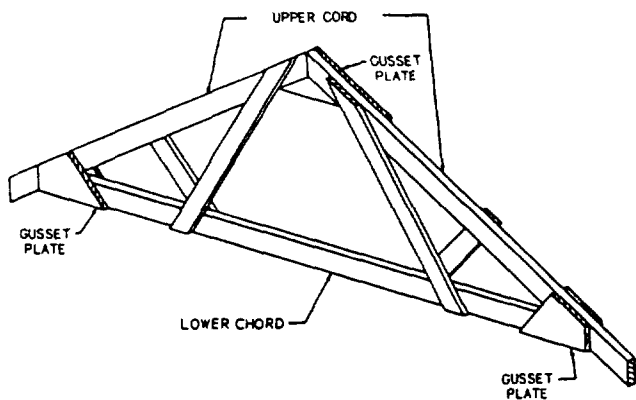

Figure 6-37-Roof or rafter truss.

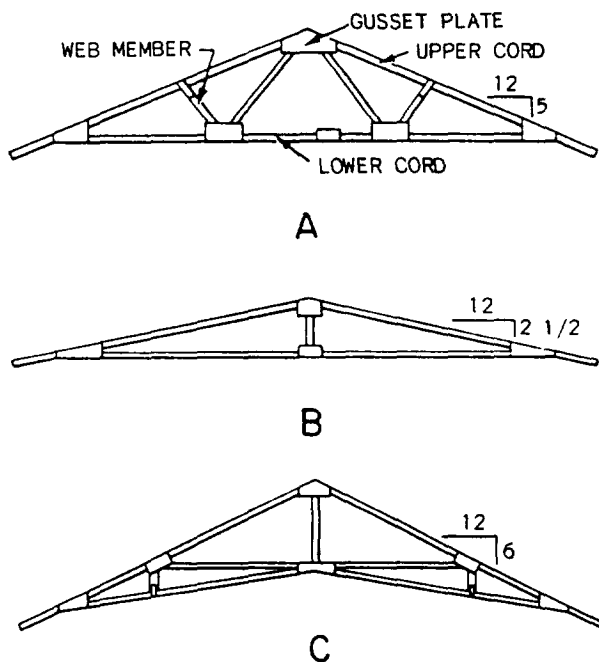

Figure 6-38.-Light wood trusses: A. W-type; B. King post; C. Scissors.

shape of the letter *W* instead of a center post. The *KING POST* truss is the simplest type of structure. It consists of an upper and lower chord with a vertical center post (fig. 6-38, view B). The *SCISSORS* truss (fig. 6-38, view C) is used for structures with sloped ceiling room, such as a vaulted ceiling.

BUILDING FINISH

Perhaps the best way to define building finish is to say that it comprises those nonstructural parts

of the building. The finish is divided into *EXTERIOR* finish (located principally on the outside of the structure) and *INTERIOR* finish (located inside). The work involved in the installation of nonstructural members on the structure is called *FINISH CARPENTRY*.

EXTERIOR FINISH

The principal items of the exterior finish are the *ROOF SHEATHING* and *COVERING*, *EXTERIOR TRIM*, and *WALL SHEATHING*. The order in which these items are erected may vary slightly, although in some cases two or more items may be installed at the same time. Normally, roof sheathing is installed as soon as possible to allow work inside a structure to progress during inclement weather.

Roof Sheathing and Roof Covering

Roof sheathing is the covering over the rafters or trusses and usually consists of nominal 1-in. lumber or plywood. In some types of flat or low-pitched roofs, wood roof planking or fiberboard roof decking might be used. Sheathing should be thick enough to span the supports and provide a solid base for fastening the roofing materials. Generally, third grade species of lumber, such as pines, redwoods, and hemlocks, are used as roof sheathing boards.

Board roof sheathing (fig. 6-39) used under asphalt shingles, metal sheet roofing, or other

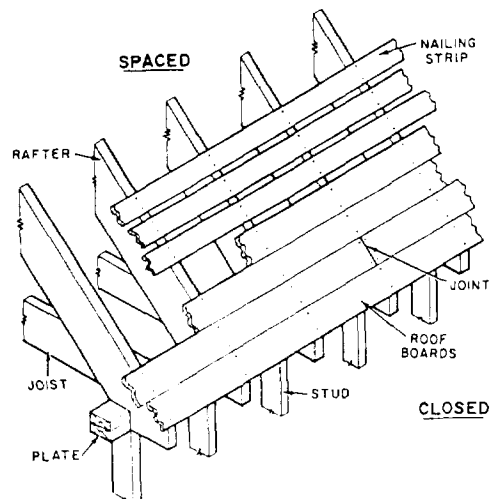

Figure 6-39.-Typical board roof sheathing, showing both closed and spaced types.

roofing materials that require continuous support should be laid closed (without spacing); however, when wood shingles or shakes are used in damp climates, it is common to have spaced roof boards (fig. 6-39). When plywood roof sheathing is used, it should be laid with the grain perpendicular to the rafter (fig. 6-40).

Roof covering materials used for pitched roofs are wood, asphalt shingles, tiles and slate, galvanized iron (GI) sheets, and several other sheet materials. For flat or low-pitched roofs, a built-up construction is also used. An asphalt-saturated felt underpayment called ROOFING FELT is applied over the roof sheathing before the roof covering is installed. The roofing felt serves three basic purposes: It keeps the roof sheathing dry until the shingles can be applied, it acts as a secondary barrier against wind-driven rain and snow, and it protects the shingles from any resinous substance that may be released from the sheathing.

The method of laying an asphalt-shingle roof is shown in figure 6-41. The roofing rolls are usually 36 in. wide with a 2 in. to 4 in. overlap. The shingles are usually laid with 5 in. exposed to the weather. Figure 6-42 shows installation of wood shingles. Wood shingles are available in

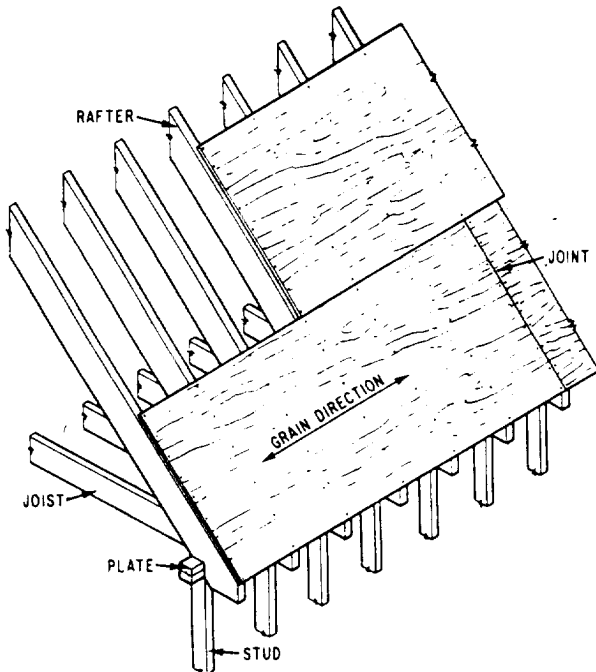

Figure 6-40.-Application of plywood roof sheathing.

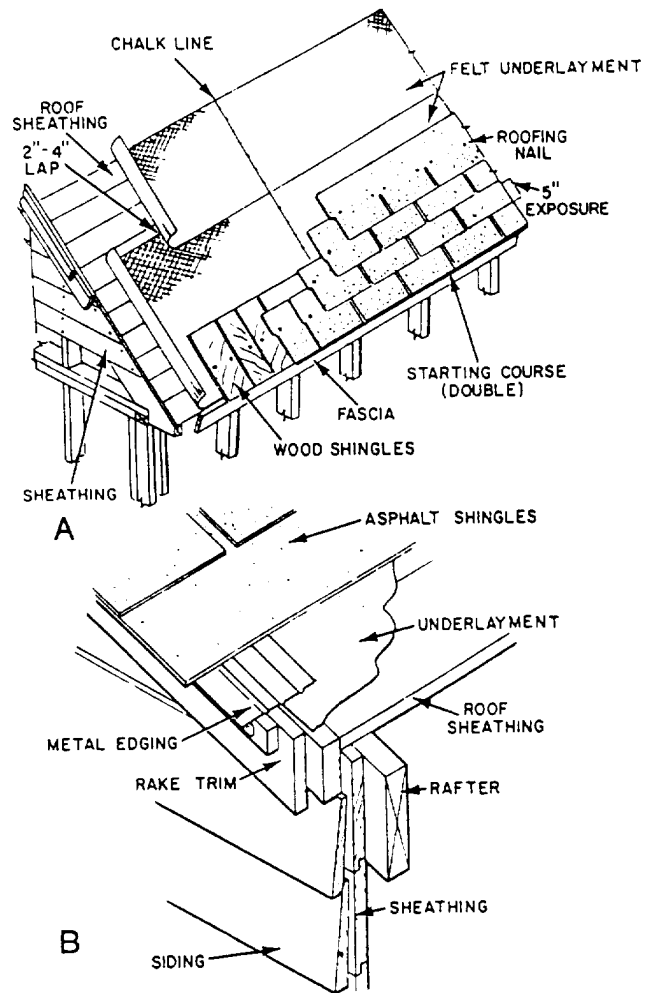

Figure 6-41.-Application of asphalt shingles: A. Common method with strip shingles; B. Metal edging at gable end.

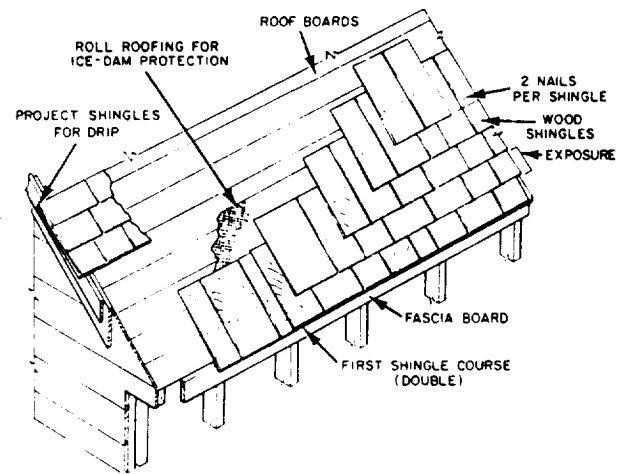

Figure 6-42.-Installation of wood shingles.

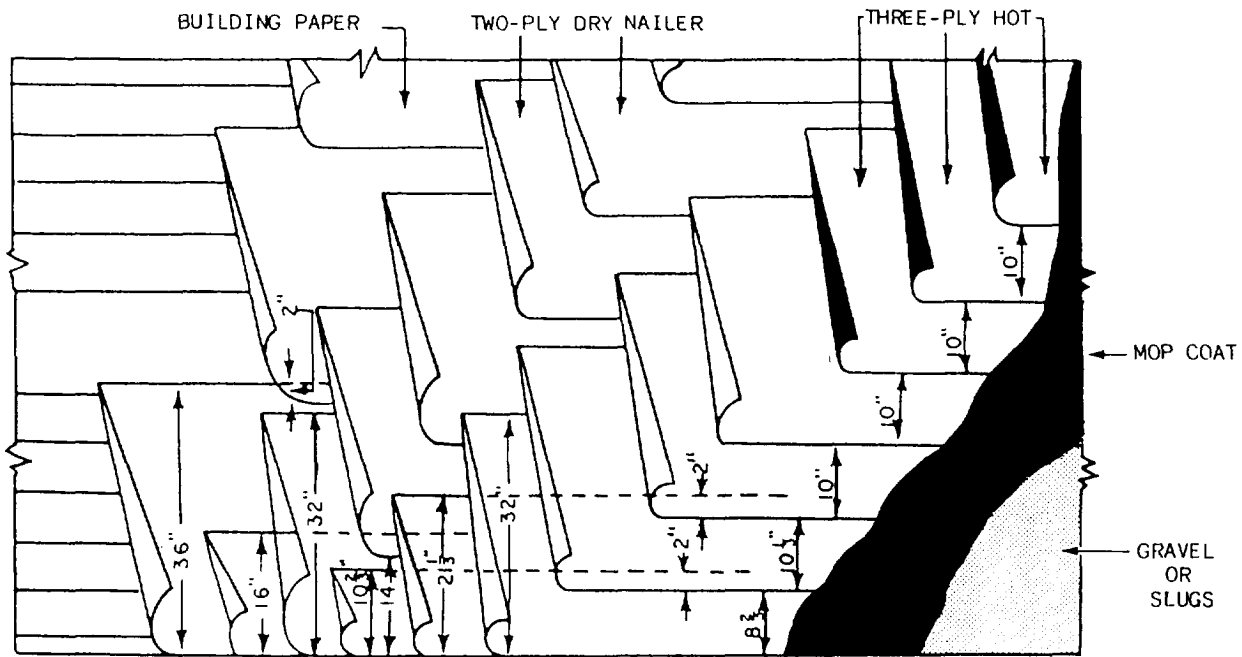

Figure 6-43-A typical building paper and felt on five-ply built-up roof.

three standard lengths: 16, 18, and 24 in. The 16-in. length is perhaps the most popular. Wood shakes are applied in much the same manner as wood shingles.

On flat roofs, the roof covering is usually built up. BUILT-UP ROOFING consists of several layers (plies) of felt, set in a hot binder of melted pitch or asphalt. Built-up roofs are always designated by the number of plies they contain. A five-ply built-up roof is shown in figure 6-43. Notice that aggregate surfacing materials, such as gravel, slag, marble, and other suitable materials, are used in built-up roofing to provide a good weathering surface and protect the bitumens from sunlight and external heat.

Exterior Trim

Before the installation of the roof sheathing is completed, the exterior finish at and just below the eaves of the roof, called CORNICE, can be constructed. The practical purpose of a cornice is to seal the joint between wall and roof against weather penetration. Purely ornamental parts of a cornice are called trim. Figure 6-44 shows a simple type of cornice, used on a roof with no rafter overhang. A roof with a rafter overhang may have the "open" cornice shown in

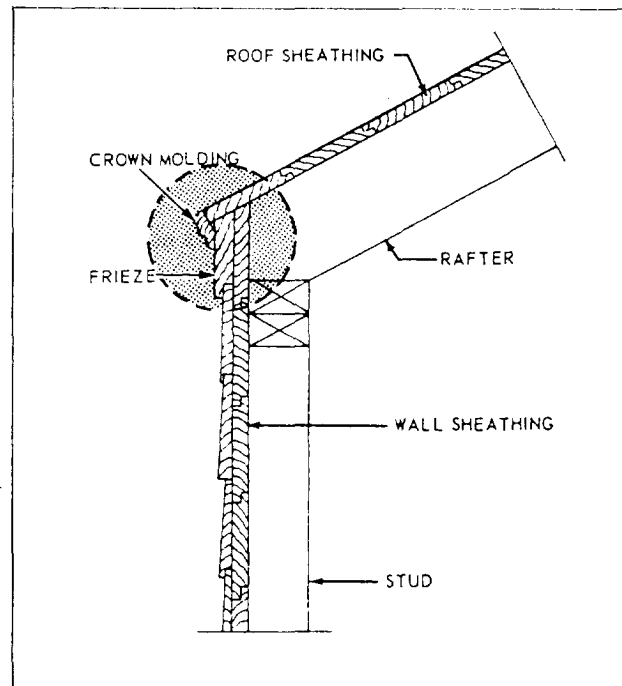

Figure 6-44. Simple cornice.

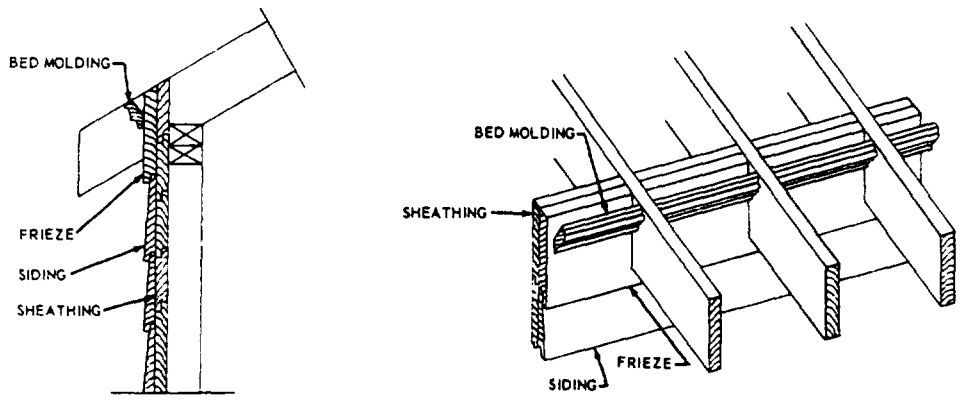

Figure 6-45.-Open cornice without a fascia board.

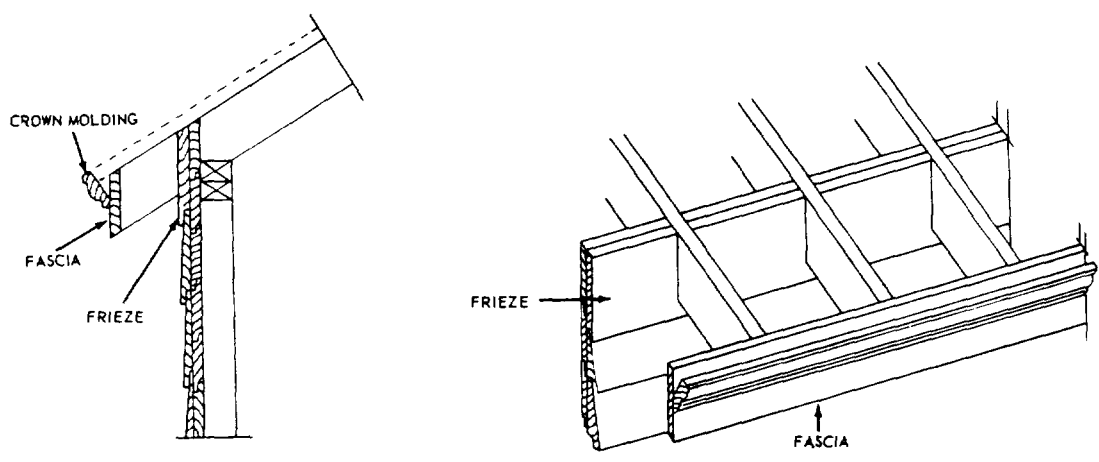

Figure 6-46.-Open cornice with a fascia board.

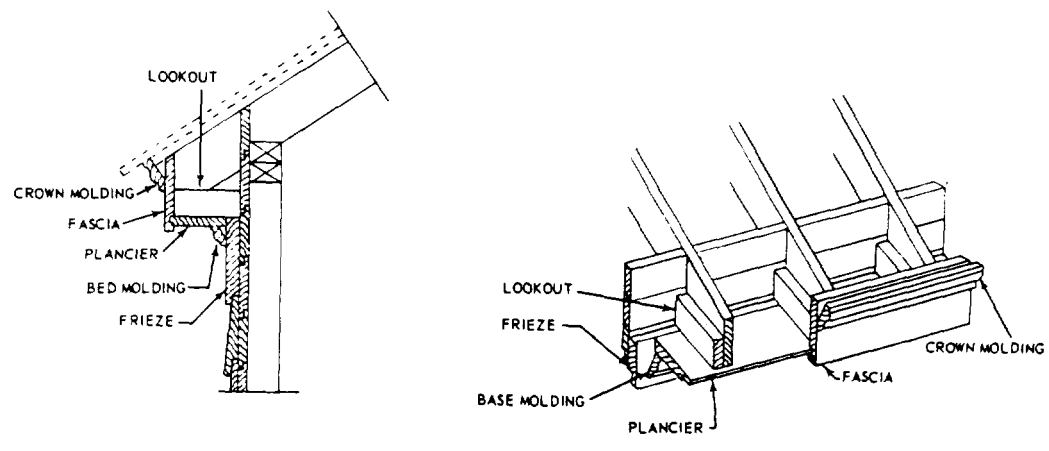

Figure 6-47.-Closed or boxed cornice.

figures 6-45 and 6-46, or the "closed" or "boxed cornice" shown in figure 6-47. A short extension of a cornice along the gable-end wall of a gable-roof structure is called cornice return (fig. 6-48). Finish along the rakes of a gable roof is called the gable cornice trim (fig. 6-49). The rafter-end edges of a roof are called EAVES. A hip roof has eaves all the way around. A gable roof has only two eaves; the gable-end or end-wall edges of a gable roof are called RAKES.

Wall Sheathing

The outside wall sheathing or covering on a frame structure consists of either wood siding or paneling, wood shingles, plywood, fiberboard, hardboard, and/or other types of materials. Masonry, veneers, metal or plastic siding, and other non-wood materials are additional choices. There are two general types of wooden board siding: drop siding and common siding. DROP SIDING (fig. 6-50) is joined edge to edge (rather than overlapping). COMMON SIDING consists of boards that overlap each other single-wise.

Boards not more than 4 ft long are called clapboard; boards in longer lengths but not more than 8 in. wide are called bevel siding. A number of drop board and common sidings can be used horizontally or vertically (fig. 6-51), and some

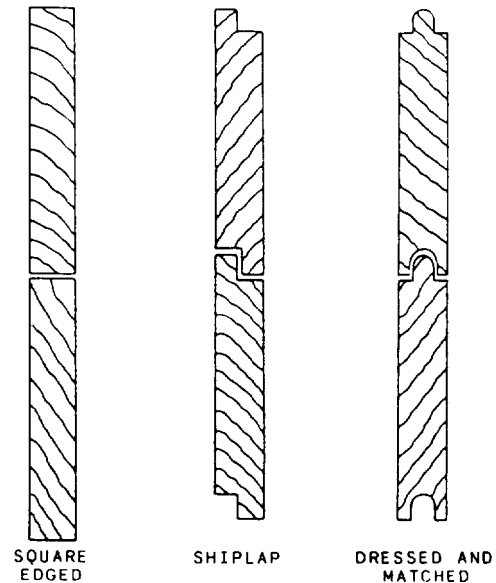

Figure 6-50. Types of drop siding.

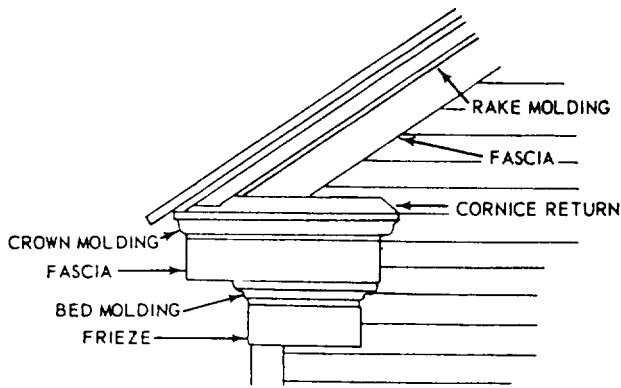

Figure 6-48. Cornice return.

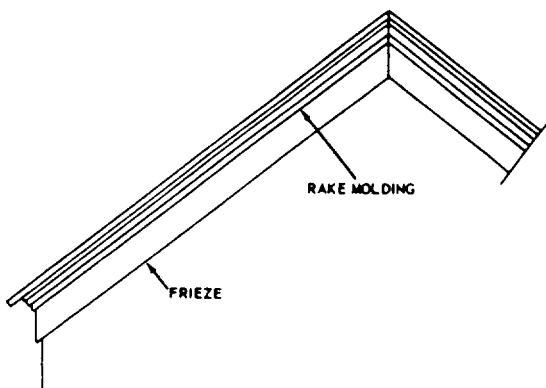

Figure 6-49. Gable cornice trim.

	TYPE	NOMINAL SIZES
	BEVEL	1/2 x 4 TO 3/4 x 10
	"ANZAC" (BEVEL)	3/4 x 12
	DOLLY VARDEN	3/4 x 6 TO 3/4 x 10
	DROP (PATTERN 106)	1 x 6 TO 1 x 8
	DROP (PATTERN 124)	1 x 6 TO 1 x 8
HORIZONTAL APPLICATION		
	PANELING (WC 130)	1 x 4 TO 1 x 12
	PANELING (WC 140)	1 x 4 TO 1 x 12
HORIZONTAL OR VERTICAL APPLICATION		

Figure 6-51. Wood siding types.

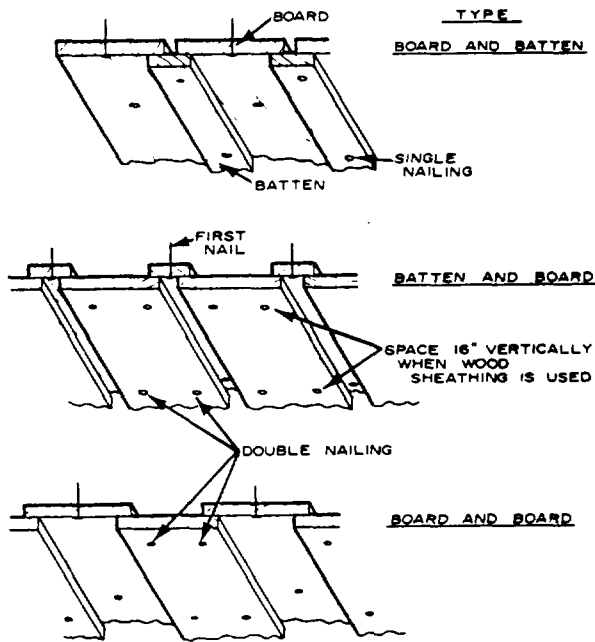

Figure 6-52.-Vertical board siding.

may be used in either manner if adequate nailing areas are provided. Figure 6-52 shows a method of vertical siding application.

Masonry veneers are used effectively with wood sidings in various exterior finishes to

enhance the aesthetic appearance of the structure. Other non-wood materials, such as stucco or a cement plaster finish, are favored for an exterior cover because they require a minimum of maintenance. Plastic films on wood sidings or plywood are also used because little or no refinishing is necessary for the life of the building.

Flashing

FLASHING is specially constructed pieces of corrosion-resistant metal or other materials used to protect buildings from water seepage. Flashing should be installed to prevent penetration of water and other moisture in the form of rain or melted snow at the junction of material changes, chimneys, and roof-wall intersection. Flashing should also be used over exposed doors, windows, and roof ridges. Figures 6-53 through 6-57 show areas or locations in which some type of flashing is required.

Flashing materials used on roofs may be asphalt-saturated felt, metal, or plastic. Felt flashing is generally used at ridges, hips, and valleys. However, metal flashing made of aluminum, galvanized steel, or copper, is considered superior to felt.

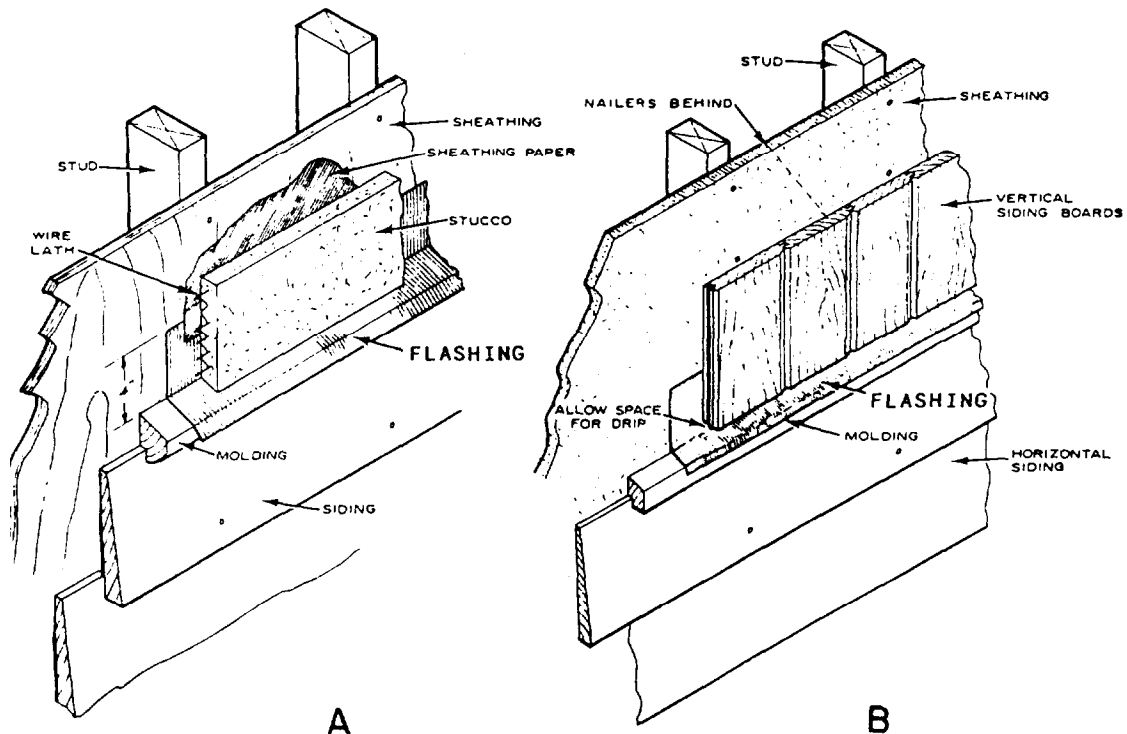

Figure 6-53.-Use of flashing at material changes: A. Stucco above, siding below; B. Vertical siding above, horizontal below,

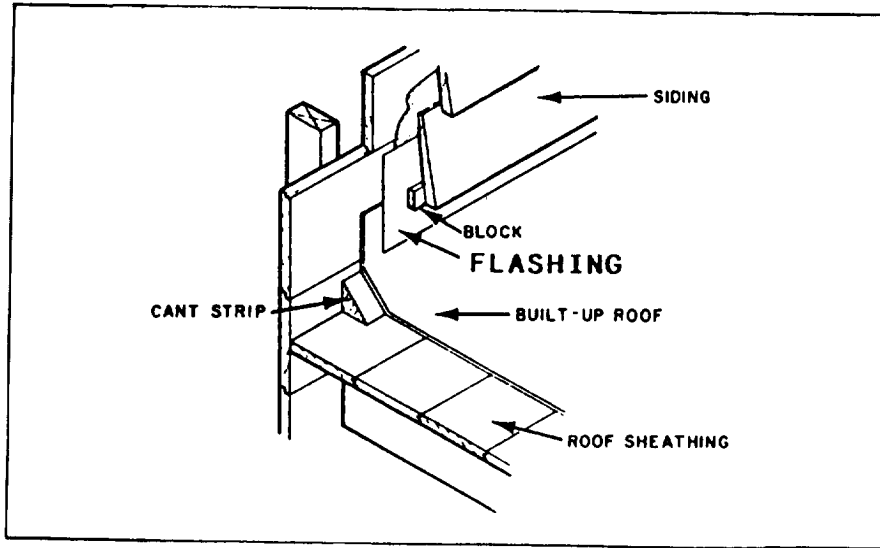

Figure 6-54.-Use of flashing at building line on built-up roof.

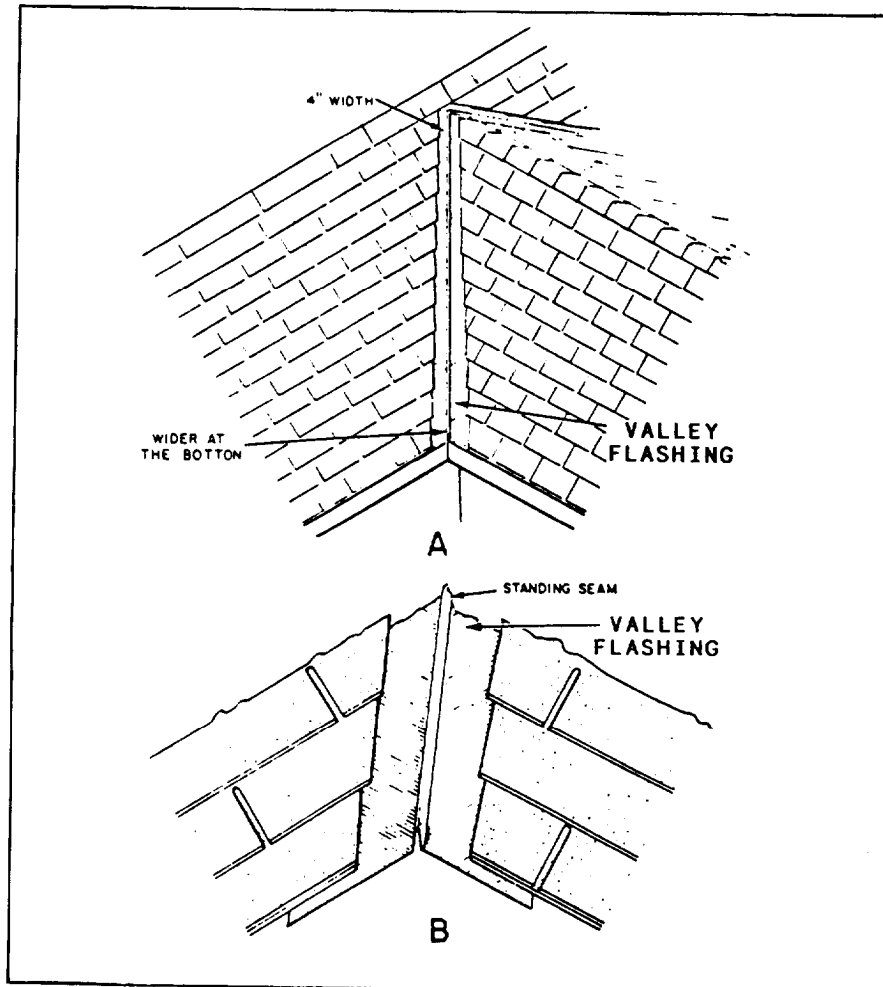

Figure 6-55.-Valley flashing: A. Valley; B. Standing seam.

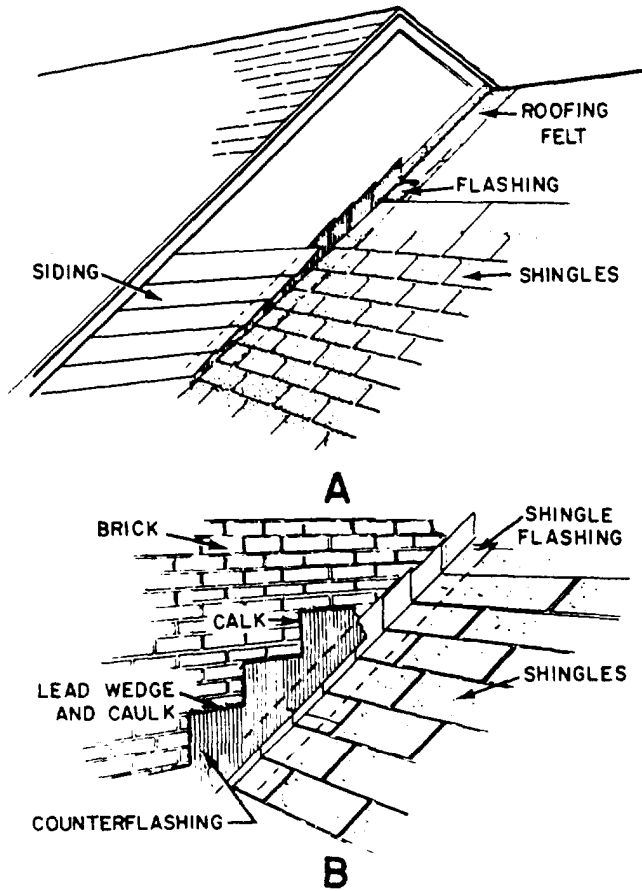

Figure 6-56-Flashing at roof and wall intersection: A. Wood siding wall; B. Brick wall.

Gutters and Downspouts

GUTTERS and DOWNSPOUTS should be installed to keep rainwater away from the foundation of the building (fig. 6-58). Some gutters are built in the cornice and connected to the downspouts (fig. 6-59). The most common types of gutters used are shown in figure 6-60. Gutters and downspouts may be made of galvanized metal, copper, or aluminum. Some have a factory-applied enamel finish. Plastic gutters and downspouts are also available.

INTERIOR FINISH

The INTERIOR FINISH consists mainly of the coverings applied to the rough inside walls, ceiling, and subfloors. Other interior finish items are ceiling and wall coverings, doorframes and window frames, stairs, floor covering, and wood trims. When required, installation of kitchen and built-in cabinets are considered part of the interior finish.

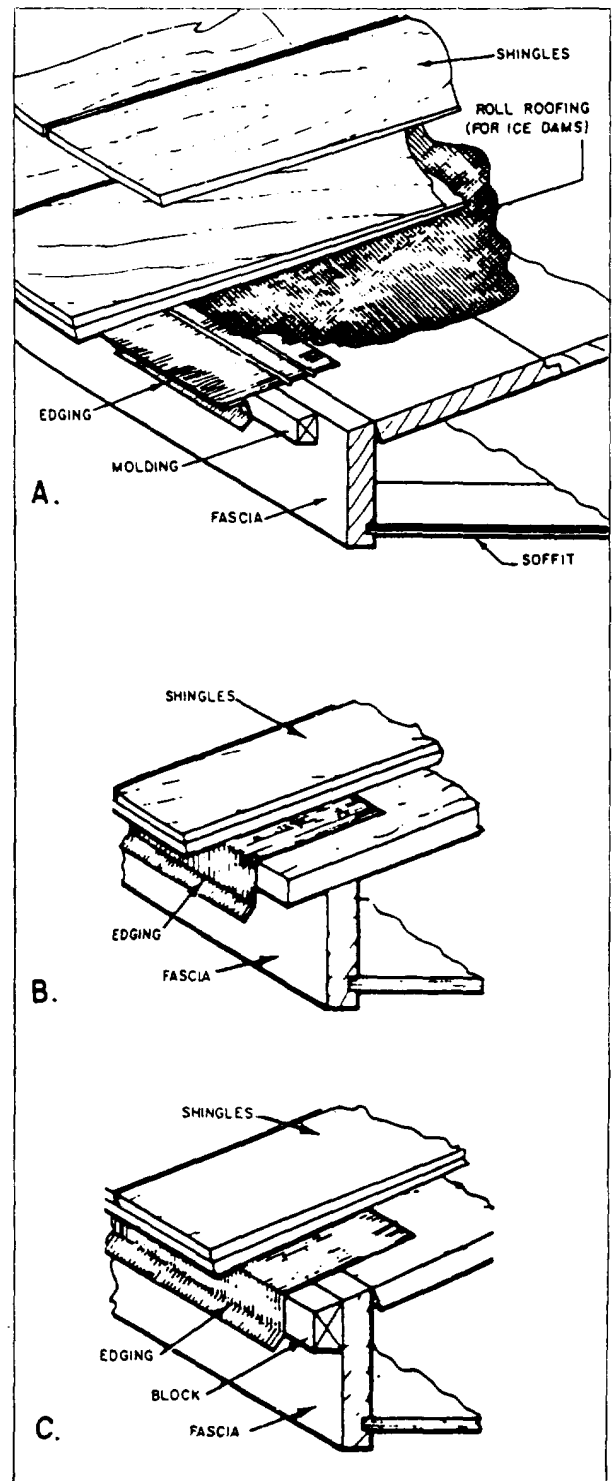

Figure 6-57.-Cornice flashing: A. Formed flashing; B. Flashing without wood blocking; C. Flashing with wood blocking.

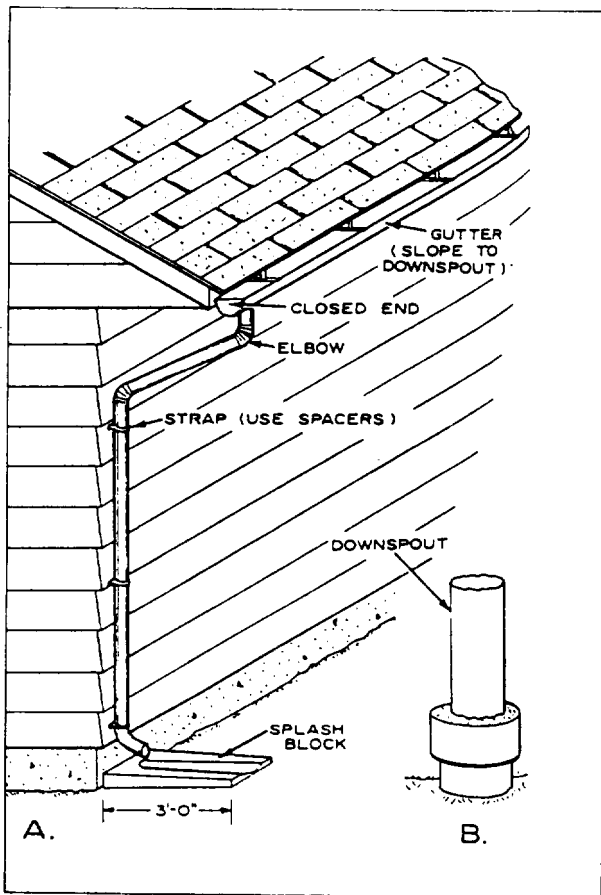

Figure 6-58-Use of gutter and downspout: A. Downspout with splash block; B. Drain to storm sewer.

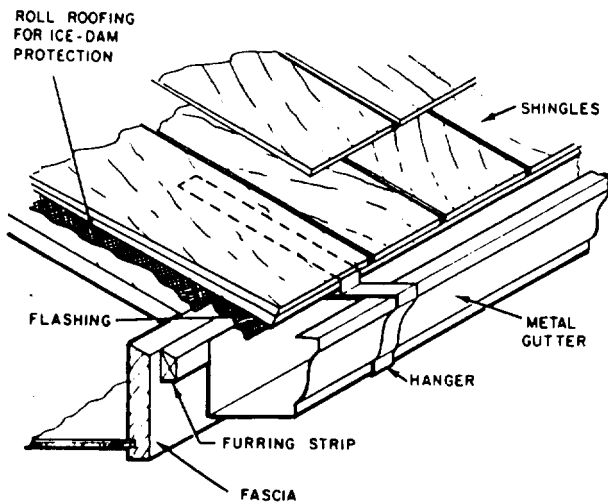

Figure 6-59.-Formed metal gutters.

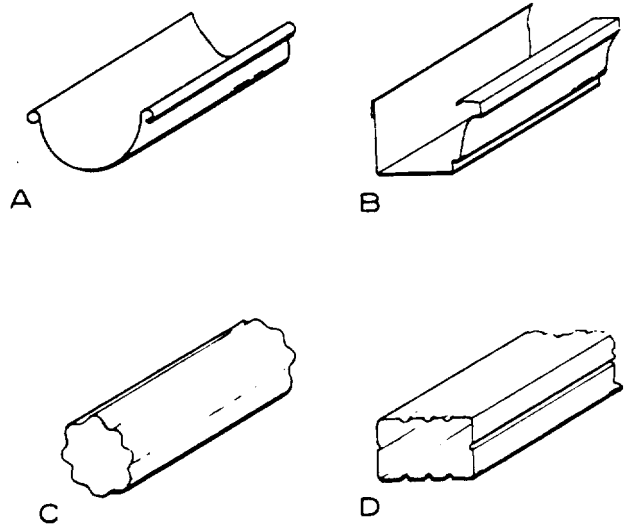

Figure 6-60.-Gutters and downspouts: A. Half-round gutter; B. Formed gutter; C. Round downspout; D. Rectangular downspout.

Ceiling and Wall Covering

Ceiling and wall covering may be broadly divided into PLASTER and DRY-WALL covering. Dry-wall covering is a general term applied to sheets or panels of wood, plywood, gypsum, fiberboard, and the like. A plaster and/or ceiling covering requires a "plaster base" and a "plaster ground" before it is installed. The plaster base, such as gypsum, fiberboard, or metal lath, provides a plane-surface base to which the plaster can be applied. Wooden strips of the same thickness as the combined thickness of the lath and plaster, called plaster ground, are installed before the lath is applied to serve as guides for the plasterers to ensure uniform plaster thickness around doorframes and window frames and behind casings.

The use of dry wall over the lath-and-plaster finish is rapidly increasing. Installation or construction time is faster with the application of dry wall. Being wet, plaster requires drying time before other interior work can be started. Gypsum is one of the most widely used types of dry-wall finishes. It is made up of a gypsum filler faced with paper or with a foil back that serves as a vapor barrier on exterior walls. It is also available with vinyl or other prefinished surfaces. It comes in 4- by 8-ft sheets and in lengths of up to 16 ft for horizontal application. Notice in

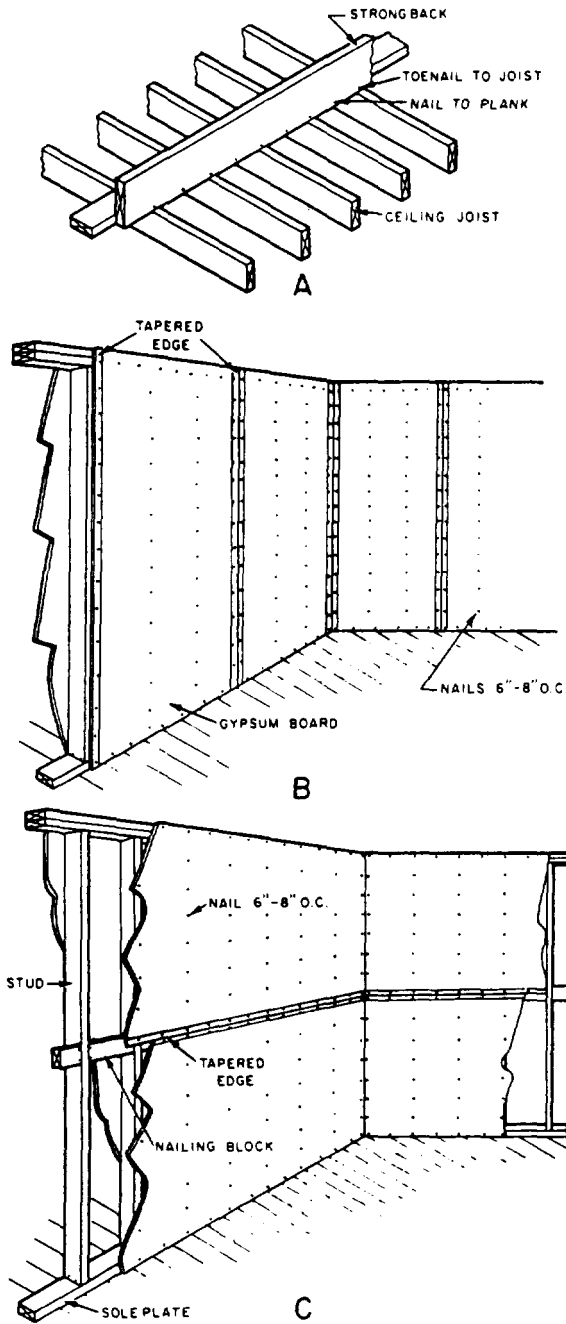

Figure 6-61—Application of gypsum board finish:
A. Strongback B. Vertical application; C. Horizontal application.

figure 6-61, view A, a “strongback” is usually used for aligning ceiling joists or studs to provide a smooth, even surface. Figures 6-62 and 6-63 show typical application of paneling using other types of dry-wall finishes.

A variety of ceiling systems can also be used to change the appearance of a room, lower a ceiling, finish off exposed joints, or provide

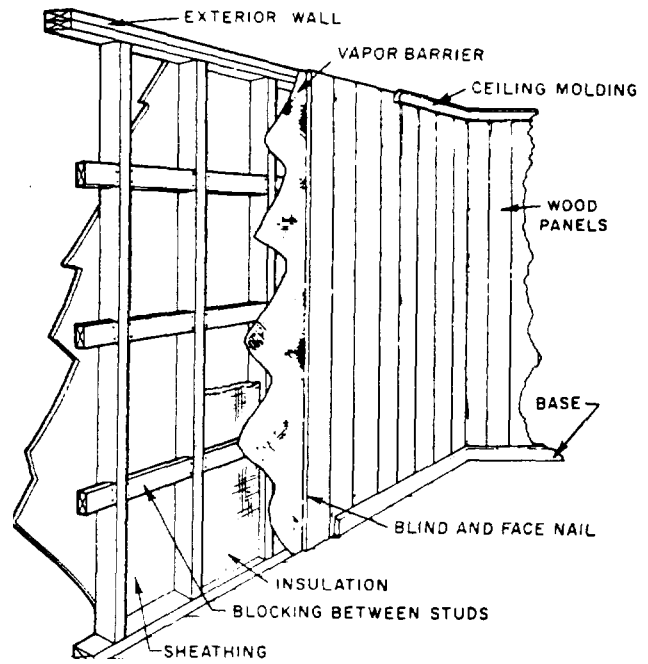

Figure 6-62.-Application of vertical paneling.

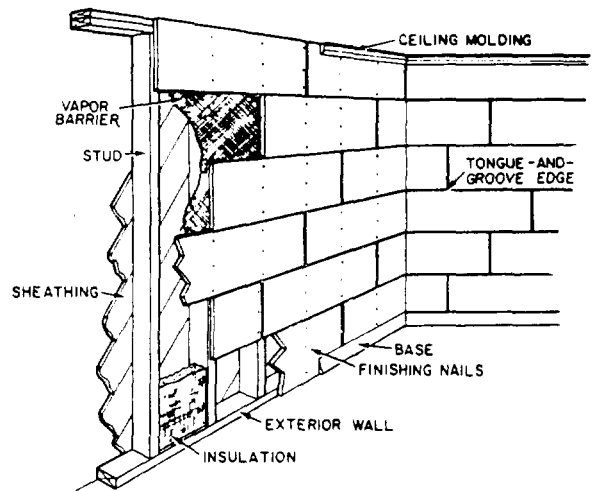

Figure 6-63.-Application of tongued-and-grooved paneling over studs.

acoustical control. Suspended acoustical ceiling systems are designed to integrate the functions of lighting, air distribution, and fire protection. Acoustical tiles, available in 12- to 30-in. widths, 12- to 60-in. lengths, and 3/16- to 3/4-in. thicknesses, are used with the other grid system components (fig. 6-64). Depending on the type of ceiling or roof construction, ceiling tiles may be installed in various ways, such as with the use of wood strips nailed across the ceiling joists or roof trusses (fig. 6-65).

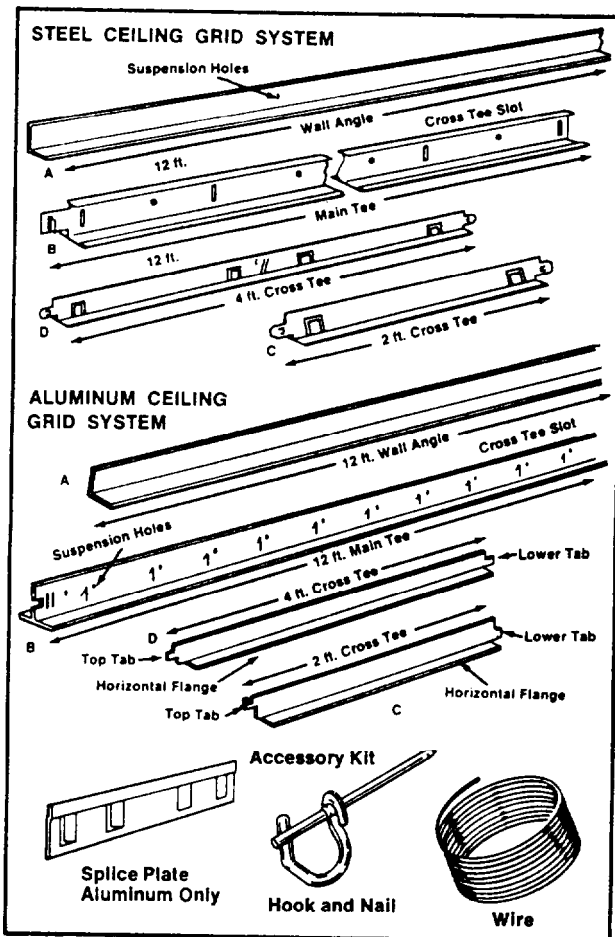

Figure 6-64. Grid system components.

Insulation and Vapor Barriers

Heat inflow or outflow has important effects upon the occupants of a building. The use of insulation improves comfort conditions and savings in fuel. The materials commonly used for insulation may be classified as blanket, batt, loose-fill, reflective, and rigid. These materials are manufactured in a variety of forms and types, and their insulating values vary with the type of construction, kinds of construction materials used, and thickness of insulation. Figure 6-66 shows different types of insulation commonly used in construction.

Vapor barriers should be used to keep moisture from seeping through walls, floors, and ceiling materials. Among the effective vapor-barrier materials are asphalt laminated papers, aluminum foil, and plastic film. Most blanket and batt insulations (fig. 6-66) have paper-backed aluminum foil on one side to serve as a vapor

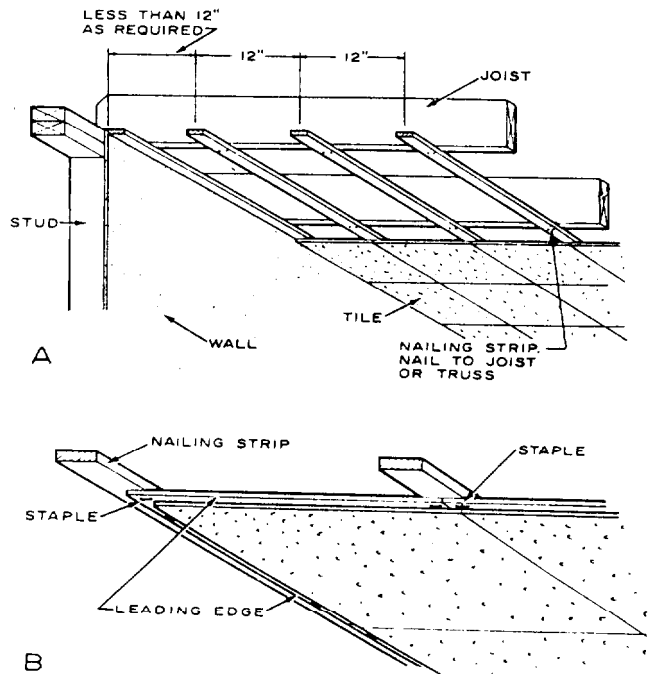

Figure 6-65. Ceiling tile assembly: A. Nailing strip location; B. Stapling.

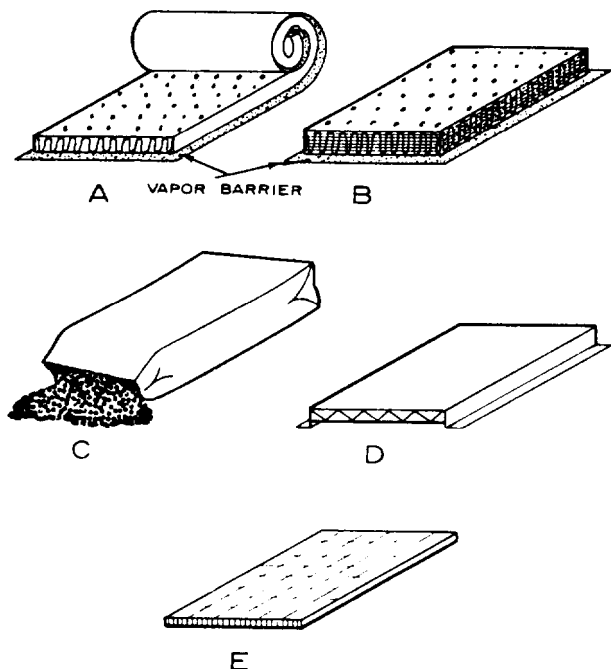

Figure 6-66. Types of insulation: A. Blanket; B. Batt; C. Fill; D. Reflective (one type); E. Rigid.

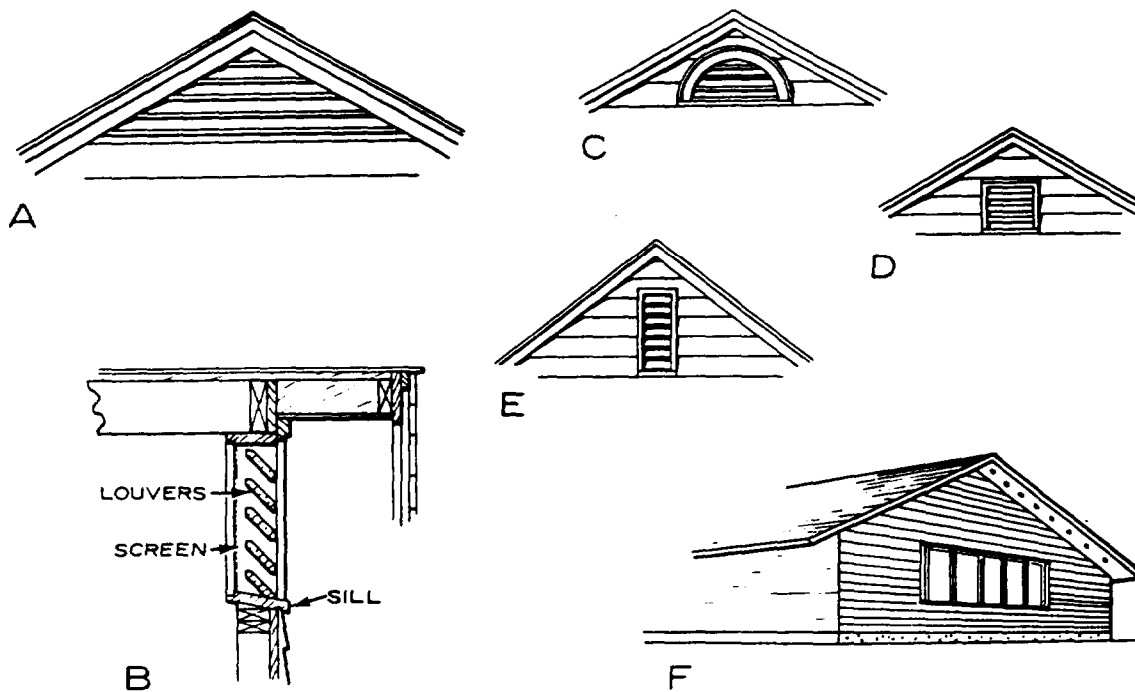

Figure 6-67.-Outlet ventilators: A. Triangular; B. Typical cross section; C. Half-circle; D. Square; E. Vertical; F. Soffit.

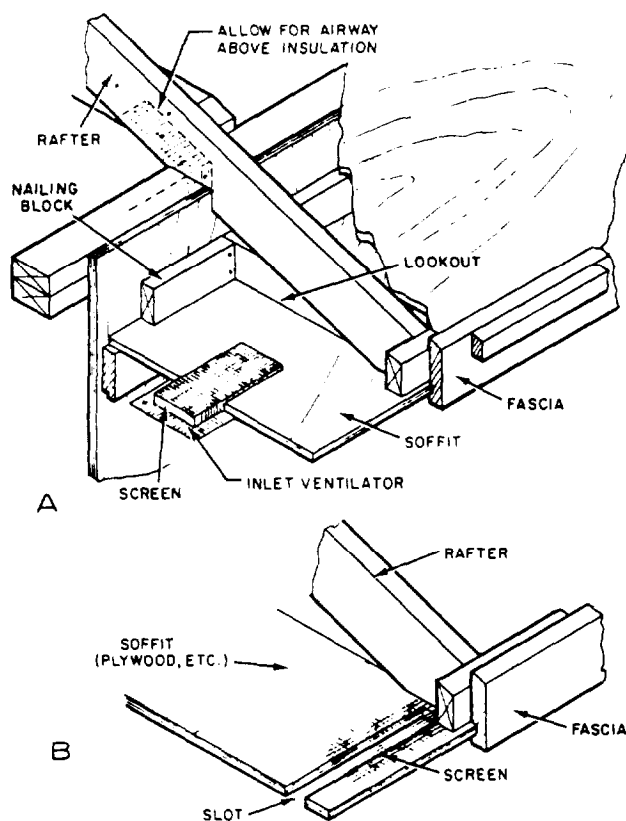

Figure 6-68.-Inlet ventilators: A. Small insert ventilator; B. Slot ventilator.

barrier. Foil-backed gypsum lath or gypsum boards are also available and serve as excellent vapor barriers. Where other types of membrane vapor barriers were not installed during construction, several coats of paint do provide some protection. Aluminum primer and then several coats of flat wall or oil paint are effective in retarding vapor transmission.

Even where vapor barriers are used, condensation of moisture vapor may occur in the attic, in roof spaces, and in crawl spaces, if any, under the building or porch. In such spaces, VENTILATION is the most practical method of removing condensed or hot air that may otherwise facilitate decay to the structure. It is common practice to install ventilators, several types of which are shown in figures 6-67 and 6-68.

Stairs

The two principal elements in a stairway are the TREADS, which people walk on, and the STRINGERS (also called springing trees, strings, horses, and carriages), which support the treads. The simplest type of stairway, shown at the left in figure 6-69, consists of these two elements alone.

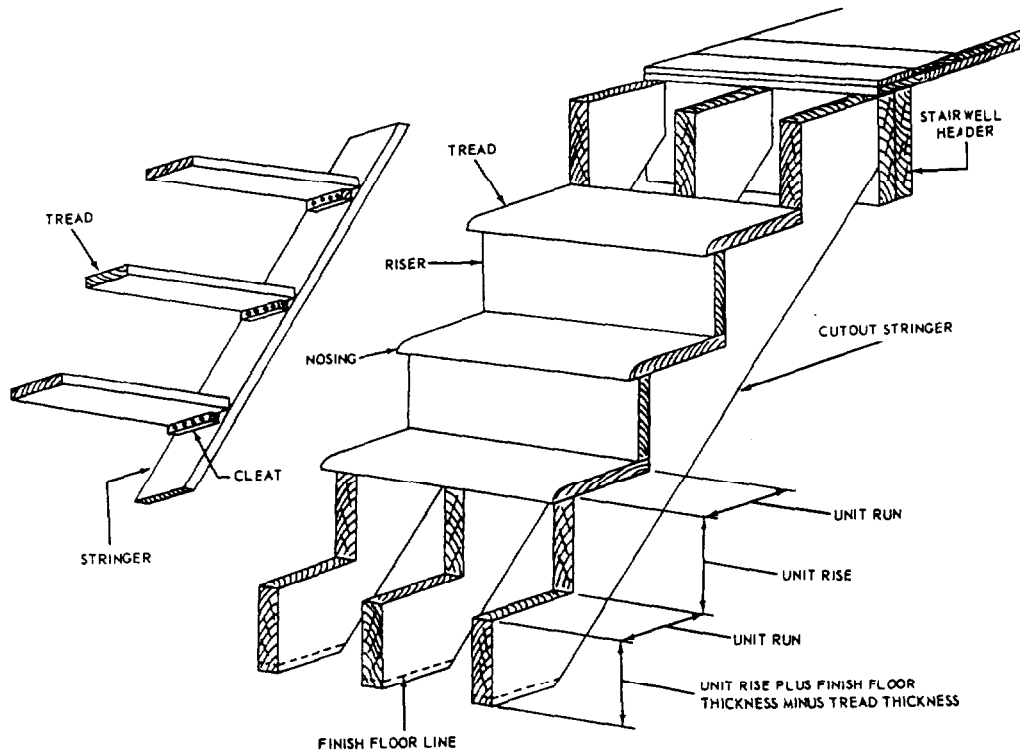

Figure 6-69.-Parts of a stairway.

Additional parts commonly used in a finished stairway are shown at the right in figure 6-69. The stairway shown here has three stringers, each of which is sawed out of a single timber. For this reason, a stringer of this type is commonly called

a **CUTOUT** or **SAWED** stringer. On some stairways, the treads and risers are nailed to triangular stair blocks attached to straight-edged stringers.

A stairway that continues in the same straight line from one floor to the next is called a **STRAIGHT-FLIGHT** stairway. When space does **NOT** permit the construction of one of these, a **CHANGE** stairway (one that changes direction one or more times between floors) is installed. A change stairway in which there are platforms between sections is called a **PLATFORM** stairway.

Stairs in a structure are divided into **PRINCIPAL STAIRS** and **SERVICE STAIRS**. Principal stairs are those extending between floors above the basement and below the attic floor. Porch, basement, and attic stairs are service stairs. The lower ends of the stringers on porch, basement, and other stairs anchored on concrete are fastened with a kickplate (fig. 6-70).

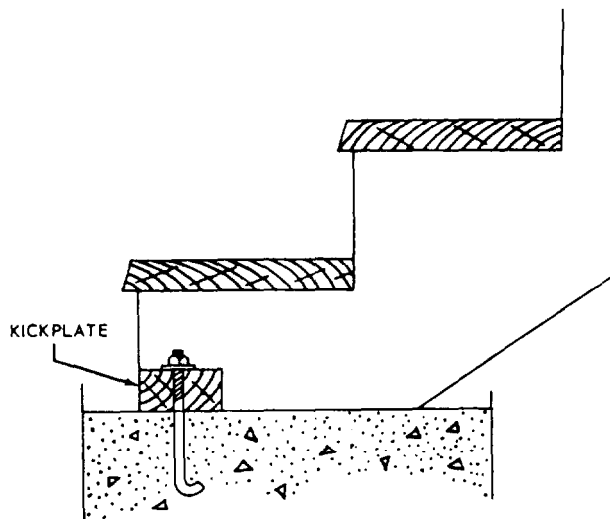

Figure 6-70.-Kickplate for anchoring stairs to concrete.

Finish Flooring

Finish flooring is broadly divided into wood finish flooring and resilient finish flooring. Most wood finish flooring comes in strips that are

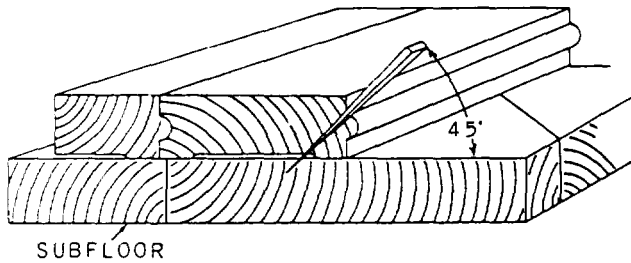

Figure 6-71.-Toenailing wood finish flooring.

side-matched; that is, tongue-and-grooved for edge-joining; some is end-matched as well. Wood flooring strips are usually recessed on the lower face and toenailed through the subflooring into joists, as shown in figure 6-71.

In Navy structures, wood finish flooring has been largely supplanted by various types of resilient flooring, most of which is applied in the form of 6 by 6, 9 by 9, or 12 by 12 floor tiles. Materials commonly used are asphalt, linoleum, cork, rubber, and vinyl. With each type of tile, the manufacturer recommends an appropriate type of adhesive for attaching the tile to the subflooring.

On other areas subject to a high degree of dampness, ceramic or glazed interior tile is most commonly used. Ceramic tiles are used to cover

all or part of the bathrooms, shower rooms, and some kitchen floors.

Doors

Standard doors and combination doors (storm and screen) are millwork items that are usually fully assembled at the factory and ready for use in the building. All wood components are treated with a water-repellent preservative to provide protection against the elements. Doors are manufactured in different styles, as shown in figure 6-72.

Exterior doors, outside combination doors, and storm doors may be obtained in a number of designs to fit the style of almost any building. Doors in the traditional pattern are usually of the panel type (fig. 6-72, view A). A PANEL DOOR consists of stiles (solid vertical members), rails (solid cross members), and filler panels in a number of designs. Exterior FLUSH DOORS use a solid-core, rather than hollow-core type to minimize warping. (Warping is caused by a difference in moisture content on the exposed and unexposed faces of the door.) Weatherstripping should be installed on exterior doors to reduce both air infiltration and frosting of the glass on the storm door during cold weather. Flush doors consist of thin plywood faces over a framework of wood with a wood block or particleboard core.

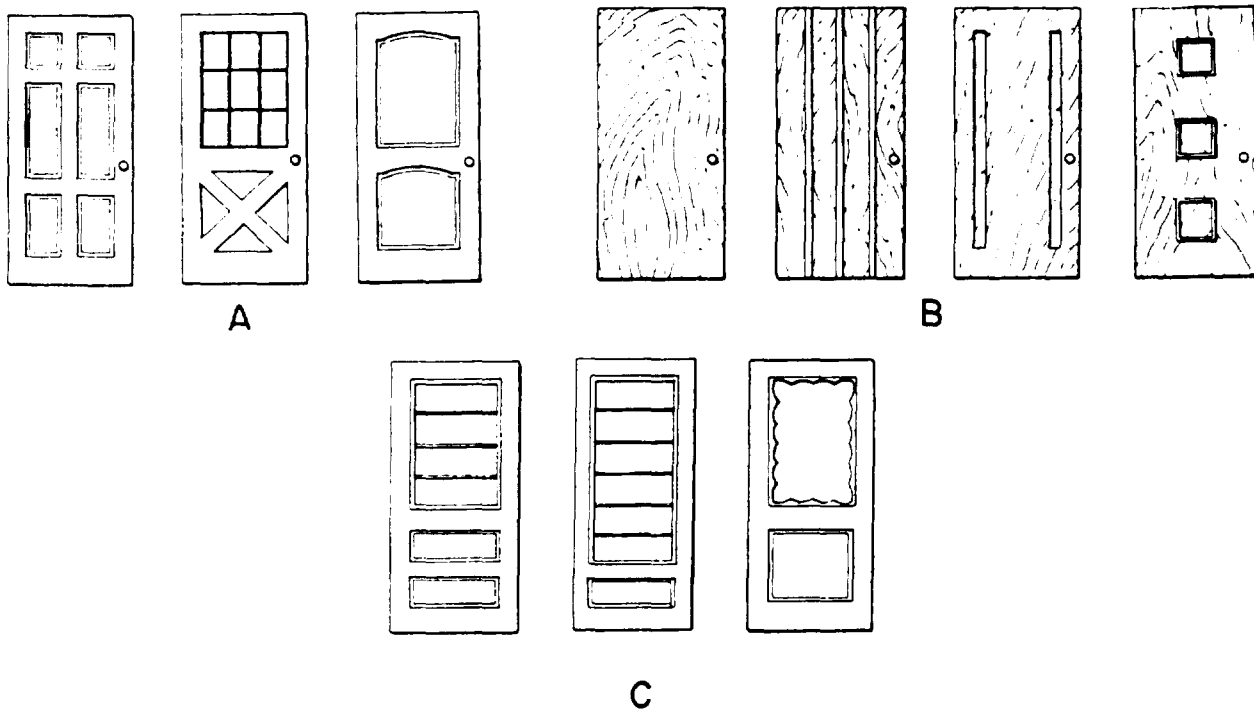

Figure 6-72.-Exterior doors: A. Traditional panel; B. Flush; C. Combination.

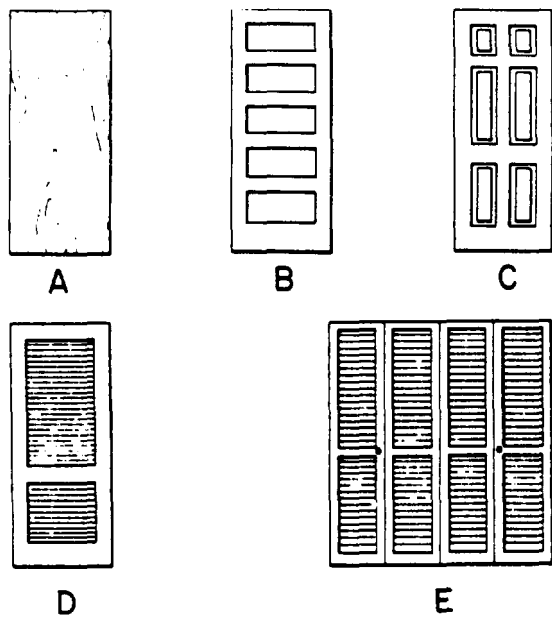

Figure 6-73-Interior doors: A. Flush; B. Panel (five-cross); C. Panel (colonial); D. Louvered; E. Folding (louvered).

Exterior doors are usually 1 3/4 in. thick and not less than 6 ft 8 in. high. The main entrance door is 3 ft wide, and the side or rear door is normally 2 ft 8 in. wide. The exterior trim used can vary from a simple CASING (the trim used around the edges of door openings and also as a finishing trim on the room side of windows and exterior door-frames) to a molded or plain pilaster.

Similarly, interior doors also come in many styles (fig. 6-73). The two principal types are flush and panel doors. Interior panel doors (colonial and five-cross type) are manufactured to be similar to the exterior doors, Novelty doors, such as the folding door unit, are commonly used for closets because they provide ventilation. The interior flush door is usually made up with a hollow core of light framework covered with thin plywood or hardboard. Most standard interior doors are 1 3/8 in. thick.

Hinged doors should open or swing in the direction of natural entry, against a blank wall, and should not be obstructed by other swinging doors. Doors should NEVER be hinged to swing into a hallway.

Figure 6-74 shows the principal parts of a finish doorframe. On an outside door, the frame

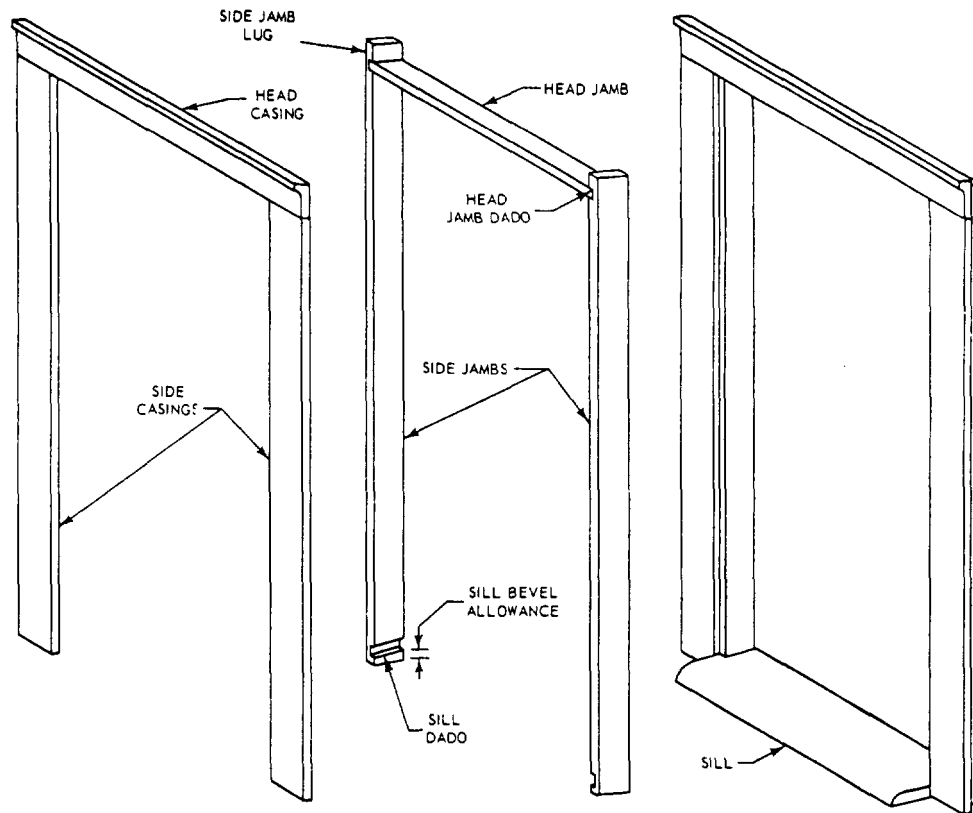

Figure 6-74.-Principal parts of a finish doorframe.

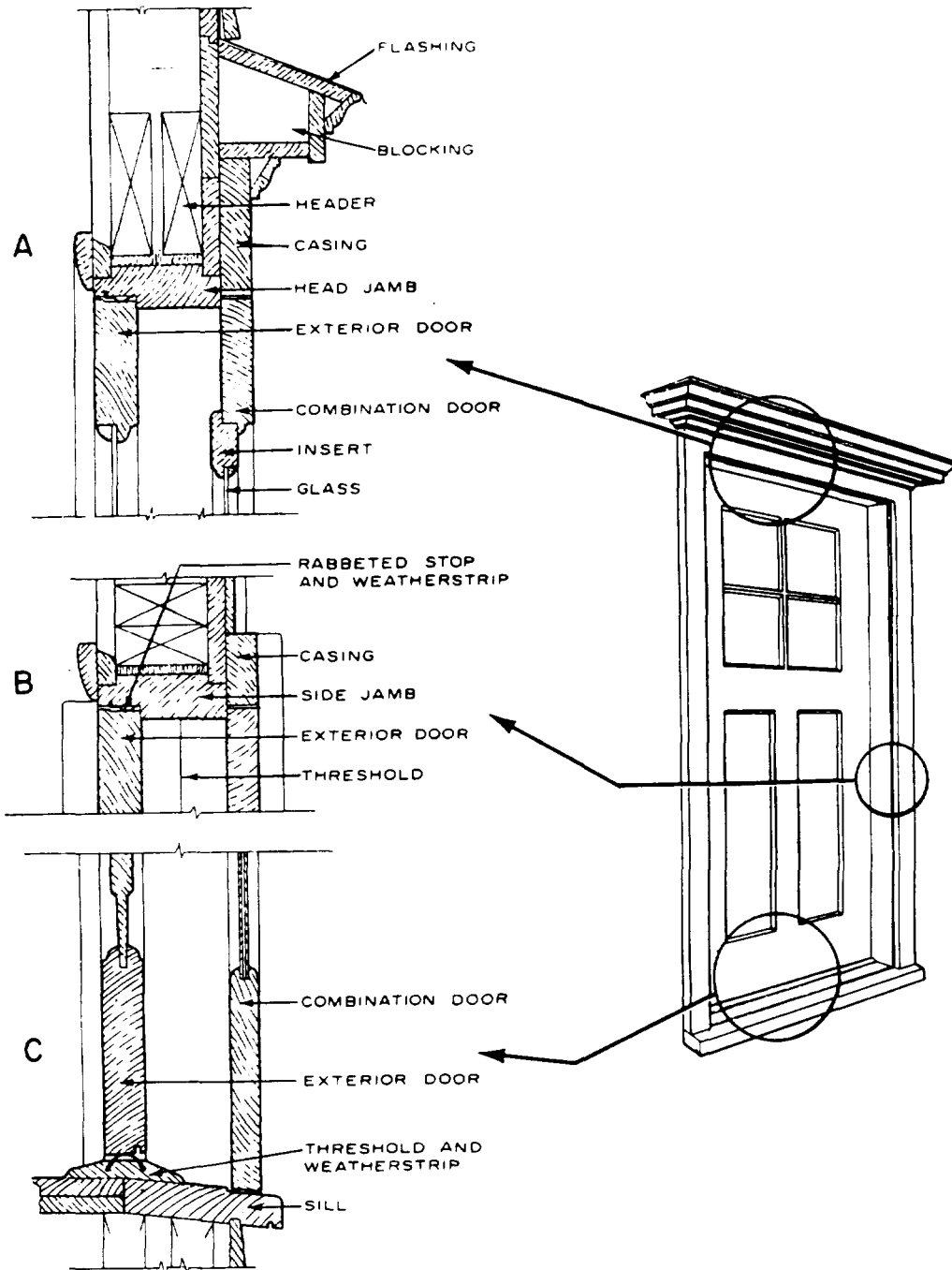

Figure 6-75.-Exterior door and frame. Exterior door and combination door (screen and storm) cross sections: A. Head jamb; B. Side jamb; C. Sill.

includes the side and head casings. On an inside door, the frame consists only of the side and head jambs; the casings are considered part of the inside-wall covering.

Figure 6-75 shows section drawings of exterior doorframe details.

Windows

The part of a window that forms a frame for the glass is called sash, and window sash is considered part of the interior, not the exterior, finish. However, a window with a sash that is

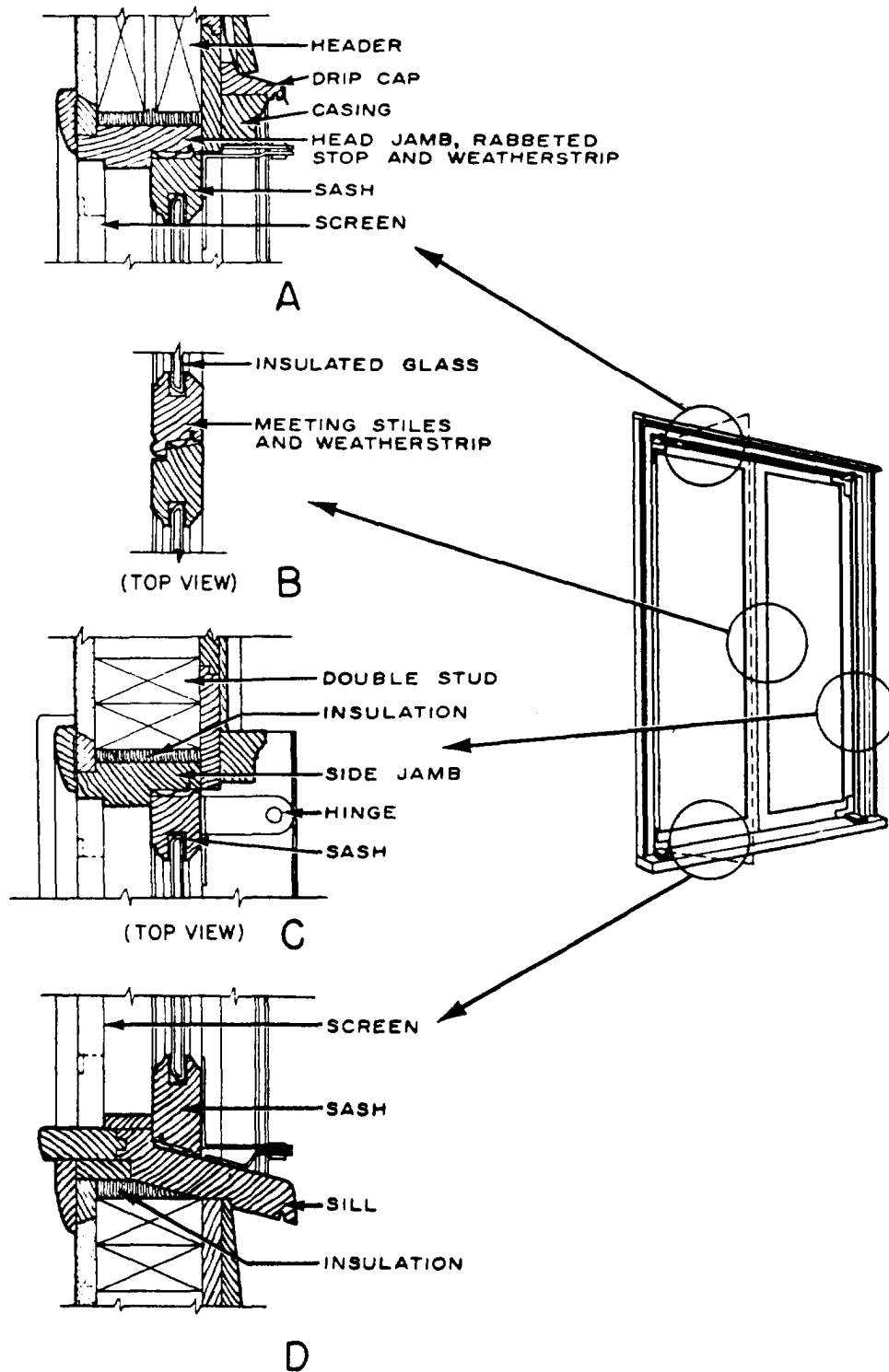

Figure 6-76.-Outswinging casement sash. Cross sections: A. Head jamb; B. Meeting stiles; C. Side jambs; D. Sill.

hinged at the side is called a casement window (fig. 6-76)—single casement if there is only one sash, double casement if there are two. A window that is hinged at the top or bottom is called a transom window. One with a number of

horizontally hinged sashes that open and close together like the slats in a venetian blind is a jalousie window. A window having two sashes that slide vertically past each other is a double-hung window.

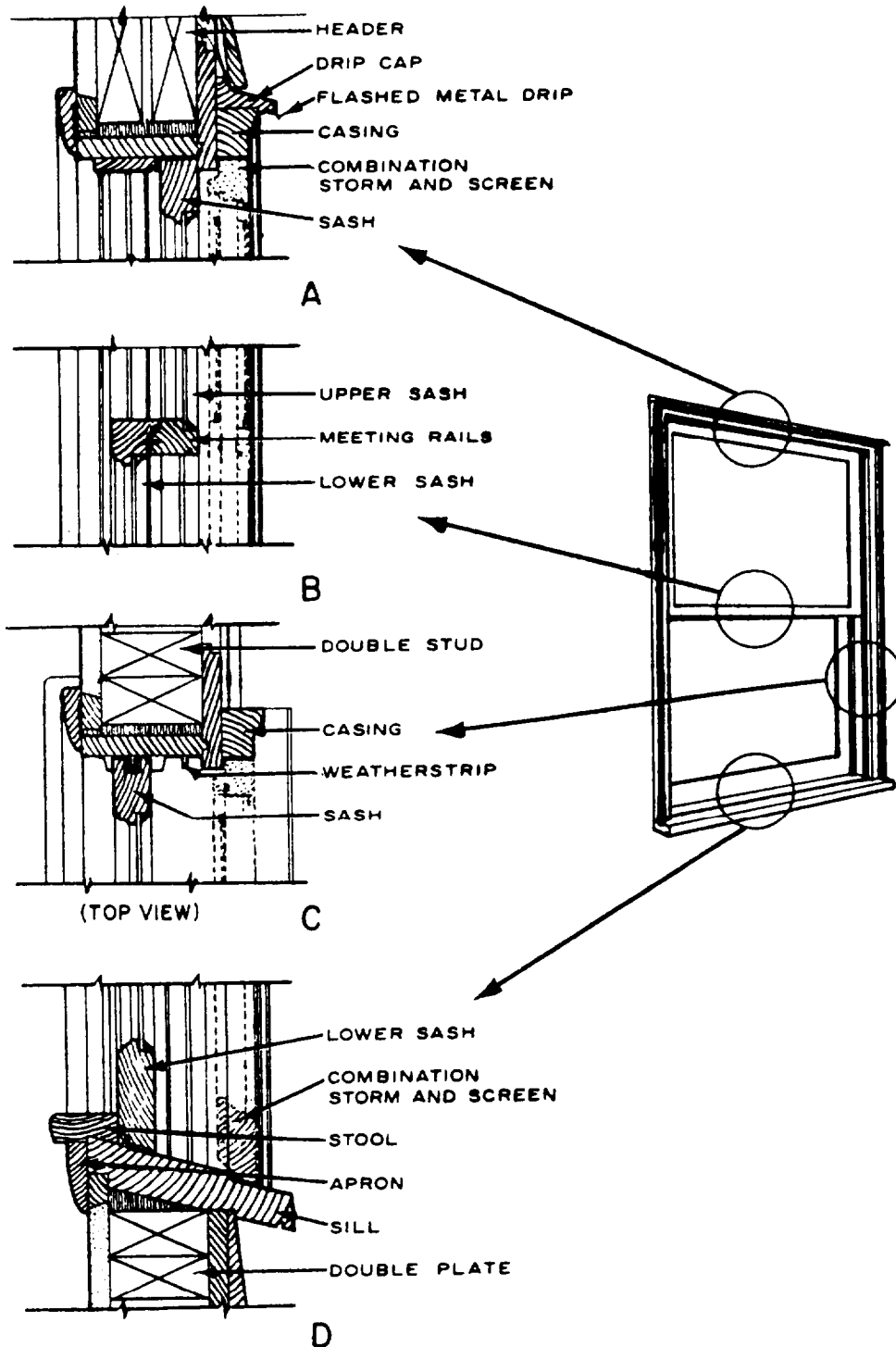

Figure 6-77.-Double-hung windows. Cross sections: A. Head jamb; B. Meeting rails; C. Side jambs; D. Sill.

Basically, the finish frames for all of these are much alike, consisting principally, like a finish doorframe, of side jambs, head jamb, sill, and outside casing (the inside casing being considered part of the inside-wall covering). However, a double-hung window

frame contains some items that are NOT used on frames for other types of windows. Section drawings showing head- and side-jamb details for a double-hung window are shown in figure 6-77. Sill details are shown in figure 6-78.

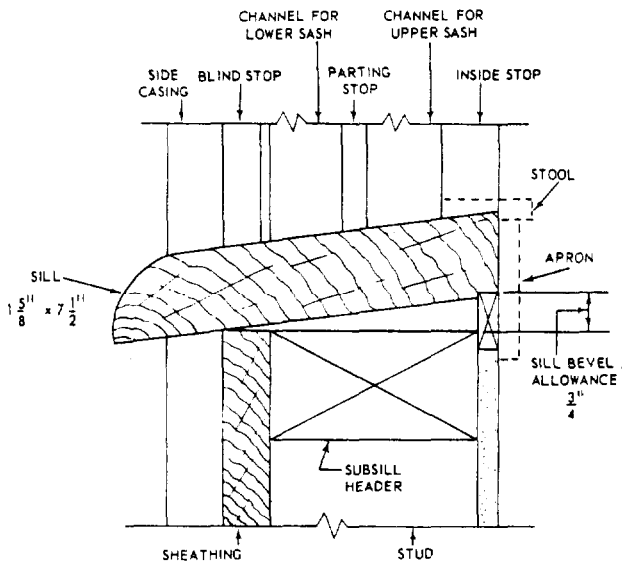

Figure 6-78.-Sill detail for a double-hung window.

A window schedule on the construction drawings gives the dimensions, type, such as casement, double-hung, and so forth, and the number of lights (panes of glass) for each window in the structure. A window might be listed on the schedule as, for example, No. 3, DH, 2 ft 4 in. by 3 ft 10 in., 12 LTS. This means that window No. 3 (it will have this number on any drawing in which it is shown) is a double-hung window with a finished opening, measuring 2 ft 4 in. by 3 ft 10 in. and having 12 lights of glass. In any view in which the window appears, the arrangement of the lights will be shown. On one of the lights, a figure such as 8/10 will appear. This means that each light of glass has nominal dimensions of 8 by 10 in.

Figure 6-79 shows a double-hung window sash and the names of its parts.

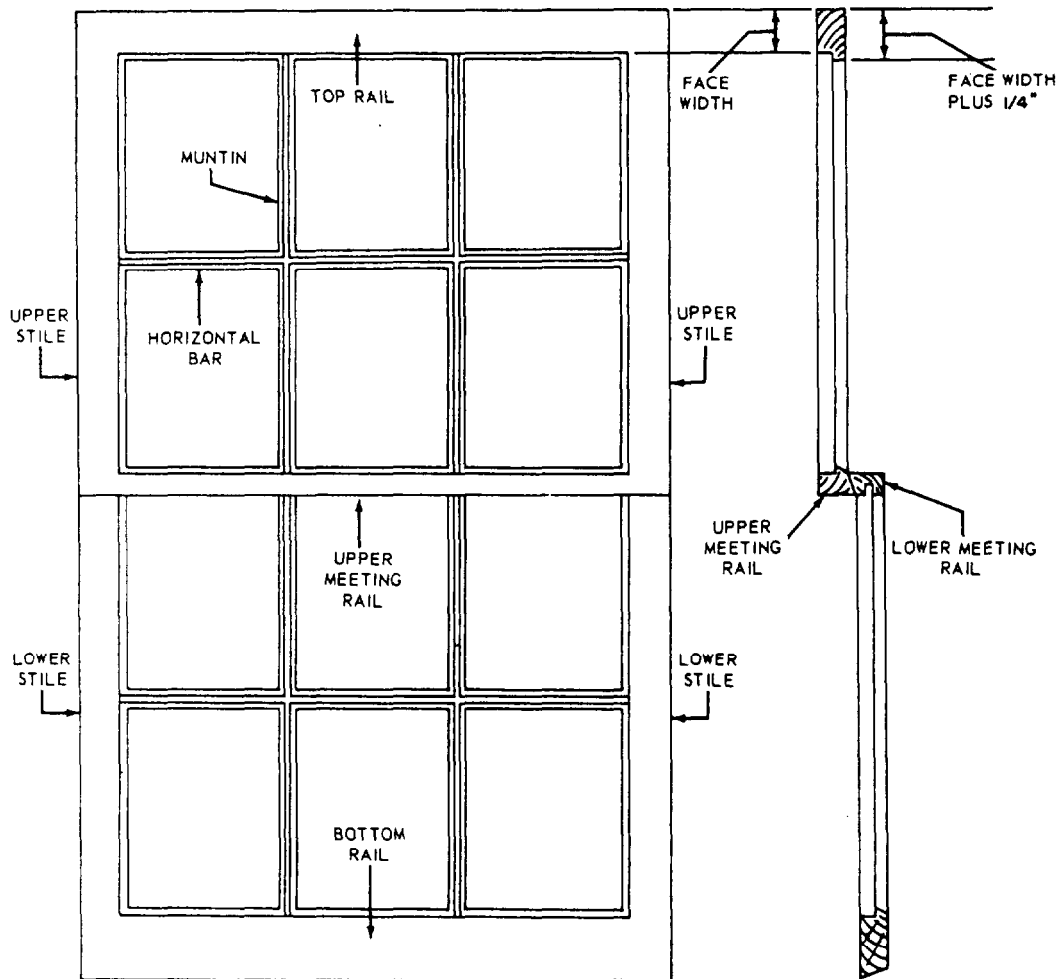

Figure 6-79.-Parts of a double-hung window sash.

Wood Trims

The most prominent items in the interior trim are the inside door and the window casings, which may be plain-faced or ornamentally molded in various ways. Another item is the baseboard, which covers the joint between an inside wall and finish floor (fig. 6-80). Baseboards or base molding are available in several widths and forms. Figures 6-81 and 6-82 show areas where some types of molding are desirable.

HARDWARE

HARDWARE is a general term covering a wide variety of accessories that are usually made of metal or plastic and ordinarily used in building construction. Hardware includes both finishing and rough hardware.

FINISHING HARDWARE consists of items that are made in attractive shapes and finishes and are usually visible as an integral part of the finished structure. Included are locks, hinges, door pulls, cabinet hardware, window fastenings,

door closers and checks, door holders, and automatic exit devices. In addition, there are the lock-operating trim, such as knobs and handles, escutcheon plates, strike plates, and knob rosettes. There are also push plates, push bars, kickplates, doorstops, and flush bolts.

ROUGH HARDWARE consists of items that are NOT usually finished for an attractive appearance. These items include casement and special window hardware, sliding and folding door supports, and fastenings for screens, storm windows, shades, venetian blinds, and awnings.

Other items may be considered hardware. If you are not sure whether an item is hardware or what its function is, refer to a commercial text, such as the *Architectural Graphic Standards*.

FASTENERS

The devices used in fastening or connecting members together to form structures depend on the kinds of material the members are made of.

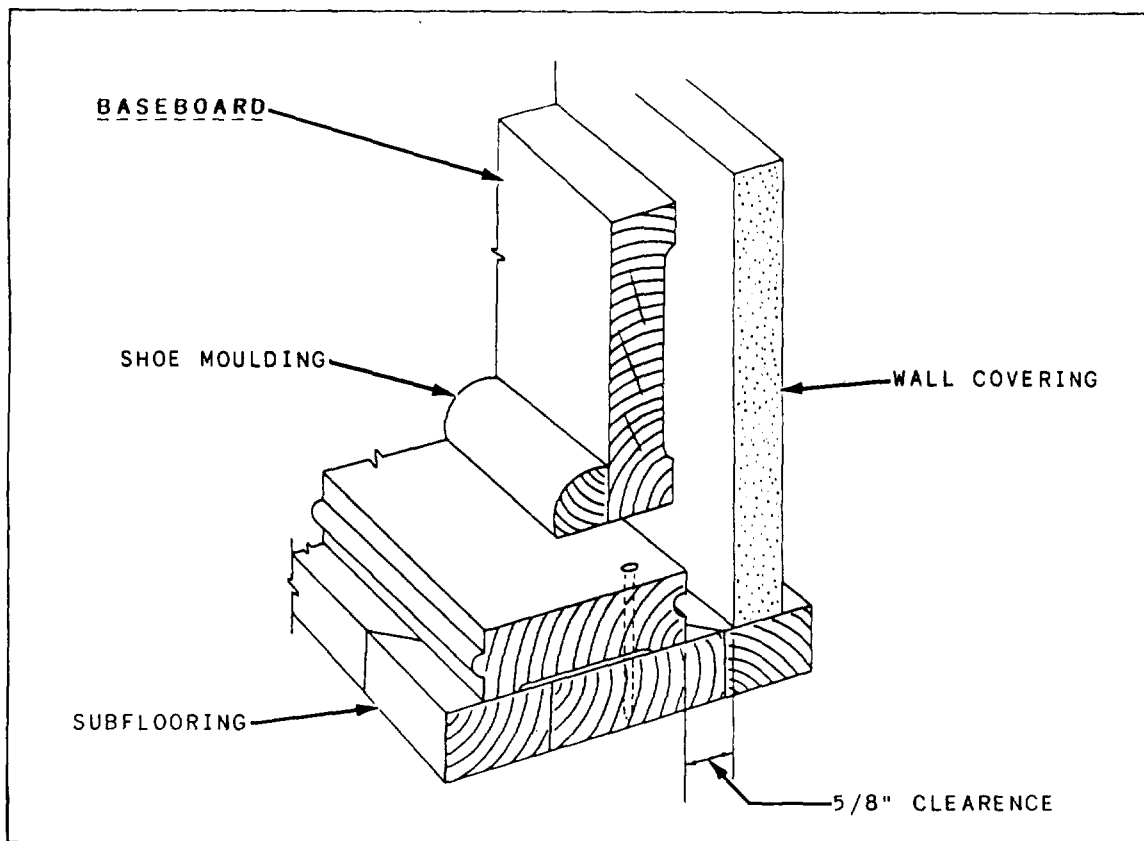

Figure 6-80.-Baseboard.

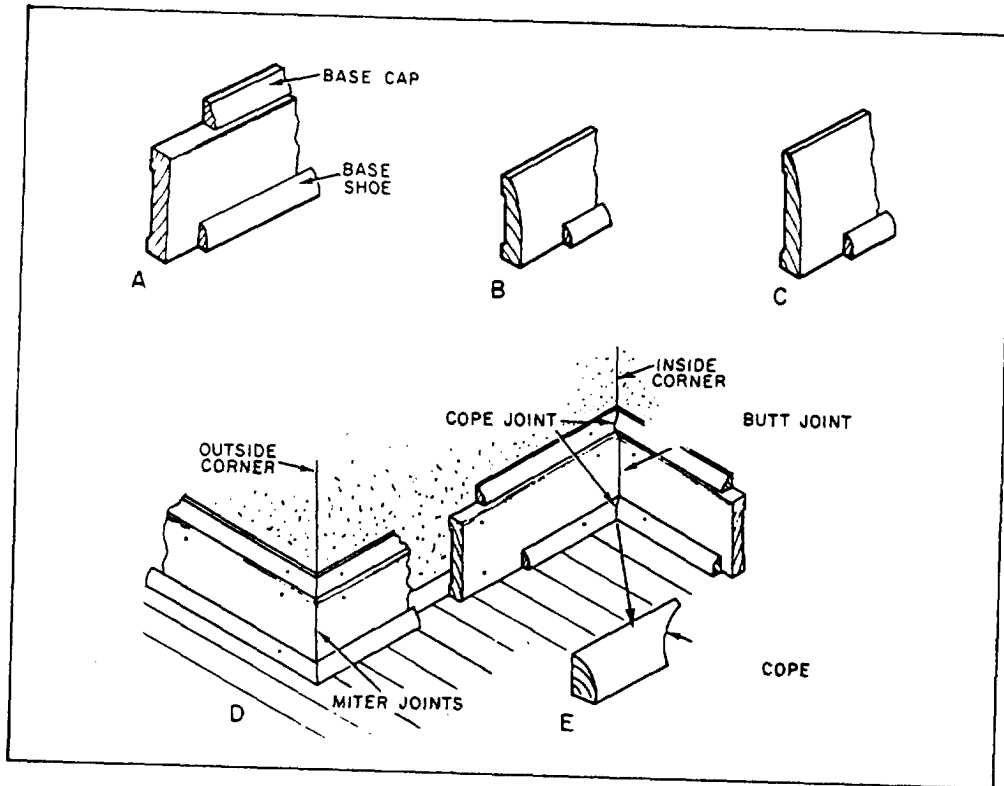

Figure 6-81.-Base moldings: A. Square-edge base; B. Narrow ranch base; C. Wide ranch base; D. Installation; E. Cope.

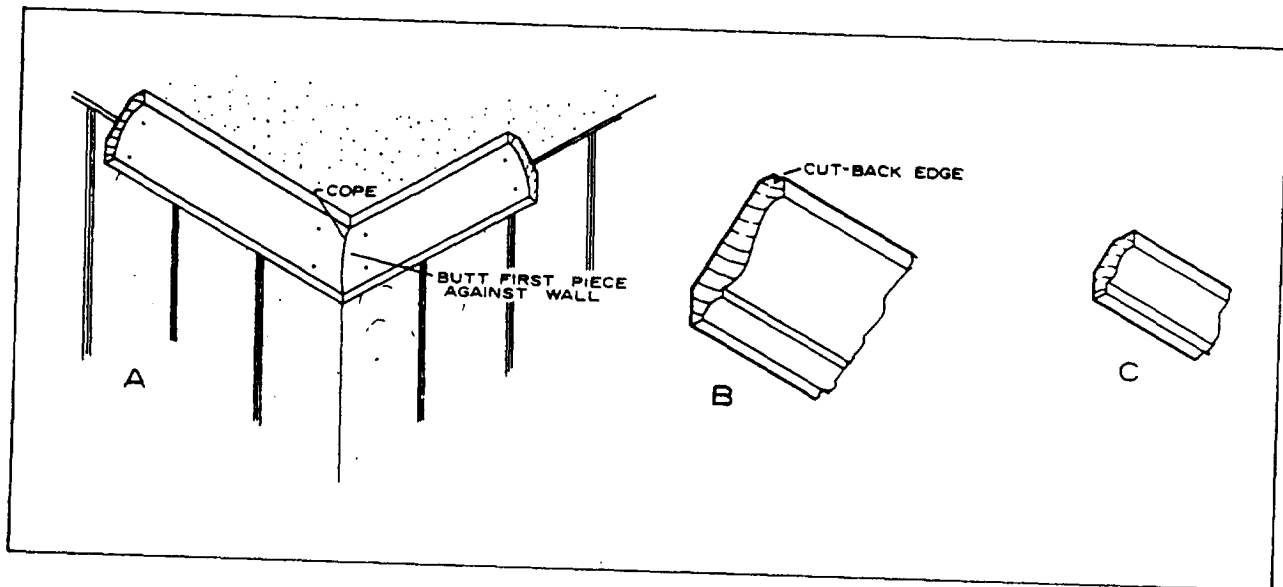
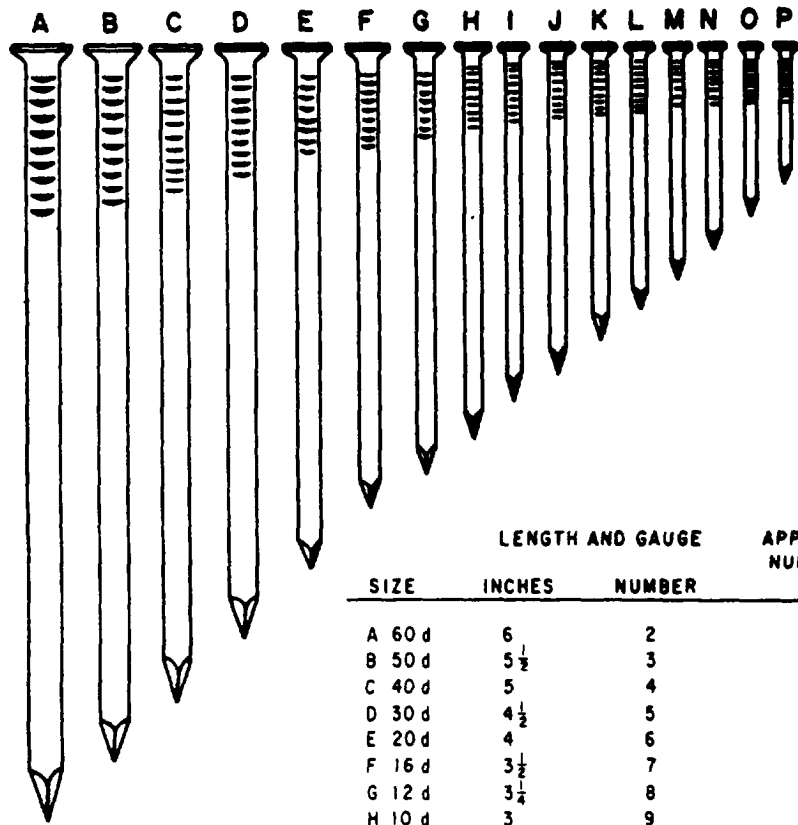
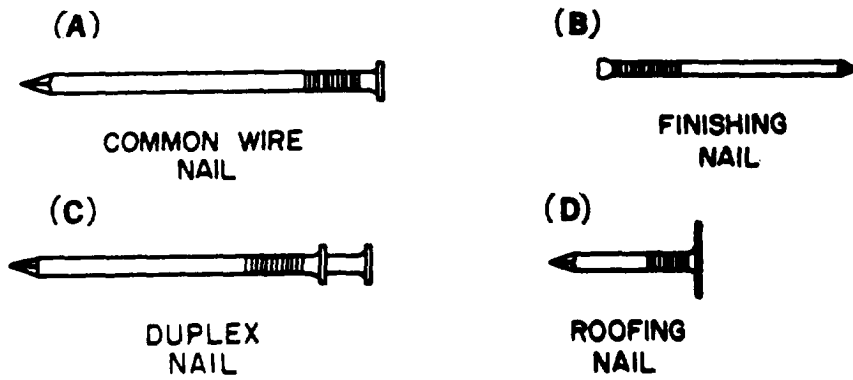

Figure 6-82.-Ceiling moldings: A. Installation (inside corner); B. Crown molding; C. Small crown molding.



COMMON WIRE NAILS

SIZE	LENGTH AND GAUGE		APPROXIMATE NUMBER TO POUND
	INCHES	NUMBER	
A 60 d	6 $\frac{1}{2}$	2	11
B 50 d	5 $\frac{1}{2}$	3	14
C 40 d	5	4	18
D 30 d	4 $\frac{1}{2}$	5	24
E 20 d	4	6	31
F 16 d	3 $\frac{1}{2}$	7	49
G 12 d	3 $\frac{1}{4}$	8	63
H 10 d	3	9	69
I 9 d	2 $\frac{3}{4}$	10 $\frac{1}{4}$	96
J 8 d	2 $\frac{1}{2}$	10 $\frac{1}{4}$	106
K 7 d	2 $\frac{1}{4}$	11 $\frac{1}{2}$	161
L 6 d	2	11 $\frac{1}{2}$	181
M 5 d	1 $\frac{3}{4}$	12 $\frac{1}{2}$	271
N 4 d	1 $\frac{1}{2}$	12 $\frac{1}{2}$	316
O 3 d	1 $\frac{1}{4}$	14	568
P 2 d	1	15	876

Figure 6-83.-Types and sizes of common wire nails and other nails.

The most common fastening devices are nails, screws, and bolts.

Nails

There are many types of nails—all of which are classified according to their use and form. The standard nail is made of steel wire. The wire nail is round-shafted, straight, pointed, and may vary in size, weight, size and shape of head, type of point, and finish. The holding power of nails is less than that of screws or bolts.

The COMMON WIRE nail and BOX nail (fig. 6-83, view A) are the same, except that the wire sizes are one or two numbers smaller for a given length of the box nail than they are for the common nail. The FINISHING nail (fig. 6-83, view B) is made from finer wire and has a smaller head than the common nail. Its head may be driven below the surface of the wood, which leaves only a small hole that is easily puttied. The DUPLEX nail (fig. 6-83, view C) seems to have two heads. Actually one serves as a shoulder to give maximum holding power while the other projects above the surface of the wood to make

withdrawal simple. The ROOFING NAIL (fig. 6-83, view D) is round-shafted and galvanized. It has a relatively short body and comparatively large head. Like the common wire, finishing, or duplex nail, it has a diamond point.

Besides the general-purpose nails shown in figure 6-83, there are special-purpose nails. Examples include wire brads, plasterboard nails, concrete nails, and masonry nails. The wire brad has a needlepoint; the plasterboard nail has a large-diameter flathead. The concrete nail is specially hardened for driving in concrete. So is the masonry nail, although its body is usually grooved or spiraled.

Lengths of wire nails NOT more than 6 in. long are designated by the penny system, where the letter *d* is the symbol for a penny. Thus, a 6d nail means a sixpenny nail. The thickness of a wire nail is expressed by the number, which relates to standard wire gauge. Nail sizes (penny and length in inches), gauges, and approximate number of nails per pound are given in figure 6-83. Nails longer than 6 in. (called SPIKES) are not designated by the penny. The general size and type of nail preferable for specific applications are shown in table 6-4.

Table 6-4.-Size, Type, and Use of Nails

SIZE	LGTH (IN.) ¹	DIAM (IN.)	REMARKS	WHERE USED
2d	1	.072	SMALL HEAD	FINISH WORK, SHOP WORK.
2d	1	.072	LARGE FLATHEAD	SMALL TIMBER, WOOD SHINGLES, LATHES.
3d	1½	.08	SMALL HEAD	FINISH WORK, SHOP WORK.
3d	1½	.08	LARGE FLATHEAD	SMALL TIMBER, WOOD SHINGLES, LATHES.
4d	1½	.098	SMALL HEAD	FINISH WORK, SHOP WORK.
4d	1½	.098	LARGE FLATHEAD	SMALL TIMBER, LATHES, SHOP WORK.
5d	1¾	.098	SMALL HEAD	FINISH WORK, SHOP WORK.
5d	1¾	.098	LARGE FLATHEAD	SMALL TIMBER, LATHES, SHOP WORK.
6d	2	.113	SMALL HEAD	FINISH WORK, CASING, STOPS, ETC., SHOP WORK.
6d	2	.113	LARGE FLATHEAD	SMALL TIMBER, SIDING, SHEATHING, ETC., SHOP WORK.
7d	2½	.113	SMALL HEAD	CASING, BASE, CEILING, STOPS, ETC.
7d	2½	.113	LARGE FLATHEAD	SHEATHING, SIDING, SUBFLOORING, LIGHT FRAMING.
8d	2½	.131	SMALL HEAD	CASING, BASE, CEILING, WAINSCOT, ETC., SHOP WORK.
8d	2½	.131	LARGE FLATHEAD	SHEATHING, SIDING, SUBFLOORING, LIGHT FRAMING, SHOP WORK.
8d	1¾	.131	EXTRA-LARGE FLATHEAD	ROLL ROOFING, COMPOSITION SHINGLES.
9d	2¾	.131	SMALL HEAD	CASING, BASE, CEILING, ETC.
9d	2¾	.131	LARGE FLATHEAD	SHEATHING, SIDING, SUBFLOORING, FRAMING, SHOP WORK.
10d	3	.148	SMALL HEAD	CASING, BASE, CEILING, ETC., SHOP WORK.
10d	3	.148	LARGE FLATHEAD	SHEATHING, SIDING, SUBFLOORING, FRAMING, SHOP WORK.
12d	3½	.148	LARGE FLATHEAD	SHEATHING, SUBFLOORING, FRAMING.
16d	3½	.162	LARGE FLATHEAD	FRAMING, BRIDGES, ETC.
20d	4	.192	LARGE FLATHEAD	FRAMING, BRIDGES, ETC.
30d	4½	.207	LARGE FLATHEAD	HEAVY FRAMING, BRIDGES, ETC.
40d	5	.225	LARGE FLATHEAD	HEAVY FRAMING, BRIDGES, ETC.
50d	5½	.244	LARGE FLATHEAD	EXTRA-HEAVY FRAMING, BRIDGES, ETC.
60d	6	.262	LARGE FLATHEAD	EXTRA-HEAVY FRAMING, BRIDGES, ETC.

¹THIS CHART APPLIES TO WIRE NAILS, ALTHOUGH IT MAY BE USED TO DETERMINE THE LENGTH OF CUT NAILS.

Screws

A wood screw is a fastener that is threaded into the wood. Wood screws are designated by the type of head (fig. 6-84) and the material from which they are made; for example, flathead brass or round-head steel. The size of a wood screw is designated by its length in inches and a number relating to its body diameter—meaning the diameter of the unthreaded part. This number runs from 0 (about 1/15-in. diameter) to 24 (about 3/8-in. diameter).

Lag screws, called LAG BOLTS (fig. 6-84), are often required where ordinary wood screws are too short or too light, or where spikes do not hold securely. They are available in lengths of 1 to 16 in. and in body diameters of 1/4 to 1 in. Their heads are either square or hexagonal.

Sheet metal, sheet aluminum, and other thin metal parts are assembled with SHEET METAL screws and THREAD-CUTTING screws (fig. 6-84). Sheet metal screws are self-tapping; they

can fasten metals up to about 28 gauge. Thread-cutting screws are used to fasten metals that are 1/4 in. thick or less.

Bolts and Driftpins

A steel bolt is a fastener having a head at one end and threads at the other, as shown in figure 6-85. Instead of threading into wood like a screw, it goes through a bored hole and is held by a nut. Stove bolts range in length from 3/8 to 4 in. and in body diameter from 1/8 to 3/8 in. Not especially strong, they are used only for fastening light pieces. CARRIAGE and MACHINE bolts are strong enough to fasten load-bearing members, such as trusses. In length, they range from 3/4 to 20 in.; in diameter, from 3/16 to 3/4 in. The carriage bolt has a square section below its head which embeds in the wood as the nut is set up, keeping the bolt from turning. An expansion bolt is used in conjunction with an expansion shield to provide anchorage in a position in which a threaded fastener alone is useless,

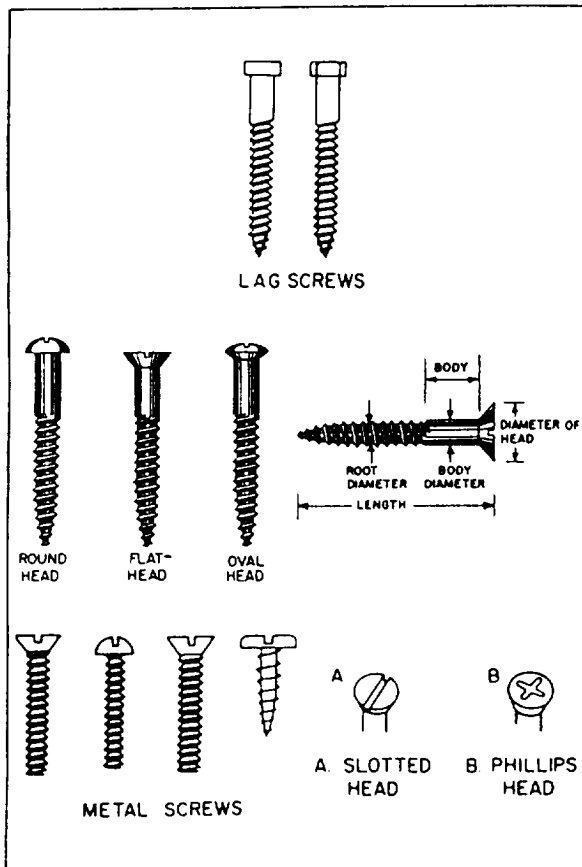

Figure 6-84. Types of screws.

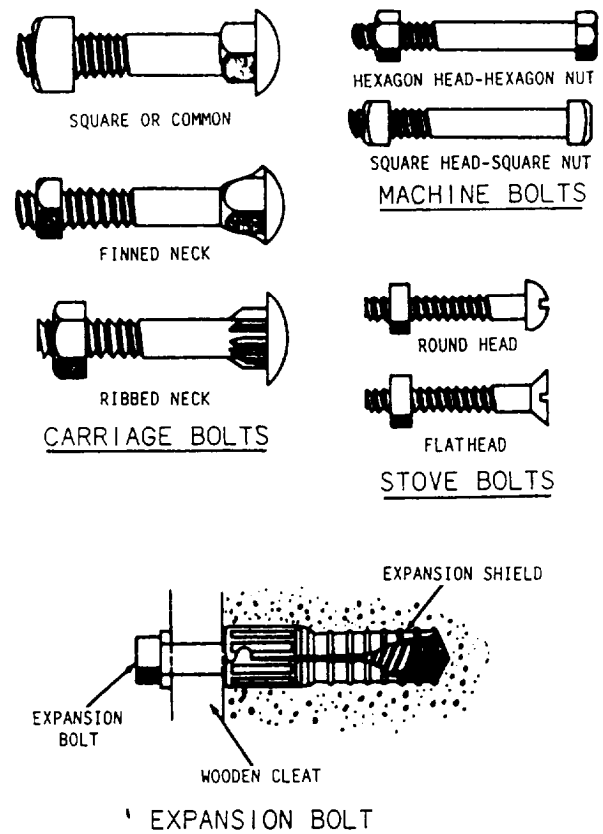

Figure 6-85. Types of bolts.

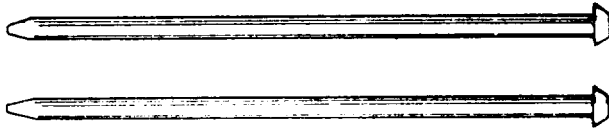

Figure 6-86.-Driftpins (driftbolts).

Driftpins (driftbolts) (fig. 6-86) are long, heavy, threadless bolts used to hold heavy pieces of timber together. Corrugated fasteners (fig. 6-87) are used in a number of ways; for example, to fasten joints (miter) and splices together and as a substitute for nails where nails may split the timber.

Glue

Glue, one of the oldest materials for fastening, if applied properly, will form a joint that is stronger than the wood itself. Probably one of the best types of glue for joint work and furniture construction is animal glue, made from hides. Other types of glue are extracted from fish, vegetables, casein, plastic resin, and blood albumin. Glue can be obtained commercially in a variety of forms—liquid, ground, chipped, flaked, powdered, or formed into sticks.

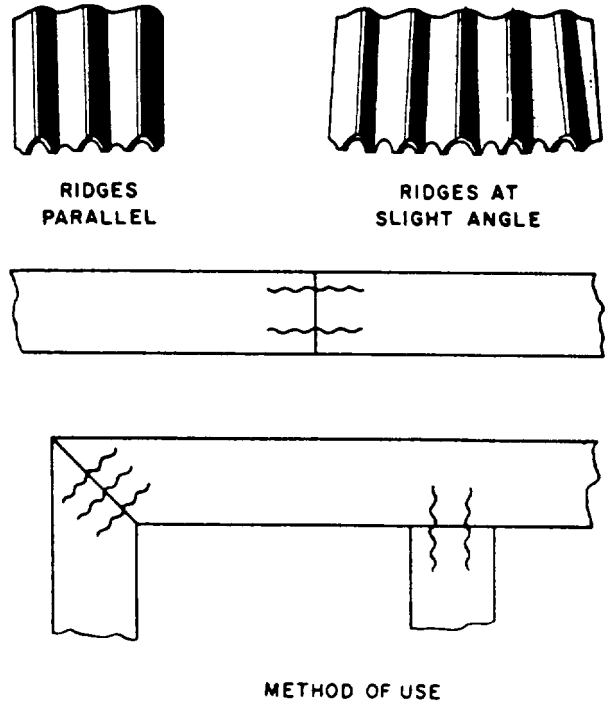

Figure 6-87.-Use of corrugated fasteners.