



Online Continuing Education for Professional Engineers
Since 2009

Fundamentals of Pump Station and Force Main Design

PDH Credits:

4 PDH

Course No.:

PSF101

Publication Source:

Original Courseware

by Donald W. Parnell, PE

“Fundamentals of Pump Station and Force Main Design”

DISCLAIMER:

All course materials available on this website are not to be construed as a representation or warranty on the part of Online-PDH, or other persons and/or organizations named herein. All course literature is for reference purposes only, and should not be used as a substitute for competent, professional engineering council. Use or application of any information herein, should be done so at the discretion of a licensed professional engineer in that given field of expertise. Any person(s) making use of this information, herein, does so at their own risk and assumes any and all liabilities arising therefrom.

Fundamentals of Pump Station and Force Main Design



Introduction



Purpose And Scope

This course provides guidance, instructions and criteria for the design of sanitary and industrial wastewater pumping facilities.

This course is based on a publication which was initially created for Corp of Engineer based pump station and force main design. It has been modified for presentation as a more generalized overview of the subject matter.



Types of Pump Station Facilities

The types of pump station facilities which are covered in this course include pump and ejector stations which are used for the following purposes.

- For the removal of sanitary and industrial wastes from remote or low lying which cannot be served hydraulically by gravity sewers
- Controlled introduction and lifting of raw wastewater into the waste treatment plant
- Transfer of recycled and bypassed flows throughout the plant
- Discharge of treated effluent



Design Aspects of a WW Pumping Station

The design of a wastewater pumping station will typically include:

Civil and Structural aspects - site improvements, structures

Electrical/Mechanical aspects - mechanical and electrical components, system controls and instrumentation, screening and flow monitoring devices

Piping aspects - pumping units, pump drives, interior piping, underground force mains, valves and appurtenances



Special Waste Conditions

Pumping systems for hazardous and explosive wastes, corrosive acids or alkalis, high temperature or other industrial type wastes, generally require the selection of highly resistant pumps, valves and piping materials.

Design of these systems should be in accordance with special criteria developed for each particular situation.



Selection of Materials

The selection of types of materials used for pumps, piping, valves and controls, etc., will be based on manufacturers' recommendations, product specifications, and any other appropriate design manuals or applicable criteria.



Pump Station Choices

Pumping stations and pneumatic ejectors – will normally be required to remove wastes from areas which cannot be served hydraulically by gravity sewers.

Gravity sewer systems - can be used In certain situations, but only at the expense of deep trench excavation, jacking, boring, tunneling, or construction of long sewer runs to avoid high terrain.

Combination gravity and pump - In some cases, both wastewater pumping and gravity flow sewers will be technically feasible and capable of meeting service requirements. However, they may not be equivalent in economic terms.



Using Life Cycle Cost Comparison

When it is not readily apparent which solution would be more economical, the decision to use one or the other will be based on a life cycle cost analysis.

Initial capital and construction costs - for pumps, ejectors, structures, force mains, etc., plus operation and maintenance costs, will be compared with the costs of deep trench excavation, or other special construction methods required for a gravity system.

Generally, a gravity sewer system is justified until its cost exceeds the cost of a pumped system by 10 percent.



Grinder Pumps And Vacuum Systems

There may be areas so limited by high groundwater, subsurface rock, unstable soil or steep topography, that neither gravity sewers nor centralized pumping stations will be feasible.

In these cases, the use of grinder pumps (see image) or vacuum systems should be investigated.

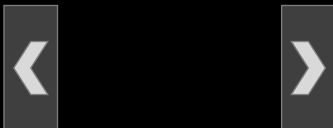

Siting Considerations for Pumping Stations



When are Pump Stations needed

Based on topography - The requirement that an area be served by a wastewater pumping facility, will in most cases be determined by the topography of the area and the need to provide for future development.

Building and grade elevations in the area generally will be too low for proper gravity drainage to an existing or proposed sewer system, or waste treatment facility. Thus, collection and pumping of wastes from these low lying areas will be necessary.

Other considerations - In addition to topographic considerations, natural boundaries like waterways, rivers, streams, etc., and property lines of Federal, state and local jurisdictions, also play a role in determining the size and limits of service areas.



Site Considerations

Pump stations will be located so that all points within the intended service area can be drained adequately by gravity sewers.

Any planned development within the service area, such as construction of new buildings or modifications to existing ones, or any projected shifts in population and/or workforce will be considered.

It is a relatively simple matter to design a pumping station with the capacity for future development, by providing room for additional or larger pumps, motors, impellers, etc. However, the physical location of the station is more critical since it cannot be moved to accommodate new buildings or population increases.



Guidelines for Siting of Pump Stations

The following general guidelines for site selection and location of pumping stations should be used:

Guideline 1- Pumping facilities should not be constructed beneath buildings, streets, roadways, railroads, aircraft aprons or runways, or other major surface structures, to the maximum extent practical.

Guideline 2 - The location of pumping stations should be made with proper consideration given to the availability of required utilities such as electric power, potable water, fire protection, gas, steam and telephone service.



Guidelines (continued)

Guideline 3 - Pump stations will not be located closer than 500 feet to buildings, or other facilities to be occupied by humans, unless adequate measures are provided for odor and gas control.

Guideline 4 - Pumping stations at wastewater treatment facilities will normally be located adjacent to, or in connection with, other plant elements as required for proper functioning of the treatment systems.



Building And Site Requirements - Floor And Building Elevations

Invert elevations - the invert elevations of incoming sewers will determine the depths of underground portions (substructure) of the pumping station.

Maximum liquid level - it is common practice to set the maximum liquid level in the wet well equal to the 80-90 percent flow depth of the lowest incoming sewer.



Elevations

Subsurface and soil conditions - at the site will dictate the structural design, excavation depths, and top of footing elevations required for the foundation.

Surface conditions - such as adjacent buildings and site grading will determine the elevations of floors above ground (superstructure), except that the elevation of the ground floor will be set above the maximum expected flood level.



Building Appearance

Populated areas - For pumping stations located in built-up areas, the architectural exterior of the buildings should be made similar to, or compatible with, surrounding buildings.

Remote areas - When the station is located in a remote area, building appearance is not important, but the possibility of future development in the vicinity will be considered.





Surrounding Appearance

Fencing - pump stations and facilities will be provided with fencing where necessary to prevent vandalism, and to protect people from hazardous contact with electrical transformers and switching equipment.

Landscaping - should be considered in built-up areas, and will be required in residential communities.

Where stations must be constructed in close proximity to residences or other quarters, buffer zones of planted shrubbery should be provided for noise reduction.



Building Access

All pump stations should be readily accessible from an improved road.

Not enclosed - For stations that are not enclosed, access will be provided for direct maintenance from a truck equipped with hoist attachments.

Enclosed – for these stations, provisions should be included in the structure to facilitate access for repair, and to provide a means for removal and loading of equipment onto a truck.



Type And Capacity Of Pumping Stations



Required Pumping Capacity

Proper selection of the number and capacity of pumping units, depends on the quantity and variation of wastewater flows to be handled.

Except as indicated for small stations (on the page for “Small Stations”), pumping units will be selected to handle the normal daily range of wastewater flows generated in the service area.

The number and capacity of pumps provided will need to be sufficient to discharge the minimum, average, peak daily and extreme peak flowrates.

Pumping capacity will be adequate to discharge the peak flowrates with the largest pump out of service.

Specifications for pumps utilized for treatment plant processes, recycling and bypassing of flows, etc., will be based on criteria specific to those types of systems.



Future Pumping Needs

Consideration should be given to future conditions which may occur during the life of the station.

Normally, where future development and population increases are projected for the area, pumps will be designed for initial conditions only, and the station will be provided with adequate room for expansion of pumping capacity at a later date.



Expansion of Pumping Capacity

The expansion of pumping capacity can be accomplished with the installation of additional pumping units, larger pumps, impellers, drive units, adjustable or variable speed drives.

However, some situations may warrant the provision of capacity for future increases initially, for economics or other reasons. Each situation should be analyzed on a case by case basis.





Small Stations

Two identical pumping units will be provided for those pumping stations which are required for small remote areas generating extreme peak flowrates of less than 700 gpm, and where the possibility of future expansion is unlikely, and grinder pump installations serve three or more buildings.

Each pumping unit will be of the constant speed type, and will be capable of discharging the extreme peak wastewater flowrate. The station will be designed to alternate between zero discharge and peak discharge.

This arrangement will provide 100 percent standby capacity to allow for necessary maintenance and repairs. Pneumatic ejector stations will be provided with duplex ejectors each sized for the extreme peak flowrate.





Large Stations

Pumping stations serving large areas of the installation, and especially stations where the entire wastewater flow or major portions thereof must be pumped to the treatment facility, will be designed to operate on a continuous basis.

The pump rate must change in increments as the inflow to the station varies.

This mode of operation will normally require two or more wastewater pumps of the constant or variable speed type, operating in single or multiple pump combinations, as required to match the incoming flowrates.



Type Of Construction

A classification of pumping stations by capacity and the method of construction normally utilized for that capacity is provided in Table 3-1.

Table 3-1. Classification of pumping stations.

Range Class/Type	Recommended Capacity Gallons Per Minute
Factory Assembled (Package Type)	
Pneumatic Ejectors	30-200
Wet Pit Submersible Pumps	100-500
Dry Pit Pumps	100-2,000
Conventional Field Erected	
Small	300-1,500
Intermediate	1,500-10,000
Large	over 10,000

Note: Package type, dry pit pump stations in the capacities shown are generally available off-the-shelf. However, station capacities up to 5,000 gallons per minute can be obtained by special order.





Package type stations

Factory assembled pumping stations, commonly referred to as package type stations, are manufactured in standard sizes and are shipped from the factory in modules with all equipment and components mounted, installed, and ready for connection.

This type of station is suitable for low flows, and where the need to protect pumps from clogging is minimal.



Field-constructed Pumping Stations

Conventional field erected pumping stations are designed for a particular location and to meet specific requirements.

Field constructed stations will be used where the quantity of flow or its variation, or both, exceeds the capacity of available factory assembled stations, or where site conditions require the use of special designs or construction methods.



Wastewater Pumping Equipment



Wastewater Pumps - Centrifugal Pumps

The centrifugal pump is the predominate type of wastewater pump used.

These pumps are available in three variations:

- Radial flow
- Mixed flow
- Axial flow

Centrifugal pumps will not be used in capacities of less than 100 gallons per minute.



Radial Flow Pumps

The radial flow centrifugal pump is the major type used for pumping raw wastes. In a radial flow pump, the fluid enters the impeller axially and is discharged at right angles to the shaft.

Two types of radial flow pumps are available, single suction and double suction:

Single-end suction pump - fluid enters the impeller from one side. The shaft does not extend into the suction passage, and because of this, rags and trash do not clog the pump. The single-end suction pump will be suitable for handling untreated wastewater.

Double suction pump - fluid enters the impeller from both sides, however the shaft extends into the suction passage, thereby limiting its use to handling only clear water.





Sizes of Radial Flow Centrifugal Pumps

Radial flow centrifugal pumps are available in discharge sizes of 2 to 20 inches. However, pumps with a capacity to pass 3-inch minimum solids will be required.

The recommended capacity range for these pumps is 100 to 20,000 gpm. Pumps are available in discharge heads of 25 to 200 feet total dynamic head (TDH).

Peak design efficiency ranges from 60 percent for smaller pumps to 85 percent for larger pumps. Radial flow pumps are suitable for either wet well or dry well applications. They can be installed with horizontal or vertical shafting, however, vertical shaft pumps require considerably less space.



Mixed Flow Pumps

The mixed flow centrifugal pump is an intermediate design between the radial flow type and the axial flow type, and has operating characteristics of both. The mixed flow pump is designed with wide unobstructed passages, and is therefore suitable for handling wastewater or clear water.

Mixed flow centrifugal pumps are available in 8 inch through 84 inch discharge sizes. The recommended capacity range for these pumps is 1,000 to 80,000 gpm. Pumps are available to operate at 10 to 60 feet TDH.

Peak design efficiency - depends on the size and characteristics of the individual pump, but generally ranges from 80 to 90 percent. The mixed flow centrifugal pump is normally used only in dry well applications, with either horizontal or vertical shafting configuration.



Axial Flow Pumps

Axial flow centrifugal pumps appropriate for pumping raw untreated wastewater. This pump is designed primarily for clear water service and for wet well installations. The pump is furnished with vertical shaft having a bottom suction, with the propeller mounted near the bottom of the shaft and enclosed in a bowl.

The propeller is totally submerged and can be easily clogged by large solids, rags or trash. Therefore, this pump will only be used for clear well applications.

Axial flow centrifugal pumps are available in 8-inch through 72-inch discharge sizes. The recommended capacity range for these pumps is 500 to 100,000 gpm. Pumps are available to operate from 1 to 40 feet TDH.



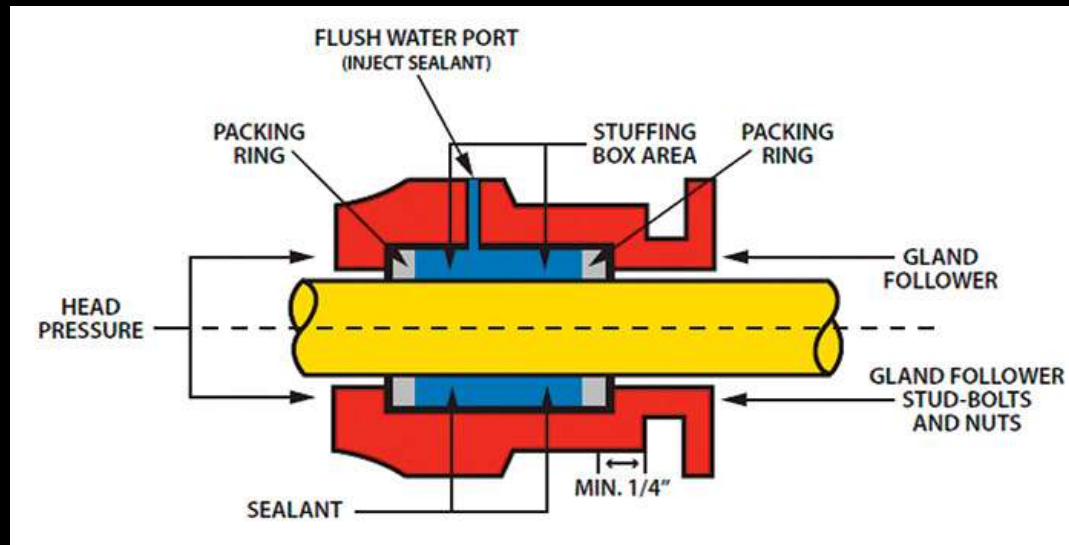

Pump Construction

Centrifugal wastewater pumps will normally be constructed of cast iron with bronze or stainless steel trim, and with either cast iron or bronze impellers.

When wastewater contains substantial quantities of grit, impellers made of bronze, cast steel or stainless steel will be required.

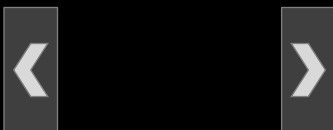

Enclosed Impellers

Enclosed impellers will be specified for wastewater pumps required to pass solids. Pump casings of the volute type will be used for pumping raw untreated wastes and wastewaters containing solids.

Diffusion of turbine type casings may be utilized for effluent or clear water service at waste treatment facilities.



Pump Shafts

Pump shafts will be high grade forged steel, and will be protected by renewable bronze or stainless steel sleeves where the shaft passes through the stuffing box.

Stuffing boxes will utilize either packing glands or mechanical type seals.



Stuffing Box

The stuffing box will be lubricated and sealed against leakage of wastewater (into the box) by grease, potable water, or another clear fluid.

The lubricating and sealing medium will be supplied to the stuffing box at a pressure of 5 to 10 psi greater than the pump shutoff head.



Grease Seals

Grease seals are usually provided by cartridges which are either spring loaded or pressurized by connections off the pump discharge. These arrangements generally do not maintain sufficient seal pressure on the stuffing box.

However, they will be acceptable for low head pumps and where the wastewater contains little grit, as when pumping treated effluent.



Potable Water Seal System

When pumping raw untreated wastes containing the usual quantities of grit, a potable water seal system with seal pump will be required if a potable water line is assessable within a reasonable distance.

The later seal system should be capable of supplying 3 gpm per pump minimum.

The principal advantage of a water seal over a grease seal is the positive pressure maintained on the stuffing box by the seal pump, and small amount of water which flows from the stuffing box into the pump casing.

Grit and other abrasive materials that may be in the wastewater are thereby prevented from entering the stuffing box, thus reducing wear on the shaft and packing.



Potable Water Seal System (continued)

The advantage of less frequent repairs to the shaft and less frequent repacking should be considered in relationship to the cost of providing the water line and other necessary facilities for the water seal.

Where freezing of seal water is likely to occur, protective measures will be taken. There must not be, under any circumstances, a direct connection between wastewater pumps and the potable water system, nor any possibility of backflow of wastes into the potable water system.





Screw Pumps

The screw pump is classified as a positive displacement pump, and as such, maintains two distinct advantages over centrifugal pumps.

It can pass large solids without clogging, and can operate over a wide range of flows with relatively good efficiencies.

Screw pumps are normally available in capacities ranging from 150 to 50,000 gpm with a maximum lift of 30 feet.



Screw Pumps (continued)

Because of its non-clog capabilities and wide pumping range, the screw pump is best suited for lifting raw untreated wastewater into the treatment facility, and for the pumping of treated effluent.

Also, when treatment plants are upgraded, screw pumps may be installed to overcome the additional head losses created by new treatment units, so that existing discharge facilities can be retained.

Screw pumps are usually driven by a constant speed motor with gear reducer, and are inclined at angles of 30 to 38 degrees from the horizontal.

In most instances, screw pumps will be installed outdoors with only the drive unit enclosed.



Pneumatic Ejector

Pneumatic ejector stations will generally be used only in remote areas where quantities of wastes are small, and where future increases in waste flows are projected to be minimal.

A pneumatic ejector (see image) consists of a receiving tank, inlet and outlet check valves, air supply, and liquid level sensors.



Pneumatic Ejector (continued)

When the wastewater reaches a preset level in the receiver, air is forced in ejecting the wastewater.

When the discharge cycle is complete, the air is shut off and wastewater flows through the inlet into the receiver.

Generally, duplex ejectors operate on a 1-minute cycle, filling for 30 seconds and discharging for 30 seconds.

Thus, each receiver tank will be equal in volume to 30 seconds of the extreme peak flowrate. Pneumatic ejector stations are available in capacities ranging from 30 to 200 gpm with recommended operating heads up to 60 feet TDH.

A typical ejector installation will include duplex units with two compressors, receivers, level sensors, etc.



Grinder Pumps

Grinder pumps shred solids normally found in domestic wastewater, including rags, paper and plastic, into a slurry.

The slurry can be pumped under low head through pressure sewers as small as 1¼ inches in diameter.

Grinder pumps are for submersible installation, with a recommended operating range of 10 to 100 gpm.

These pumps are available in discharge heads of 10 to 150 feet TDH.

The peak design efficiency is generally very low.

Grinder pumps will be used only to handle domestic type wastes from one or more individual buildings, and only in remote areas or areas where gravity sewers and centralized pumping facilities are not feasible.



Types of Pump Drives



Electric Motors

As a general rule, electric motors will be provided as the primary drive unit in sanitary and industrial wastewater pumping stations.

Small pump stations serving remote areas where electric power is not available, will usually require engine drives.

The three types of electric motors most commonly used in wastewater pumping are:

- 1) squirrel cage induction
- 2) wound-rotor induction
- 3) synchronous



Squirrel-cage Induction Motors

Squirrel-cage induction motors (see image) will normally be selected for constant speed pump applications because of their simplicity, reliability and economy.

They can also be used for variable speed operation when provided with the proper speed control.

Synchronous motors - may be more economical for large capacity, low rpm, constant speed pumps.





Wound-rotor Induction Motors

Wound-rotor induction motors are most commonly used for pumps requiring variable speed operation.

For a 60 cycle, alternating current power supply, the maximum synchronous motor speed allowed for wastewater pumps will be 1800 rpm (approximately 1770 rpm induction speed).

The normal range of speeds is from 600 to 1200 rpm, with speeds below 450 rpm unusual at military installations.

Lower speed pumps and motors are larger and more expensive, but generally are more reliable.



Selection of Electric Motors

The selection of electric motors will depend upon the type, size and location of the pumps, type of speed control used, and the power available at the site. Pump location will determine the type of motor enclosure.

For Dry pit pump installs - motor enclosures will normally be the open, drip proof type.

Outdoor dirty or corrosive environments - will require totally enclosed motors. Submersible pumps will have motor enclosures which are watertight.

Motors installed outdoors will have temperature ratings adjusted to suit ambient operating conditions.

For pumps designed to operate on an intermittent basis, space heaters will be provided in motor housings to prevent condensation. Motors installed in wet wells will be explosion proof.



Motor Starting Equipment

Motor starting equipment will be suitable for the type of motor required voltage. Motor starters will be designed for limiting the inrush current where shocks or disruptions to the electrical supply are likely to occur as a result of pump start-up.

Where low starting inrush current is required for constant speed pumps, such as when using engine driven generator sets, wound-rotor motors will be considered as an alternative to squirrel-cage motors.



Pump Drives - Internal Combustion Engines

(IC) Internal combustion engines will be used primarily at large pumping stations where electric motors are the primary drive units, and where emergency standby facilities are required.

Internal combustion engines are required for small pump stations in remote locations where no electric power source exists.



At large wastewater treatment plants

At large wastewater treatment plants where abundant digester gas is produced, it will generally be more feasible to use IC engines which are fueled by the waste gas.

IC engines may be arranged to drive horizontal pumps by direct or belt connections, or they may drive vertical pumps through a right angle gear drive with an electric motor as the primary drive unit (dual drive).

It is more common however, and will be the general rule at large pump stations, to provide fixed emergency generator sets powered by IC engines.



IC Powered Generators

Generators produce electric power not only for pumps, but also for auxiliary equipment such as heaters, lights, alarms, etc., and for critical pump control systems.

The types of internal combustion engines normally used include:

- 1) diesel
- 2) gasoline
- 3) natural gas, primarily digester gas
- 4) dual-fuel diesel



Fuel Types

Gasoline engines - for anything except small, remotely located pumping stations is not recommended due to the hazards associated with fuel handling and storage.

Dual-fuel diesel engines - fire a mixture of diesel oil and natural gas, with a minimum of 10 percent diesel fuel required to ignite the mixture.

Propane - is usually provided as a backup fuel for gas and dual-fuel diesel units.



Drive Mechanisms



Direct Drive

Direct drive, with the shaft of the drive unit directly connected to the pump shaft, is the most common configuration. This connection can be either close-coupled or flexible-coupled.

When using a close-coupled connection, the pump is mounted directly on the drive shaft. This is the normal arrangement for a vertical pump driven by an electric motor.

A horizontal pump will usually have a flexible connection, with the engine mounted adjacent to the pump.

A vertical motor mounted above, and at a distance from a vertical pump, will be connected to the pump with one or more lengths of flexible shafting.

Direct drive offers the most efficient operation because no power is lost between the drive unit and the pump.



Belt Drives

Belt drives may be utilized if the pump speed is different from those available with standard drive units, or if speed adjustment is required.

Speed adjustment is accomplished by changing pulley or sheave ratios.

Belt drives used with horizontal pumps require more floor space than a direct drive unit.

There is power loss through the belt, which results in lower efficiency, and belt wear increases maintenance requirements.

Belt drives will be used only when it is not possible to choose single speed equipment to cover service conditions, or where pump speed adjustments may be required, but variable speed operation is not.



Right Angle Drives

Right angle drives (see image) will be used on vertical pumps being driven by horizontal engines.

If the engine serves as emergency standby, a combination gear box will be installed on the angle drive to allow operation of the pump by the primary drive unit, which is normally an electric motor.

A clutch or disconnect coupling disengages the right angle gear when the motor drives the pump.

When the engine drives the pump, the clutch is engaged and the motor rotates freely.

In case of a power failure the engine is automatically started, and after reaching partial operating speed is engaged to drive the pump.



Pump Speed Controls



Mode of Operation

Wastewater pumps will be designed to operate in one of the following modes:

- 1) constant speed
- 2) adjustable speed
- 3) variable speed

The type of speed control system will be selected accordingly, and the type of speed control required will influence the type of electric motor to be used.



Constant Speed

Constant speed drive is the simplest, most reliable, and most economical mode of operation, and will be suitable for the majority of wastewater pumping applications at military installations.

However, where there is a need to match pumping rates with the incoming wastewater flowrates, a variable speed drive will usually be more appropriate.



Adjustable Speed

By changing pulley or sprocket ratios on a belt driven pump, the speeds can be adjusted to accommodate several constant speed pumping rates.

This type of system will be used mainly in sludge pumping, but can be a good alternative to variable speed control in wastewater pumping when speed adjustment is not required too often.

Where automatic operation is needed pulleys or sheaves can be positioned through the use of pneumatic, hydraulic or electric devices.



Variable Speed

Variable speed operation will usually be required at large pumping stations where the entire wastewater flow, or major portions thereof, must be pumped to the treatment facility, and where it is desired to match the incoming flowrates in order to maintain a smooth, continuous flow into the plant.



Constant vs Variable

Pumping stations will normally require more pumps under a constant speed system than one utilizing variable speeds.

Also, the size of the wet well can be reduced greatly when pumps operate on a continuous basis.

Variable speed operation is less efficient than constant speed when pumping at reduced rates, however friction losses and thus power costs are generally less for the smaller flows.



Selection and Design of the Speed Control System

The selection and design of the speed control system will be coordinated closely with the selection of the pump and drive units.

The simplest system which allows pumps to accomplish the required hydraulic effects will be chosen for design.

Factors to be considered in selecting a system include cost, efficiency, reliability, structural requirements, ease of operation and degree of maintenance necessary.

Pumping stations will normally be designed for automatic on/off operation of the pumping units, with manual override by pushbutton or selector switch.



Automatic Speed Control Systems

Most automatic constant speed and adjustable speed systems will operate from level signals.

Pumps are turned on as the liquid level in the wet well rises, and are turned off when it falls.



Sensor Systems



Sensor Types

Pumping systems utilized in treatment plant processes are sometimes controlled by flow or pressure sensors.

Level detection systems in standard use include the following:

- 1) Float Switches
- 2) Mercury Switches
- 3) Bubbler Tube
- 4) Electrodes
- 5) Sonic Meters

The capacitance tube and pressure diaphragm sensor types of controls will not normally be used due to fouling by the wastes.



Float Switches

The simplest type of switch consists of a float attached to a rod or tape, and suspended in the wet well.

The float rod opens or closes a switch, depending on the rise or fall of the float riding on the liquid level.

The float may also be suspended in a tube or cage.

These units usually require frequent maintenance as grease, scum and debris in the wastewater build up on the equipment.





Mercury Switch

Another type of float control incorporates a mercury switch encapsulated in a corrosion resistant ball, and suspended by cable in the wet well.

This unit is not dependent upon the smooth, vertical movement of a rod, and thus is not subject to the maintenance problems described on the previous page.



Bubbler Tube

One of the most commonly used systems employs a bubbler tube which is suspended in the wet well and is fed by compressed air.

The backpressure on the open end of the tube is sensed by pressure switches, and then transduced to a voltage or current signal.

These signals are transmitted to a controller which operates the pumps.

This system has no moving parts in contact with the wastewater, and requires very little maintenance.

The constant flow of compressed air keeps the tube free of solids accumulations.



Electrodes

A series of electrodes are mounted at different elevations so that when the liquid level rises and contacts an electrode, an electric circuit is energized.

Electrodes are used primarily in pneumatic ejectors where the compressed air serves to keep the electrodes clean.

They will not normally be used in wet wells due to frequent fouling by grease and waste debris.



Sonic Meters

A sonic meter measures the distance from the liquid level to the meter. They are difficult to install free of obstructions, and must be isolated from stray electrical or acoustic signals.



Speed Control Devices



Bubbler System

A bubbler system will in most cases be employed to control the operation of automatic variable speed pumps.

In these systems, the backpressure from the bubbler tube is transduced to a pneumatic or electronic signal for use in on/off and variable speed control of the pumps.

On/ off controls are usually provided by pressure or electronic switches.



Variable Speed Control Devices

Variable speed control devices consist of:

- 1) magnetic (eddy current) clutches
- 2) liquid clutches
- 3) variable voltage controls
- 4) variable frequency controls
- 5) wound-rotor motor controls

In general, variable speed control devices are more expensive, less efficient, and require a higher degree of maintenance than constant speed controls.



Magnetic and Liquid Clutches

Magnetic and liquid clutches have been available for many years as controllers for variable speed pumps.

These older methods are inefficient in that the slip losses which developed are lost as heat.

The recent development of solid state electronics has led to the introduction of newer methods of variable speed control suitable for both squirrel-cage and wound-rotor induction motors.



Variable Voltage and Variable Frequency Controls

The variable voltage and variable frequency controls are suitable for use with squirrel-cage motors.

Variable frequency drives are possible in efficiencies up to 95 percent, and are available in sizes up to 250 hp. However, variable voltage units are inefficient and are not recommended.



Wound-rotor motor controls

Wound-rotor motor controls come in five categories:

- 1) fixed step resistors
- 2) liquid rheostats
- 3) reactance/resistance controllers
- 4) electronic rheostats
- 5) regenerative secondary controls

Of these, the regenerative secondary control offers the best efficiency, while the other units are considerably less efficient and require more maintenance.



Force Mains



Force Mains

The pipeline which receives wastewater from a pumping station, and conveys it to the point of discharge, is called a force main.

Force mains are designed as pressure pipe, and must be adequate in strength to withstand an internal operating pressure equal to the pump discharge head, plus an allowance for transient pressures caused by water hammer.



Pipe Selection

The internal operating pressure is maximum at the pumping station, and is reduced by friction to atmospheric, or near atmospheric, at the point of force main discharge.

The primary consideration in the hydraulic design of force mains is to select a pipe size which will provide the required minimum velocities without creating excessive energy losses due to pipe friction.



Pipe Size

The most economical size of force main should be determined on the basis of power costs required for pumping, and capital investment costs of piping and equipment.

In practice however, the size is usually governed by the need to maintain minimum velocities at low flows to prevent deposition of solids, and to develop sufficient velocity at least once a day to resuspend any solids which may have settled in the line.

However, regardless of pipe sizes required for minimum velocities, the minimum diameters to be used are 14-inch for pressure sewers at grinder pump installations, 4-inch for force mains serving small pump stations and pneumatic ejectors, and 6-inch for all other force mains.



$$V = 1.32 C R^{0.63} S^{0.54}$$

where

V = velocity in feet per second

C = coefficient of pipe roughness

R = hydraulic radius in feet, and

S = slope of energy grade line in feet per foot

Force Main Hydraulics - Design Formula

Force mains will be designed hydraulically with the use of the Hazen-Williams following formula (shown above.)



Hazen-Williams Chart

Force mains may also be designed hydraulically with the use of the Hazen-Williams chart to the right.

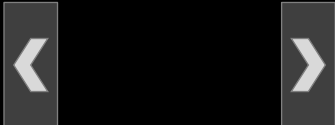
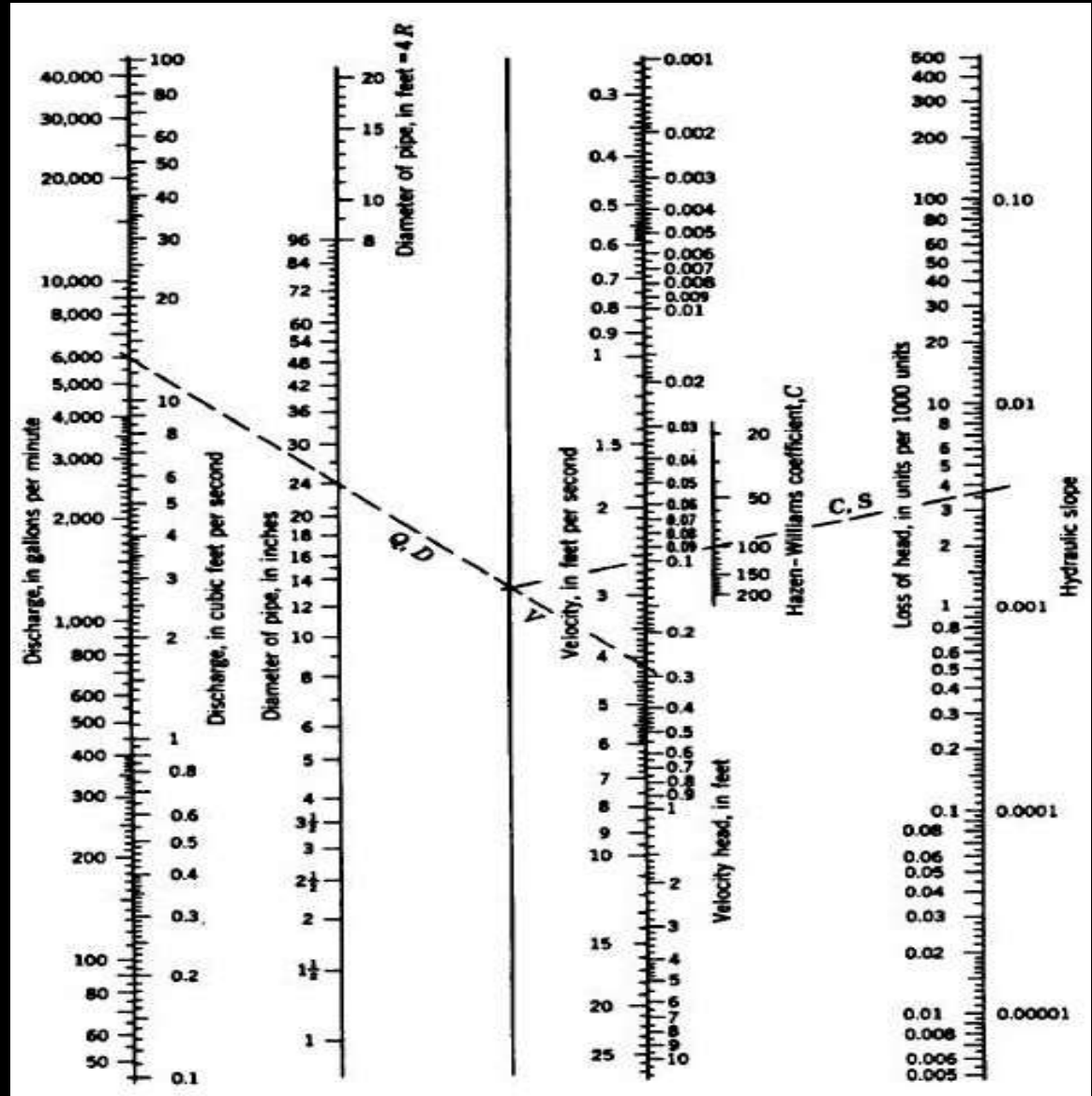

Roughness Coefficient

Values of C to be used in the formula range from 100 for older force mains which have been in service a number of years (usually over 10), to 140 for force mains which are newly constructed.

Some manufacturers of plastic and asbestos-cement pipe report C values as high as 150.

However, due to uncertainties in design and construction, plus a desire to provide a margin of safety, C values greater than 140 will not normally be permitted.



C Value for Force Mains in Poor Condition

At some installations, force mains may be very old (40 to 50 years) and in extremely bad condition, with offset joints broken pipe, or materials encrusted on pipe walls.

For these cases, lower C values may be justified.

However, values lower than 80 will not be allowed unless verified by flow and pressure tests.



Velocity Criteria

Velocity criteria for force mains are based on the fact that suspended organic solids do not settle out at a velocity of 2.0 foot per second or greater.

Solids will settle at velocities less than 1.0 fps and when wastewater pumps are idle.

However, a velocity of 2.5 to 3.5 fps is generally adequate to resuspend and flush the solids from the line.



Small Station - Force Main Velocities

Force mains serving small pump stations, which are designed to operate on an intermittent basis, will be sized to provide a minimum velocity of 3.5 fps at the peak discharge rate.

For small stations having flows too low to warrant a minimum velocity of 3.5 fps with one pump operating, the design may call for both pumps to be operated manually once a week for a sufficient period of time to flush out the line.



Large Station - Force Main Velocities

Larger stations having three or more pumping units - which operate a major portion of the time, will require minimum force main velocities ranging from 2.0 fps with one pump operating, to 5.0 fps with several pumps operating.

In these cases, it is only required that a minimum velocity of 2.5 to 3.5 fps be provided once or twice daily.

Large pumping stations which serve the entire installation - or major portions thereof, and which are designed to pump continuously, will usually have a greater number of pumps operating over a wider range of flowrates.

Since the pumping range may vary from 7 or 8 to 1, it will generally be sufficient to design for velocities of 0.5 up to 7.0 or 8.0 fps. Maximum velocity is set at 10.0 fps.



Value of S (Slope)

The value of S in the formula is equivalent to the kinetic energy loss due to pipe friction divided by the length of conduit, or:

$$S = H_f/L$$

Minor energy losses from fittings and valves will be converted to equivalent lengths of conduit for use in the formula.



Total Kinetic Energy Loss

Conversion tables for fittings and valves can be found in standard hydraulics textbooks.

The total kinetic energy loss in a force main will be computed by multiplying the slope of the energy grade line by the total length of conduit including equivalent lengths, or:

$$H_f = S \times L$$



Pump Analysis And Selection –Total Dynamic Head

The head in feet against which a pump must work when wastewater is being discharged is termed the total dynamic head (TDH).

The two primary components of TDH in wastewater applications are the static discharge head and the kinetic losses due to pipe friction.



TDH - Bernoulli energy equation

Velocity and pressure heads are also present, but are usually insignificant.

The TDH will be calculated with the use of the Bernoulli energy equation which can be written as follows (image to the right)

All head terms are in feet. Subscripts d and s represent force main discharge and pump suction, respectively.

In order to determine hydraulic conditions at the pump suction, it will be necessary to write an energy equation from the liquid level in the wet well to the pump suction nozzle.

$$TDH = (P_d/W + V_d^2/2g + Z_d) - (P_s/W + V_s^2/2g + Z_s) + H_f$$

where

P_d, P_s = gage pressures in pounds per square foot

V_d, V_s = velocities in feet per second

Z_d, Z_s = static elevations in feet

H_f = kinetic energy loss from pipe friction, fittings, and valves, as calculated in [paragraph 5-1b](#) (3).

w = specific weight of fluid in pounds per cubic foot, and

g = acceleration due to gravity 32.2 ft/sec²)



Pump Analysis And Selection



System Head - Capacity Curve

To determine the head required of a pump, or group of pumps, that would discharge at various flowrates into a force main system, a head-capacity curve must be prepared.

This curve is a graphic representation of the total dynamic head, and will be constructed by plotting the TDH over a range of flowrates from zero to the maximum expected value.



Friction Losses

Friction losses can be expected to increase with time, thus affecting the capacity of the pumping units and their operation.

Therefore, system curves will reflect the maximum and minimum friction losses to be expected during the lifetime of the pumping units, as well as high and low wet well levels.



System Curves

The typical set of system curves will generally consist of two curves using a Hazen-Williams coefficient of $C = 100$ (one for maximum and one for minimum static head), and two curves using a Hazen-Williams co-efficient of $C = 140$ (for maximum and minimum static head).

These coefficients represent the extremes normally found in wastewater applications.



Pump Head - Capacity Curve

The head that a particular pump can produce at various flowrates is established in pump tests conducted by the pump manufacturer.

The results of these tests are plotted on a graph to form the pump characteristic curve.

Along with the discharge head developed, the pumps operating efficiency, required power input, and net positive suction head are generally included on the same diagram.



Efficiency And Power Input

Pump efficiency is the ratio of the useful power output to the input, or brake horsepower, and is given by:

$$E = \frac{wQ \text{ TDH}}{(\text{bhp})(550)}$$

where

E = pump efficiency (100 E = percent)

w = specific weight of fluid in pounds per cubic foot

Q = pump capacity in cubic feet per second

TDH = Total dynamic head, and

bhp = brake horsepower



Pump Efficiency

Pump efficiencies usually range from 60 to 85 percent. Most characteristic curves will indicate a best efficiency point (BEP) at which pump operation is most efficient.

Where possible, pumps will be selected to operate within a range of 60 to 120 percent of the BEP.



Net Positive Suction Head

When pumps operate at high speeds and at capacities greater than the BEP, the potential exists for pump cavitation.

Cavitation can reduce pumping capacity and may in time damage the pump impeller.

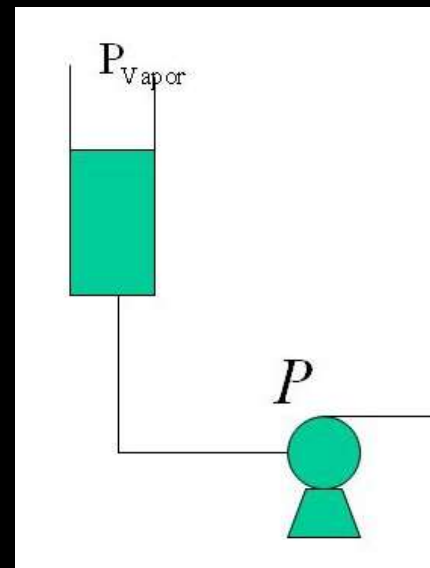



Cavitation

Cavitation occurs when the absolute pressure at the pump inlet drops below the vapor pressure of the fluid being pumped.

To determine if cavitation will be a problem, the net positive suction head (NPSH) available will be computed, and compared with the NPSH required by the pump.



NPSH Formula

The NPSH is not normally a problem when discharge heads are less than 60 feet.

However, when heads are greater than 60 feet, or when the pump operates under a suction lift, or far out on its curve, the NPSH will be checked.

The NPSH available at the eye of the impeller in feet will be calculated with the following formula (image to the right.)

Note: All head terms are in feet.

$$NPSH_A = H_8 + P_a/w - P_v/w$$

where

H_8 = total energy head at pump suction nozzle
 $= P_8/w + V^2 / 2g + Z,$

P_a = atmospheric pressure in pounds per square foot absolute, and

P_v = vapor pressure of fluid being pumped in pounds per square foot absolute



Affinity Laws

A set of relationships derived from flow, head and power coefficients for centrifugal pumps, can be used to determine the effect of speed changes on a particular pump.

These relationships are known as affinity laws and are as follows:

$$\begin{aligned}Q_1/Q_2 &= N_1/N_2 \\H_1/H_2 &= N_1^2/N_2^2 \\P_1/P_2 &= N_1^3/N_2^3\end{aligned}$$

where
 N_1, N_2 = pump speeds in revolutions per minute
(rpm)



Variables from the Affinity Laws

Q, H and P terms represent pump capacity, discharge head, and power output respectively, at speeds N_1 and N_2 .

These relationships will be used in analyzing variable speed pump operation in the absence of manufacturer's characteristic curves, or where characteristic curves do not show performance at the desired speeds.



Pump Selection

System analysis for a pumping station will be conducted to select the most suitable pumping units which will meet service requirements, and to determine their operating points, efficiencies, and required horsepower.



Single Pump Operation

A system head capacity curve will be prepared showing all conditions under which the pump is required to operate.

The system curve will then be superimposed onto a pump head-capacity curve, or characteristic curve, to define the pump operating point.



Typical Pump System Curve

The point where the two curves intersect represents the head and capacity at which the pump will operate in the given piping system.

A typical set of system curves with pump characteristic curves is shown in the diagram to the right.

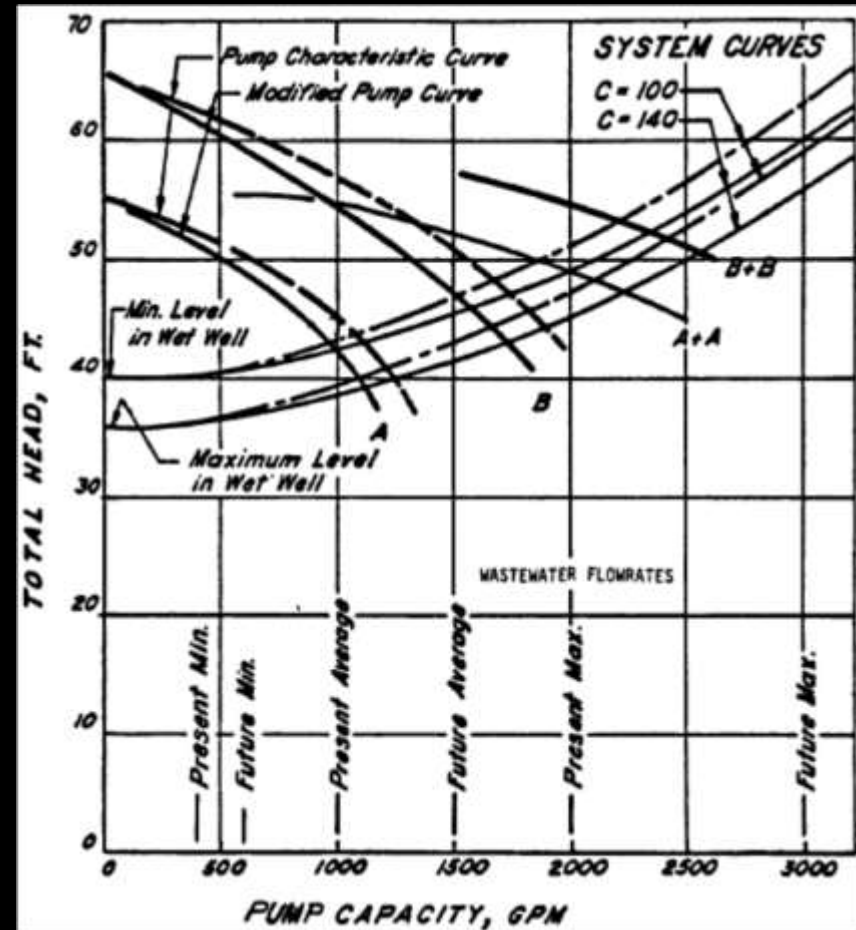



Multiple Pump Operation

Where two or more pumps discharge into a common header, the head losses in individual suction and discharge lines will be omitted from the system head-capacity curve.

This is because the pumping capacity of each unit will vary depending upon which units are in operation.

In order to obtain a true picture of the output from a multiple pump installation, the individual suction and discharge losses are deducted from the pump characteristic curves.

This provides a modified curve which represents pump performance at the point of connection to the discharge header.



Multiple Pump Performance

Multiple pump performance will be determined by adding the capacity for points of equal head from the modified curve.

The intersection of the modified individual and combined pump curves with the system curves shows total discharge capacity for each of the several possible combinations.

Pumps should be selected so that the total required capacity of the pump installation can be delivered with the minimum level in the wet well and maximum friction in the discharge line.

Pump efficiency will be a maximum at average operating conditions.



Design of Wet Wells for the Storage of Pumpage





Wet Well Design

Wet wells will be constructed at pumping stations for the purpose of storing wastewater flows prior to pump operation. The storage volume required depends upon the method of pump operation, i.e., whether pumps are constant, adjustable or variable speed.

In addition to providing adequate storage volume, wet wells will be designed to:

- 1) allow for proper pump and level controls
- 2) maintain sufficient submergence of the pump suction inlet
- 3) prevent excessive deposition of solids
- 4) provide ventilation of incoming sewer gases

In smaller stations, bar racks or comminuting devices may be installed within the wet well in order to reduce costs. Overflows from wet wells are prohibited in all cases.



$$V = tq/4$$

where
 V = required volume in gallons between start and stop elevations for a single pump, or a single speed step increase for adjustable or variable speed operation

t = minimum time in minutes of one pumping cycle (time between successive pump starts), or time required for a speed or capacity change, and
 q = pumping capacity, or increment in capacity where one or more pumps are operating and an additional pump is started, or where pump speed is increased, in gallons per minute

Storage Volume

If pumps are of constant or adjustable speed type, the wet well volume must be large enough to prevent short cycling of pump motors.

For pumps driven by variable speed drives, the storage volume may be small provided pumping rates closely match the incoming flowrates.

The volume (V) required for the wet well will be computed with the above formula:

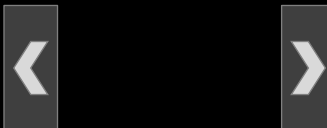

Minimum Pump Cycle Times (Pumps driven by Squirrel Cage Motors)

Constant or adjustable speed pumps driven by squirrel cage induction motors will be designed for minimum cycle times as shown in the following table:

Table 5-1. Minimum pump cycle times.

More size, bhp	t, minutes
Less than 20	10 to 15
20 to 100	15 to 20
100 to 250	20 to 30
Over 250	as recommended by manufacturer



Control Circuit for Alternating Pumps

The storage volume calculated for small stations (capacities less than 700 gpm) which utilize two identical constant speed pumps, may be reduced one half by providing a control circuit to automatically alternate the pumps.

The storage volume required for variable speed pumps will be based on providing sufficient time for a change in capacity when a pump is started or stopped.



Wet Well Storage Retention Time

When a pump is started, the motor must be ramped to the desired speed, and the pumps already in operation must be reduced in speed. The time required for this is usually less than 1 minute.

A considerable amount of storage is normally available in large sewers which serve stations utilizing variable speed pumps. This volume may be considered in design by calculating backwater curves for the various operating levels.

The maximum retention time in the wet well will not exceed 30 minutes to prevent septicity.



Suction Pipe Connections

Pump suction piping will be selected to provide a velocity of 4 to 6 feet per second. Pipe should be one or two sizes larger than the pump suction nozzle.

Vertical pumps installed in a dry well which is adjacent to the wet well, will be fitted with a 90 degree suction elbow, followed by an eccentric reducer and a gate valve.



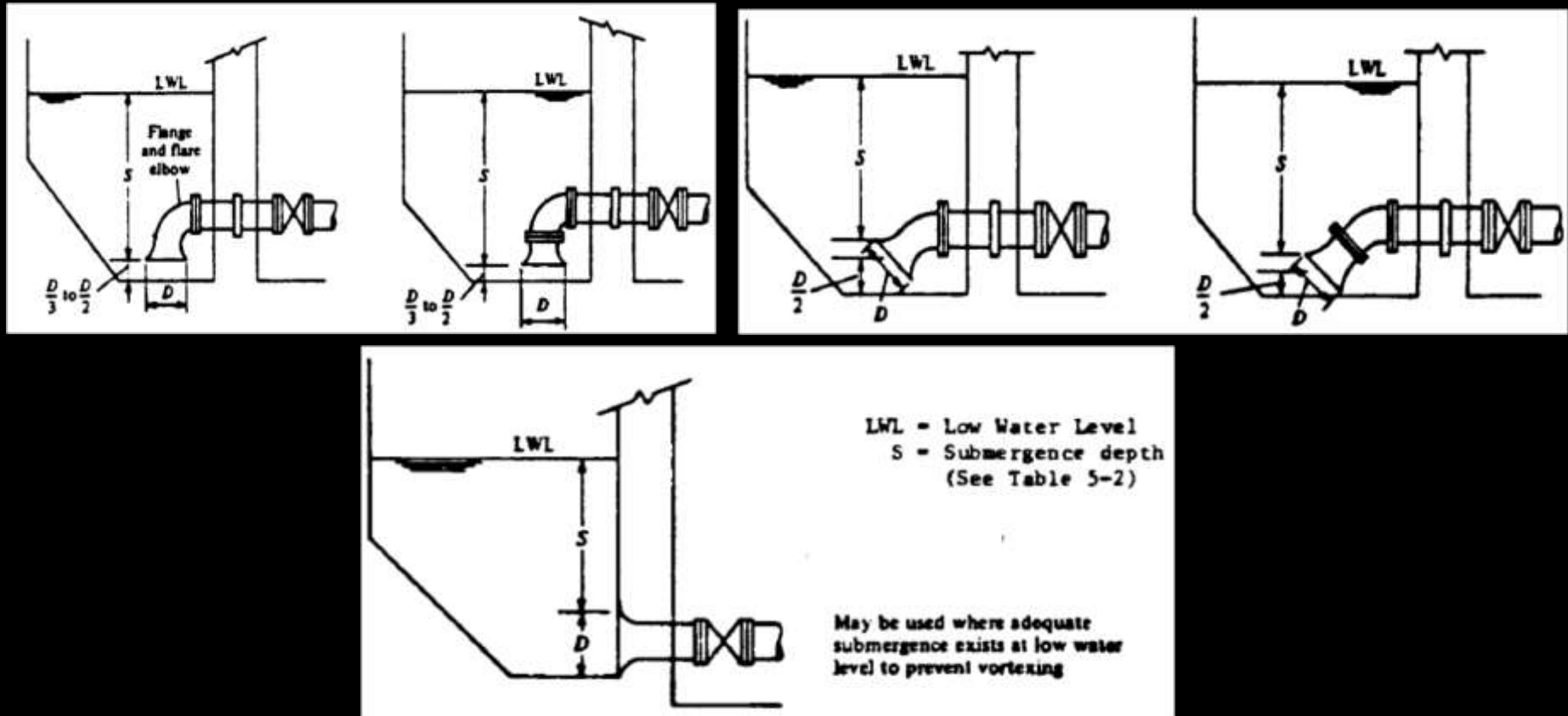

Common Piping Arrangements

The suction line will be extended through the wall into the wet well, and terminated with either a 90 or 45 degree flared elbow, or an elbow with a flared fitting. The most commonly used piping arrangements are illustrated in the images above, where D is the diameter of the flared inlet, and S is the submergence depth.

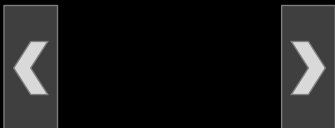

Table 5-2. Required submergence depth to prevent vortexing.

Velocity at diameter D, fps	S, feet
2	1.0
4	2.6
5	3.4
6	4.5
7	5.7
8	7.1

Adequate depth of Submergence to avoid Vortexing

Adequate submergence of the suction inlet is critical to prevent air from being drawn in by vortexing.

Minimum required submergence depths are given in the table above as a function of velocity.

The net positive suction head (NPSH) will also be considered when determining S.



Dividing Wet Wells into Two or More Compartments

Larger, conventional type pump stations will normally be constructed with wet wells divided into two or more sections, or compartments, so that a portion of the station can be taken out of service for inspection or maintenance.

Each compartment will have individual suction pipes, and will be interconnected with slide or sluice gates.



Slope on Floor of Wet Well

The floor of the wet well will be level from the wall to a point 12 to 18 inches beyond the outer edge of the suction bell, and then will be sloped upward at a minimum 1:1 slope.



Pump Controls And Instrumentation



Instrumentation at a Pumping Station

Instrumentation at a pumping station includes automatic and manual controls used to sequence the operation of pumps, and alarms for indicating malfunctions in the pumping system.

Automatic control of pumps will usually be based on the liquid level in the wet well.



Manual Control and System overrides during Emergencies

Manual control of pumps is always required in order to operate the pumps during emergencies, for maintenance purposes, or when automatic systems fail.

Manual overrides will be set to bypass the low level cut-off, but not the low level alarm.



Selection Of Control Points

A control range of at least 3.0 feet is required between maximum and minimum liquid levels in the wet well.

A minimum of 6 inches will be required between pump control points used to start and stop successive pumps, or to change pump speeds.

For small stations, the control range may be less, however control points will not be set closer than 3 inches.



Pump Speed

Constant or adjustable speed pumps - require simple on-off switches to start or stop pumps, or to change from one speed step to the next.

Variable speed pumps - require a more complex control arrangement.

The two basic types of level control for variable speed operation are:

- variable level
- constant level



Variable Level Control for Pump Speed

For variable level control, a narrow band of control points is established in the wet well.

Pump speed is then adjusted in steps by the level detection system (usually a bubbler tube) as the level varies.

Pumps operate at maximum speeds near the HWL, and at minimum speeds near the LWL. However, pumps are started and stopped by level switches.



Constant Level Control for Pump Speed

Constant level control is seldom used, but may be required where a very narrow band of operation is necessary.

In a constant level system, one level is set as the control point, and pump speed is adjusted in a stepless fashion as the liquid level rises above, or falls below this point.





Level Alarms

Alarms will be provided to signal high and low liquid levels in the wet well, pump failure, or a malfunctioning speed control system.

The high level alarm will be set above the start point of the last pump in the operational sequence, but below the start point of the standby pump, if used.

The low level alarm will be set below the shutoff point of the lead pump. An emergency, low level pump cutoff will be set below the low level alarm.



Surge Phenomena (Water Hammer)





Surge Phenomena - Water Hammer in Force Mains

Sudden changes in flow and velocity in force mains can occur as a result of pump startup, pump shutdown, power failure, or rapid closing of a valve.

These velocity changes can produce large pressure increases or surge phenomena known as water hammer, which can cause extensive damage to force mains (see image).

Most severe water hammer conditions - are usually caused by a pump shutdown or power failure. An analysis of water hammer will include calculating the critical time, determining the maximum pressure increase, and selecting a method of control.



Surge Phenomena - Critical Time

When flow is suddenly changed in a force main, a pressure wave is generated which rapidly travels the entire length of conduit, and back to the point of change. The time required for this roundtrip is given by:

$$T_c = 2L/a$$

where

T_c = critical time in seconds

L = length of force main between point of flow change and point of discharge in feet, and

a = velocity of pressure wave in feet per second



When the Time Interval is more than/less than T_c

When flow is completely stopped ($Q = 0$) in a time interval greater than T_c , the maximum theoretical pressure increase is not fully developed.

When flow is stopped in a time interval less than or equal to T_c , the change is said to be instantaneous, and the maximum pressure increase is developed (see next page).



Surge Phenomena-Maximum Pressure Increase

The maximum theoretical pressure increase or surge caused by water hammer is calculated from the following:

$$h_w = aV/g$$

where

h_w	=	pressure increase in feet
V	=	velocity of fluid in the pipeline prior to flow change in feet per second
g	=	acceleration due to gravity, or 32.2 ft/sec ² at sea level, and
a	=	velocity of pressure wave in feet per second



Surge Phenomena-Methods Of Control

Whenever a pump is shut down, or power to the station fails, the pump motor is suddenly cut off.

Pump speed along with flow and velocity in the force main are quickly decelerated by pressure waves, which travel up the pipeline and back in accordance with Newton's second law of motion.



Reversed Flow through Pump

When the velocity is reduced to zero, reverse flow through the pump would occur if a gravity operated check valve or an automatic control valve were not installed on the pump discharge line, and did not close properly.

Reverse flow fully accelerated through the pump could cause transient flows and pressures well above maximum design conditions.



Pressure Surges due to Valve Conditions

A swing check valve which stuck open temporarily, and then slammed shut under these conditions, would result in a large pressure surge as mentioned previously.

In order to control and limit surge phenomena - the following valve applications may be used:



Gravity-operated Check Valves

For simple cases involving small to medium sized pump stations with gradually rising force mains (no intermediate high points) of less than 1000 feet in length, and with static discharge heads of less than 50 feet, a gravity operated check valve will usually be sufficient.

Gravity type check valves may be either swing checks utilizing outside lever and weight (or spring) set to assist closure, or then may be ball checks.

Swing check valves are usually installed horizontally, while ball check valves may be either vertical or horizontal.



Pressure Relief Valves

For additional protection, a pressure relief valve may be installed in conjunction with check valves to allow reversing flow to reenter the wet wall.

Pressure relief valves must be specially designed for sewage applications. As an alternative to relief valves, a hydro-pneumatic tank may be utilized.



Automatic Control Valves

In situations where long force mains are required, pipe profiles must conform to existing ground elevations for economic reasons.

This normally will result in high points in the force main, with the possibility of water column separation at the high points during pump shutdown or power failure.

The pressures generated when these separated columns come to rest against closed valves or against stagnant columns may be large, and are again determined by the conditions previously mentioned.



Automatically Operated Valves

In general, where force mains are greater than 1000 feet in length or contain intermediate high points, and where pumping stations are large in capacity, or static discharge heads are greater than 50 feet, control valves will be automatically operated cone, plug, ball, or butterfly valves.



Valve Closure during Pump Shutdown

Normal operation of these valves upon pump shutdown, is to slowly close the valve while the pump continues to run. When the valve is closed, a limit switch then stops the pump motor. On power failure, an emergency hydraulic or other type operator closes the valve slowly.

The time of valve closure is of utmost importance. Valves should be half closed when the velocity in the force main has dropped to zero.

The time required to reach zero velocity can be calculated with this formula:

$$t = LV/g H_{av}$$

where

t	=	time in seconds
L	=	length of force main in feet
V	=	velocity of fluid in pipeline in feet per second, and
H _{av}	=	average decelerating head including pipe friction in feet



Valve Closure Times

The types of valve operators most often utilized are hydraulic, electric and pneumatic. Valves and operators specified for use will be fully adjustable for closure times ranging from t to $4t$ minimum. In some large pumping stations, the use of automatically controlled valves alone will not be sufficient

Extremely long force mains (over 1 mile) may require very long valve closing times, and thus result in excessive backflow to the wet well and reverse rotation of the pump and motor. To solve these problems, a pump bypass with surge relief valve will generally be required.



Valves used for Surge Relief

Valves used for surge relief will be automatically controlled cone or butterfly valves, similar to the pump discharge valves.

Normal operation upon pump shutdown now will require the pump discharge valve to be fully closed when the velocity has dropped to zero.

The surge relief valve will be fully open allowing backflow to enter the wet well at a reduced rate. As before, the relief valve must close slowly to avoid water hammer.



Use of Software for Water Hammer Analysis

Most cases involving large pump stations with long force mains, which contain several intermediate high points, will be too complex to solve by hand using conventional methods such as graphical solutions, arithmetic integration, or water hammer charts.

Many computer programs are now available for water hammer analysis, and are recommended for use in those instances.



Screening And Comminuting Devices





Screening And Comminuting Devices

Centrifugal pumps are susceptible to clogging by rags, trash, and other debris normally found in wastewater. To protect pumps from clogging, equipment will be installed to screen or cut up these materials prior to pumping.

Small pump stations with capacities of less than 200 gpm, including grinder pumps and pneumatic ejectors, are exempt from this requirement.



Bar Racks and Screens

The types of equipment to be used include bar racks, screens, and comminutors (see image) which are installed in the wet well, or in a separate influent channel.



Use of Manually-cleaned Racks at Smaller Stations

At most medium to large sized pump stations, the use of mechanically cleaned bar screens or comminutors will be required. However, at smaller stations in remote areas, manually cleaned racks may be more feasible.

The smallest clear opening between bars is normally 1 inch, and spacing of less than 3/4 inch will not be permitted. All electrically operated equipment in wet wells will have explosion proof motors.



Force Mains: Types of Piping



Factors for Selection of Pipe Materials, Fittings And Joints

Factors to be considered in the selection of pipe materials and piping systems for force mains are:

- Flow characteristics or friction coefficient
- Life expectancy and history of use
- Resistance to scour and abrasion
- Resistance to acids, alkalis,
- Resistance to high temperature, or corrosive wastes and soils
- Ease of handling and installation
- Physical strength and pressure rating
- Joint water-tightness and ease of installation
- Availability of pipe in required sizes, strengths, etc.
- Availability of fittings, connections and adapters



One Size doesn't Fit All

No pipe manufactured is suitable for all installation requirements and conditions. The pipe materials covered here, are the ones most often used for force mains carrying sanitary and industrial wastes.

Each type of pipe will be evaluated to determine its suitability for the particular design. Where iron or concrete pipe are to be considered, special attention should be paid to subsurface and soil conditions.





Soil Characteristics and Corrosion

The characteristics of the soil in which a pipe is placed affect the rate of corrosion, with the most corrosive soils being those having poor aeration and high values of acidity, electrical conductivity, dissolved salts, and moisture content.

The relative potential for corrosion may be estimated by evaluating the degree of corrosion of existing metallic or concrete pipelines previously buried in the soil.

When this information is not available, or is non-conclusive, resistivity tests of the soil should be conducted and results evaluated. Pipe materials found inappropriate for use should be removed from the project specifications.





Ductile Iron Pipe for Force Mains

Ductile iron (D.I.) pipe is suitable for force mains used at pumping stations and wastewater treatment facilities.

Special uses include river crossings, pipe located in unstable soil, highway and rail crossings, and piping installed above ground. D.I. pipe is susceptible to corrosion from acid wastes and aggressive soils.



Ductile Iron Pipe (continued)

Cement linings, bituminous coatings or polyethelene linings are usually provided for interior protections. For extremely corrosive soils, a polyethelene encasement is recommended for external protection.

Pipe is available in 3-inch through 54-inch diameters, and with mechanical, push-on or flanged joints. Flanged joints are restricted to interior piping.

The Handbook of Ductile Iron Pipe, Cast Iron Pipe published by the Cast Iron Pipe Research Association (CIPRA) will be used for guidance in designing ductile iron force mains.



Steel Pipe for Force Mains

Steel pipe may be used for force mains when lined with cement mortar or bituminous materials to provide internal protection. A bituminous coating must be applied for external protection also. Lined and coated steel pipe is available in diameters 6-inch through 144-inch.

Galvanized steel pipe will be used for small diameter force mains and pressure sewers from 1/4-inch to 4-inch in size. Joints for steel pipe less than 6-inch will be threaded. Pipe 6-inch in diameter and larger will have mechanical, push-on, or flanged joints. Threaded and flanged joints will be used only for interior piping.

Steel pipe will be installed in accordance with the manufacturer's recommendations, and Manual No. M11-Steel Pipe Design and Installation published by the American Water Works Association (AWWA).





Concrete Pressure Pipe for Force Mains

Concrete pressure pipe will generally be used where high strength or large diameter force mains are required.

Pre-tensioned reinforced concrete pressure pipe is available in diameters 10-inch through 42-inch, pre-stressed concrete pressure pipe in diameters 16-inch through 144-inch, and reinforced concrete pressure pipe in diameters 24-inch through 144-inch. Each type utilizes bell and spigot joints with rubber gaskets.

The Concrete Pressure Pipe Manual, Manual No. M9 published by the American Water Works Association (AWWA) will be used for design of force mains.



Asbestos-Cement Pipe for Force Mains

Force mains constructed of asbestos-cement (A.C.) pressure pipe are durable and light in weight. However, A.C. pipe is affected by corrosive wastes and aggressive soils, and must be provided with plastic linings for protection.

The type of material required for A.C. pipe will be type II in accordance with ASTM C 500. Pipe is available in diameters 4-inch through 42-inch, and will be joined by means of couplings utilizing rubber gaskets.

Design of A.C. force mains will conform to the manufacturer's recommendations.





Plastic Pipe for Force Mains

Characteristics which make plastic pipe highly desirable for force main use include high corrosion resistance, light weight, and low coefficient of friction.

Disadvantages - include the possibility of excessive pipe wall deflections when installed improperly or subjected to high temperature wastes, and chemical breakdown caused by prolonged exposure to sunlight.



Plastic Pipe (continued)

The following types of plastic pipe are suitable for use:

Polyvinyl chloride (PVC) - PVC pipe is available in diameters 4-inch through 12-inch, and with screw, push-on, or solvent weld joints.

Polyethylene (PE) - PE pipe may be used in diameters 1 1/2-inch through 48-inch. Pipe joints consist of mechanical, flanged, or heat fusion type.
(3) **Polypropylene (PP)**.

Pipe diameters available with polypropylene pipe are 1/2-inch through 4-inch.

All pipe will be joined by heat fusion methods. Screwed and flanged joint pipe will not be used underground.

Manufacturer's recommendations will be used in design of plastic pipe, in addition to the Handbook of PVC Pipe-Design and Construction published by the Uni-Bell Plastic Pipe Association.





Fiberglass Pipe for Force Mains

Fiberglass pipe provides a good alternative for use in large diameter force mains. High structural integrity, low pipe friction coefficient, and a high resistance to internal/external corrosion and to high temperature wastes, are important properties of fiberglass pipe.



Fiberglass Pipe (continued)

The following types of fiberglass pipe may be used:

Reinforced thermosetting resin pipe (RTRP) - may be installed in diameters of 6inch through 144-inch. Jointing systems for RTRP pipe include bell and spigot, flanged, or special mechanical type couplings. Elastomeric gaskets are used to provide flexible joints

Reinforced plastic mortar pipe (RPMP) - Pipe diameters available for RPMP pipe range from 8inch to 144-inch. Pipe joints are made with grooved couplings or bell and spigot joints utilizing rubber gaskets.

Design of fiberglass force mains will follow the manufacturer's recommendations.



Other Piping Specs

Pump suction and discharge piping inside the station - will normally be ductile iron or steel. However, other pipe materials covered in this chapter are not precluded from use.

Pipe, fittings and joints serving as force mains - will be selected to withstand the maximum internal operating pressures, including transient surges. The project specifications should indicate the appropriate pressure class and rating for each pipe application.



Force Mains: Valves And Appurtenances



Valves And Appurtenances

All valves will be installed in a manhole or valve structure with adequate drainage and protection against freezing.

The use of valves in wastewater pumping can be divided into the following categories:



Isolation Or Shutoff Valves

Where the need to isolate pumps or part of the piping system occurs, manually operated shutoff valves will be used.

Gate valves or butterfly valves generally serve as shutoff valves, however ball valves or plug valves may also be used.

Shutoff valves are required on the suction and discharge sides of all pumps.



Surge Control Valves

To protect pumps and piping from surges caused by pump shutdown or power failure, gravity operated swing check or ball check valves, or automatically operated cone, plug, ball or butterfly valves will be installed in the pump discharge line.



Blowoff Valves

A valve outlet installed at the low point in a force main, and arranged to drain or flush the pipeline, is termed a blowoff.

Normally, blowoffs will be required only on long depressed sections of force main, or where an accumulation of solids is likely to occur.

Blowoff connections will be installed in manholes or valve structures, and will be protected against freezing. A means of discharging to a suitable location materials flushed from the system will be provided.

The pipe size of the outlet connection should coincide with the size of the force main.



Air Valves

Air valves will be installed at high points in force mains for the purpose of admitting and releasing air. When the pipeline is taken out of service for draining, flushing and filling operations, a manually operated valve will be adequate.

However, where air pockets or pressures less than atmospheric are likely to occur with the pipeline in service and under pressure, automatic air release and/or air vacuum valves will be used.



Manual vs Automatic Valves

Manual valves - can also be used with the pipeline under pressure by leaving the valve partially open.

Automatic valves - are not recommended due to maintenance problems, and should be used only where absolutely required.

Automatic valves will be of a type specially designed for sewage, and will be provided with back-flushing connections.



Force Mains: Protection Measures



Thrust Protection using Restraints (Thrust Blocks)

Force mains will be restrained to resist thrusts that develop at bends, tees, wye connections and plugs in the pipe.

The magnitude of such forces can be calculated with the use of formulas found in standard hydraulics textbooks. Required methods of restraint will consist of tie rods and clamps, or concrete thrust blocks.

Restraints should be designed in accordance with Section VI of the CIPRA Handbook of Ductile Iron Pipe, Cast Iron Pipe.



Freeze Protection

Force mains will be installed with sufficient depth to prevent freezing, and to protect the pipe from structural damage.

A minimum cover depth of 3 feet will ordinarily be required for freeze protection. However, in unusually cold climates, a greater depth may be required.



Protection of Potable Water Lines

Force mains and pressure sewers will not be installed closer than 10 feet horizontally to potable water lines. If conditions prevent a 10-foot clearance, a minimum distance of 6 feet will be allowed provided the bottom of the water pipe is at least 12 inches above the top of the pressure pipe.

Where a pressure pipe must cross a potable water line, the pressure line will always be installed below the water line with a minimum vertical clearance of 2 feet.

Pressure pipe joints will not be closer than 3 feet to the crossing unless fully encased in concrete.



Pump Station: Construction Requirements



Station Configuration

The space requirements of pumps, piping and equipment, along with the storage volume required in the wet well, will be carefully determined so that the proper size, shape and configuration of the pumping station can be selected.

The size and shape of the station will often be dictated by equipment other than pumps, such as bar screens, comminutors, grit collectors, etc.

Rectangular or square structures normally have more usable interior space than circular ones, and will be employed whenever possible in the design of medium to large sized pumping facilities.

However, where the below ground portion of the station must be made deep to accommodate incoming sewers, and where foundation conditions are poor, circular caisson type structures will be required if lateral earth pressures are excessively high.



Package Type Stations

Factory assembled or package type stations will generally be circular in design, and will be anchored to base slabs where warranted by subsurface conditions. Pump stations located in cold regions or in seismic zones will require special design considerations.



Designing For Operation And Maintenance

The design of medium to large sized, conventional type pumping facilities will include adequate floor openings, doorways, or access hatches for the installation, removal, and replacement of the largest items of equipment.

Interior dimensions in the dry well will provide a minimum clearance of 4 feet between adjacent pump casings, and a minimum of 3 feet from each outboard pump to the closest wall.

Other major items of equipment will be provided similar spacing. A 7-foot minimum clearance between floor and overhead piping will be maintained where practicable.



Ingress and Egress

Smaller package type stations will be furnished with necessary access openings for removal of pumps and equipment, however interior dimensions and clearances will generally be less than for field erected stations.

Wet wells for medium to large sized stations will be divided into two or more compartments to facilitate cleaning and repairs.

Wet wells for all stations will have no length, width or diameter smaller than 4 feet. Eye bolts or trolley beams will be provided in smaller stations, and overhead bridge cranes in large stations, for hoisting and removing equipment from mountings.





Access (Vertical)

A suitable means of access will be provided, to service and maintain all equipment.

Stairs will be provided in medium to large sized stations so that personnel may inspect and maintain equipment.

Smaller stations, except those utilizing submersible pumps, will require the use of vertical safety ladders.



Drainage

A floor drainage system will be provided in the dry well, and throughout the superstructure, for collection of wash down, seepage, and stuffing box leakage.

These wastes will be piped or conveyed to the wet well, either by gravity or by sump pump. Openings to the wet well and dry well through the main floor of the station will be above the maximum flood level, or will otherwise be protected from flooding.



Materials Of Construction

Large to medium sized, conventional type stations will ordinarily be constructed of reinforced concrete. The above ground portion of the building may be of masonry, wood or metal panel construction.

Small package type stations will generally be manufactured of steel or fiberglass, with separate wet wells constructed of precast concrete or fiberglass manhole sections.



Cathodic/Corrosion Protection

Where steel structures are used, cathodic protection or appropriate corrosion control measures will be provided for the underground steel shell.

Alternatively, steel structures may be protected by a concrete or gunite coating where proof can be furnished by the manufacturer of satisfactory design life.

All structures will be designed to withstand flotation.



Personnel Safety

Guards will be placed on and around all equipment where operators may come in contact with moving parts.

Railings will be required around all floor openings, and along platforms or walkways, where there is a danger that personnel may fall. Warning signs will be placed at all hazardous locations.

Rubber mats will be provided in front of all electrical equipment where the potential exists for electrical shock.

Adequate lighting and ventilation will be provided as required.



Personnel Safety (continued)

In attended stations where the possibility exists for toxic, explosive, or otherwise hazardous atmospheres, proper design for personnel safety will be in conformance with the appropriate standards outlined by OSHA.

Design for fire protection will be in accordance with NFPA or other appropriate fire safety standards. Wastewater pumping stations will be classified as light hazard, industrial type occupancies.



Interior Climate Control

All pumping stations subject to possible freezing will be supplied with automatically controlled heaters in the equipment areas.

Unattended stations - temperatures will be maintained at 40 degrees F.

Attended stations - will be heated to 65 degrees F.

Although wet wells are generally unheated, thermostatically controlled heaters may be used to prevent condensation on walls and floors during cool weather, provided the ventilation system is shut off.



Ventilation

Wet wells - will be provided with a positive ventilation capacity of 30 air changes per hour during occupancy, based on the wet well volume below grade and above the minimum wastewater level.

Unattended dry wells - will be provided with a positive ventilation capacity of 30 air changes per hour.

Attended dry wells - will be provided with a continuously-operated ventilation capacity of 6 air changes per hour, supplemented with additional ventilation in warm climates to remove pump motor heat to within 5 degrees F. of the outside air temperature.

Supply intakes and exhaust outlets must be located properly to introduce fresh air and remove hazardous gases or fumes. The wet and dry well sides of the station will be provided with separate ventilation systems.



Electrical Equipment

Pump station equipment will be suitable for operation at either 208V, 230V, or 480V, 60 Hz, three phase power supplies.

However, equipment with motors smaller than 0.5 horsepower, including meters, switches, timers, clocks, and similar equipment, will be suitable for operation at a 125V, 60 Hz, single phase power source.



Electrical Equipment (continued)

Motor starters and controls - will be provided and housed in a factory assembled, free-standing control center located on the ground floor. The center will include motor starters, switches or circuit breakers, instrumentation and controls.

A pump station requiring a few small sized starters is an exception, and will employ wall mounted or stand mounted equipment. Enclosures for submersible pump controls will be installed above grade.

Local trouble alarms - will be provided at all pump stations. Alarms will be annunciated remotely from unattended stations. Alarm systems will be provided with manual silencing.



Standby Power

The requirement for fixed, standby power at wastewater pumping stations will depend upon the type, location, and critical nature of each pumping facility.

For stations situated in low lying areas, or in areas remote from a treatment plant, standby capability should be provided if a power outage would result in flooding of the station, overflows at sewer manholes, backup of wastes into buildings, or any unlawful pollution of the environment, or health hazard to personnel.



Standby Power (continued)

Pumping stations located at or in conjunction with treatment facilities, such as those required for influent pumping, recycling or bypassing of flows, and pumping of effluent, will require standby power capability if the pumping is essential to critical treatment processes, plant flow control, or is necessary to maintain compliance with the discharge permit.



Potable Water Supply

A potable water supply is required at all large pump stations to supply washroom and toilet facilities, hydrants, hose bibs and pump seal systems.

A wash basin and toilet facilities will be provided at pump stations which are attended regularly. Hose bibs will be provided in wet wells, dry wells and bar screen rooms.

The positive separation will be accomplished either by providing a break with an air gap, or by installing backflow prevention devices.



Potable Water Supply (continued)

Freeze proof wall hydrants will be required for outdoor use.

A positive separation will be maintained between the potable water system and any piping or appurtenances subject to contamination. Warning signs will be posted at all water taps not directly connected to the potable water supply.



Flow Measurement

Flow meters installed to indicate and record the discharge from the pump station, and from individual pumps, will be provided at all medium to large sized stations.

A meter installed in the discharge header provides valuable information on the operation of the station, and will be required where pumping capacity is expected to increase significantly in the future.

Pressure gages are required on individual pump discharge lines, and on the station discharge header. Elapsed time clocks will be mounted on all pump motor starters.



Flow Measurement (continued)

For smaller stations utilizing constant speed pumps, an elapsed time clock may be used in lieu of a pipe mounted flow meter to measure pump discharge. This will also aid in scheduling routine maintenance on the motor since most small stations are unattended.

A non-corrodible depth gage installed in the wet well will generally suffice for very small pumps; flows can be estimated from depth measurements taken manually.

The types of flow measuring devices to be used for large wastewater pumps of the constant, adjustable or variable speed type, include flow tubes, venturi meters, magnetic and ultrasonic flow meters.



Protective Coating Systems

The use of paints and protective coatings at wastewater pumping stations will be in accordance with Water Pollution Control Federation (WPCF) Manual of Practice No. 17.

A thorough investigation will be made in the design of protective coating systems. Paint materials selected will be appropriate for the types of surfaces being protected, both submerged and non-submerged.

Coating systems will be designed to resist corrosion from the wastes being handled, and from gases and vapors present, taking into consideration the expected temperature and humidity variations within the station.



Protective Coating Systems (continued)

Coating systems will consist of adequate surface preparation, and the application of prime and finish coats using compatible materials as recommended by the coatings manufacturer.

All pumps and equipment will receive protective coatings in conformance with the manufacturer's recommendations. All ferrous materials including galvanized surfaces will be protected.

Particular care should be taken to protect welds and threads at connections.

Package type stations should be shipped to the construction site with factory applied paints and coatings sufficient for the required service.



This concludes our course on “Fundamentals of Pump Station and Force Main Design”.
You may now proceed to the final exam.

Thank you for taking this Flashcard course!

