



Online Continuing Education for Professional Engineers  
Since 2009

# Coastal Construction: Load Path Considerations

PDH Credits:

**3 PDH**

Course No.:

**DTB101**

Publication Source:

**US FEMA**

**“Designing the Building”**

*Coastal Construction Manual*

*Chapter 9, Volume II*

*4th Edition*

Release Date:

2011

**DISCLAIMER:**

All course materials available on this website are not to be construed as a representation or warranty on the part of Online-PDH, or other persons and/or organizations named herein. All course literature is for reference purposes only, and should not be used as a substitute for competent, professional engineering council. Use or application of any information herein, should be done so at the discretion of a licensed professional engineer in that given field of expertise. Any person(s) making use of this information, herein, does so at their own risk and assumes any and all liabilities arising therefrom.



# 2 Designing the Building

This chapter provides guidance on design considerations for buildings in coastal environments. The topics discussed in this chapter are developing a load path through elements of the building structure, considerations for selecting building materials, requirements for breakaway walls, and considerations for designing appurtenances. Examples of problems for the development of the load path for specific building elements are provided, as well as guidance on requirements for breakaway walls, selection of building materials, and appurtenances.



## CROSS REFERENCE

For resources that augment the guidance and other information in this Manual, see the Residential Coastal Construction Web site (<http://www.fema.gov/rebuild/mat/fema55.shtm>).

## 9.1 Continuous Load Path

In hazard-resistant construction, the ability of the elements of a building, from the roof to the foundation, to carry or resist loads is critical. Loads include lateral and uplift loads. A critical aspect of hazard-resistant construction is the capability of a building or structure to carry and resist all loads—including lateral and uplift loads—from the roof, walls, and other elements to the foundation and into the ground. The term “continuous load path” refers to the structural condition required to resist loads acting on a building. A load path can be thought of as a chain running through the building. A building may contain hundreds of continuous load paths. The continuous load path starts at the point or surface where loads are applied, moves through the building, continues through the foundation, and terminates where the loads are transferred to the soils that support the building. Because all applied loads must be transferred to the foundation, the load path must connect to the foundation. To be effective, each link in the load path chain must be strong enough to transfer loads without breaking.

Buildings that lack strong and continuous load paths may fail when exposed to forces from coastal hazards, thus causing a breach in the building envelope or the collapse of the building. The ability of a building to resist these forces depends largely on whether the building's construction provides a continuous load path and materials that are appropriate for the harsh coastal environment. The history of storm damage is replete with instances of failures in load paths. Figures 9-1 through 9-5 show instances of load path failure.

**Figure 9-1.**  
Load path failure at gable end, Hurricane Andrew (Dade County, FL, 1992)



**Figure 9-2.**  
Load path failure in connection between home and its foundation, Hurricane Fran (North Carolina, 1996)







Figure 9-3.  
Roof framing damage and loss due to load path failure at top of wall/roof structure connection, Hurricane Charley (Punta Gorda, FL, 2004)



Figure 9-4.  
Load path failure in connections between roof decking and roof framing, Hurricane Charley (Punta Gorda, FL, 2004)

Most load path failures have been observed to occur at connections as opposed to the failure of an individual structural member (e.g. roof rafter or wall stud). Improvements in codes, design, and materials over the past decade have resulted in improved performance of structural systems. As the structural systems perform better, other issues related to load path—such as building envelope issues—become apparent.



#### CROSS REFERENCE

For a discussion of building envelope issues, see Chapter 11 of this Manual.

Figure 9-5.  
Newer home damaged  
from internal  
pressurization and  
inadequate connections,  
Hurricane Katrina (Pass  
Christian, MS, 2005)



Load path guidance in this chapter is focused primarily on elements of the building structure, excluding foundation elements. Foundation elements are addressed in Chapter 10. Examples are provided primarily to illustrate how the load path resists wind uplift forces, but a complete building design includes a consideration of numerous other forces on the load path, including those from gravity loads and lateral loads. The examples illustrate important concepts and best practices in accordance with building codes and standards but do not represent an exhaustive collection of load calculation methods. See the applicable building code, standard, or design manual for more detailed guidance.

Figure 9-6 shows a load path for wind uplift beginning with the connection of roof sheathing to roof framing and ending with the resistance of the pile to wind uplift. Links #1 through #8 in the figure show connections that have been observed during investigations after high-wind events to be vulnerable to localized failure. However, the load path does not end with the resistance of the pile to wind uplift. The end of transfer through the load path occurs when the loads from the building are transferred into the soil (see Chapter 10 for information about the interaction of foundations and soils). Adequately sizing and detailing every link is important for overall performance because even a small localized failure can lead to a progressive failure of the building structure. The links shown in Figure 9-6 are discussed in more detail in Sections 9.1.1 through 9.1.8. For additional illustration of the concept of load path, see Fact Sheet 4.1, *Load Paths*, in FEMA P-499 (FEMA 2010b).

### 9.1.1 Roof Sheathing to Framing Connection (Link #1)

Link #1 is the nailed connection of the roof sheathing to the roof framing (see Figures 9-6 and 9-7). Design considerations include ensuring the connection has adequate strength to resist both the withdrawal of the nail shank from the roof framing and the sheathing's pulling over the head of the fastener (also referred to as "head pull-through"). Because of the potential for head pull-through and the required minimum nailing for diaphragm shear capacity, fastener spacing is typically not increased even where shank withdrawal strength

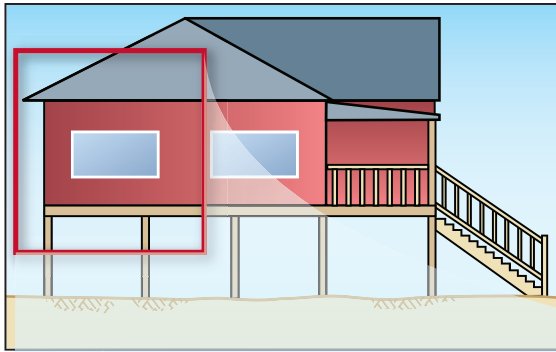

Figure 9-6.  
Example load path for case study building

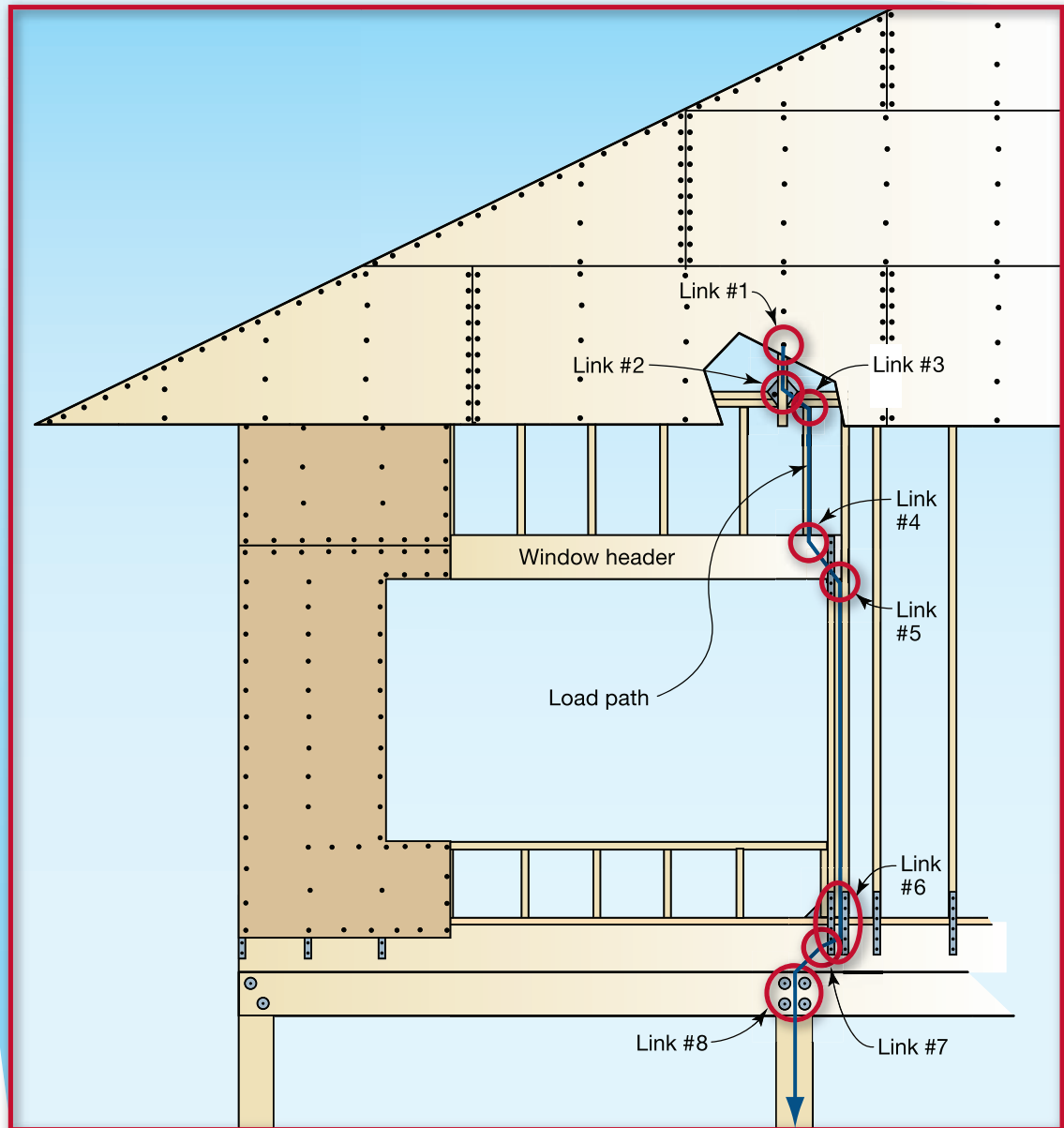
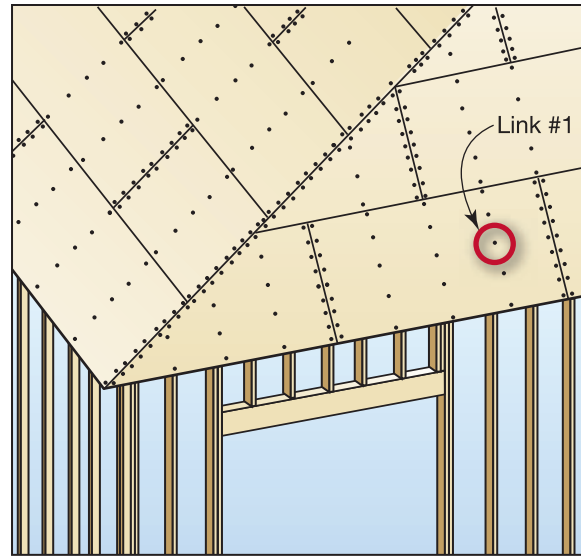

Figure 9-7.  
Connection of the roof sheathing to the roof framing (Link #1)



is significantly greater than that provided by a smooth shank nail. Additional strength can be added by using ring shank nails, also called deformed shank nails. The grooves and ridges along the shank act as wedges, giving the nail more withdrawal strength than a typical smooth shank nail.

Fastener attachment requirements for roof sheathing to roof framing are available in building codes and design standards and are presented in terms of nailing schedules dependent on nail diameter and length, framing spacing, specific gravity of framing lumber, and wind speed. Common assumptions for calculating nailing schedules to resist wind uplift are provided in Example 9.1. Minimum roof sheathing attachment prescribed in building codes and reference prescriptive standards is 6 inches o.c. at panel edges and 12 inches o.c. in the field of the panel.



### EXAMPLE 9.1. ROOF SHEATHING NAIL SPACING FOR WIND UPLIFT

**Given:**

- Refer to Figure 9-7
- Wind speed = 150 mph (700-year wind speed, 3-sec gust), Exposure Category D
- Roof sheathing = 7/16-in. oriented strand board (OSB)
- Roof framing specific gravity,  $G = 0.42$
- 8d common nail has withdrawal capacity of 66 lb/nail per the NDS

**Find:**

1. Nail spacing for the perimeter edge zone for rafter spacing of 16 in. o.c.
2. Nail spacing for the perimeter edge zone for rafter spacing of 24 in. o.c.



**EXAMPLE 9.1. ROOF SHEATHING NAIL SPACING FOR WIND UPLIFT** (continued)

**Solution for #1:** The following calculations are used to determine the nail spacing:

- From Table 8-8, the maximum wind suction pressure (based on ASD design) is:

$$p = 108.7 \text{ psf acting normal to the roof surface (Zone 3 overhang) for Exposure Category C}$$

The maximum wind suction pressure for Exposure D is:

$$p = 108.7 \text{ psf} (1.18) = 128.3 \text{ psf}$$

where:

1.18 = the adjustment factor from Exposure C to Exposure D at 33-ft mean roof height (see Example 8.10)

- The assumed minimum tributary area for calculation of this pressure is 10 ft<sup>2</sup> in accordance with Example 8.7
- For framing at 16 in. o.c., roof suction loads in plf are:

$$P = 128.3 \text{ psf} \frac{16 \text{ in.}}{12 \text{ in./ft}} = 171.0 \text{ plf}$$

- Nail spacing:

$$\text{Spacing} = \frac{66 \text{ lb/nail}}{171.0 \text{ plf}} = 0.386 \text{ ft} = 4.6 \text{ in.}$$

Rounding down to next typical spacing value, specify **4-in. spacing**

**Solution for #2:** The following calculations are used to determine the nail spacing:

- From Table 8-8, the maximum wind suction pressure is:

$$p = 108.7 \text{ psf acting normal to the roof surface (Zone 3 overhang) for Exposure Category C}$$

See Figure 8-18 and Table 8-8.

The maximum wind suction pressure for Exposure D is:

$$p = 108.7 \text{ psf} (1.18) = 128.3 \text{ psf}$$

where:

1.18 = adjustment factor from Exposure C to Exposure D at 33-ft mean roof height (see Example 8.10).

- The assumed minimum tributary area for calculation of this pressure is 10 ft<sup>2</sup> in accordance with Example 8.7.



**EXAMPLE 9.1. ROOF SHEATHING NAIL SPACING FOR WIND UPLIFT (concluded)**

- For framing at 24 in. o.c., roof suction loads on a plf basis is:

$$P = 128.3 \text{ psf} \frac{24 \text{ in.}}{12 \text{ in./ft}} = 256.5 \text{ plf}$$

- Nail spacing:

$$\text{Spacing} = \frac{66 \text{ lb/nail}}{256.5 \text{ plf}} = 0.26 \text{ ft} = 3.09 \text{ in.}$$

Rounding down to next typical spacing value, specify **3-in. spacing**

*Note:* Edge zone nail spacing associated with Zone 3 OH pressures is conservative for other edge zone locations. Although increased nail spacing may be calculated for an edge zone away from the building corners, it is recommended that the same nailing schedule be used throughout all edge zones.

**9.1.2 Roof Framing to Exterior Wall (Link #2)**

Link #2 is the connection between the roof framing member (truss or rafter) and the top of the wall below (see Figures 9-6 and 9-8) for resistance to wind uplift. Metal connectors are typically used where uplift forces are large. A variety of metal connectors are available for attaching roof framing to the wall. Manufacturers' literature should be consulted for proper use of the connector and allowable capacities for resistance to uplift. Prescriptive solutions for the connection of the roof framing to the wall top plates are available in building codes and wind design standards. One method of sizing the connection between the roof framing and the exterior wall is provided in Example 9.2.

**Figure 9-8.**  
Connection of roof framing to exterior wall (Link #2)

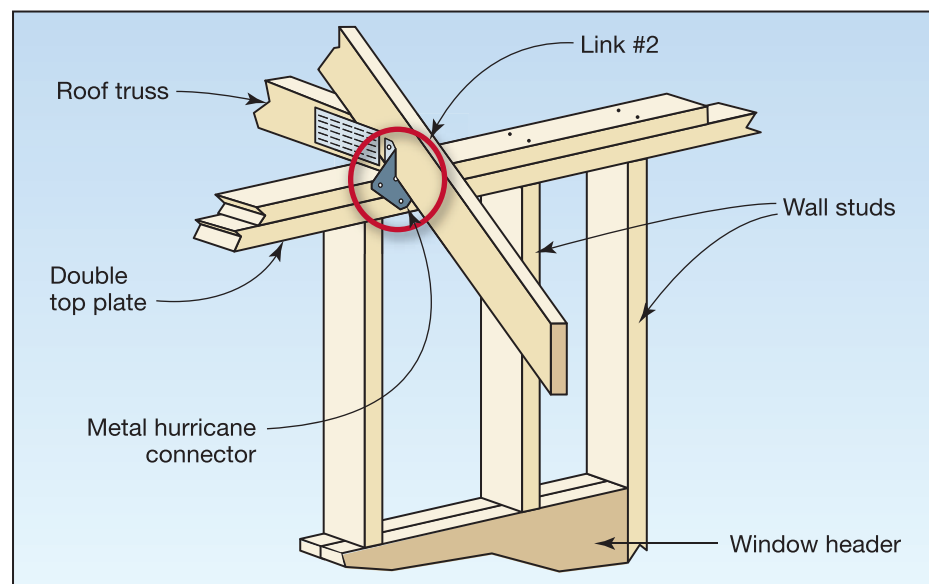



### EXAMPLE 9.2. ROOF-TO-WALL CONNECTION FOR UPLIFT

#### Given:

- Refer to Figure 9-8 and Illustration A
- Wind speed = 150 mph, Exposure D
- Mean roof height = 24 ft
- Rafter spacing = 24 in. o.c.
- Hip rafter span = 14 ft
- Roof pitch = 7:12
- Roof dead load = 10 psf
- Wall height = 10 ft

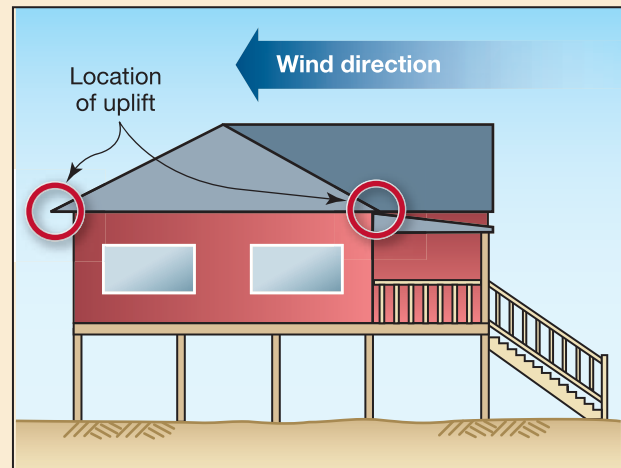

Illustration A. Location of uplift connection on hip roof

#### Find:

Determine the required connector size for wind uplift using prescriptive tables for wind uplift loads (i.e., find the uplift and lateral loads for the connector).

**Solution:** The required connector size using wind uplift prescriptive tables can be determined as follows:

#### *Uplift*

- For this example, the maximum hip rafter span = 14 ft
- To use Table 8-6, the uplift strap connector load should be obtained for a 28-ft roof width (e.g., 28 ft is 2 times the 14-ft maximum hip rafter span; see the note at the end of this Example)
- Interpolating between the 24-ft and 32-ft roof span uplift strap connector loads for 150 mph wind speed in Exposure C is:

$$\frac{(424 \text{ plf} + 534 \text{ plf})}{2} = 479 \text{ plf}$$

Adjust to Exposure Category D by multiplying by 1.18 (see Example 8.10)

$$1.18(479 \text{ plf}) = 565.2 \text{ plf}$$

- For rafter framing at 2 ft on center, the uplift connector force is:

$$(565.2 \text{ plf})(2 \text{ ft}) = \mathbf{1,131 \text{ lb}}$$

#### *Lateral*

- The lateral load on the connector is = 205 plf (see Table 8-9) for Exposure Category C
- Adjusting for Exposure Category D

**EXAMPLE 9.2. ROOF-TO-WALL CONNECTION FOR UPLIFT (concluded)**

- $1.18(205 \text{ plf}) = 241.9 \text{ plf}$  for rafter framing at 2 ft o.c., the lateral connector force at each rafter is:

$$(241.9 \text{ plf})(2 \text{ ft}) = \mathbf{484 \text{ lb}}$$

**Note:** Although the connector forces shown in Table 8-9 assume a gable roof, requirements can be conservatively applied for attaching the hip rafter to the wall. See Table 2.5A, *Wood Frame Construction Manual for One- and Two-Family Dwellings (AF&PA 2012)*. Note that the example roof uses both a gable roof and hip roof framing. For simplicity, the same rafter connection is often used at each connection between the rafter and wall framing. In addition, although smaller forces are developed in shorter hip roof rafter members, the same connector is typically used at all hip rafters.

Figure 9-9 shows truss-to-wood wall connections made with metal connectors. Figure 9-10 shows a rafter-to-masonry wall connector that is embedded into the concrete-filled or grouted masonry cell.

**Figure 9-9.**  
Connection of truss to  
wood-frame wall



### 9.1.3 Wall Top Plate to Wall Studs (Link #3)

Link #3 is the connection between the wall top plates and the wall stud over the window header (see Figures 9-6 and 9-11). The connection provides resistance to the same uplift force as used for the roof framing to the exterior connection minus the weight of the top plates. An option for maintaining the uplift load path is the use of metal connectors between the top plates and wall studs or wood structural panel sheathing (see Figure 9-12). The uplift load path can be made with wood structural panel wall sheathing, particularly when the uplift and shear forces in the wall are not very high. Guidance on using wood structural panel wall sheathing for resisting wind uplift is provided in ANSI/AF&PA SDPWS-08. The lateral load path (e.g., out-of-plane wall loads) is maintained by stud-to-top plate nailing.

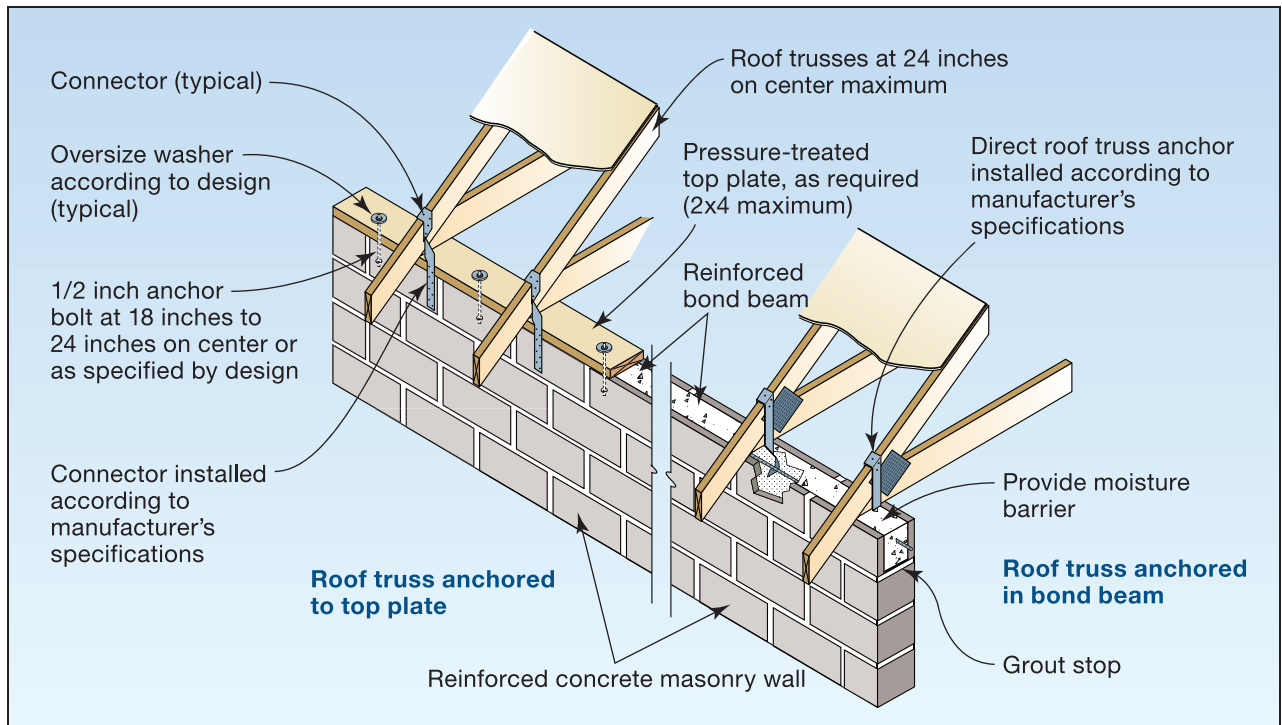

**Figure 9-10.** Roof truss-to-masonry wall connectors embedded into concrete-filled or grouted masonry cell (left-hand side image has a top plate installed while the right-hand side does not)

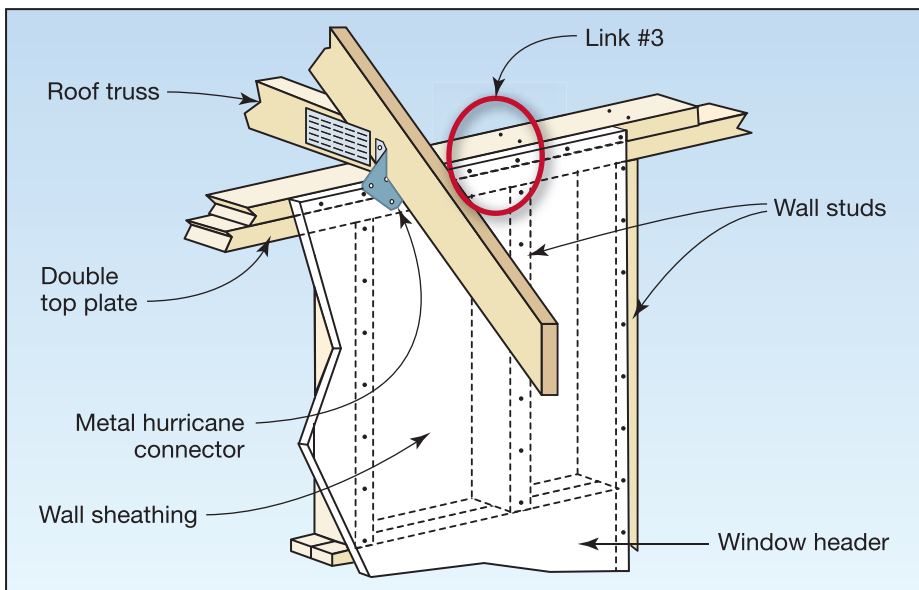
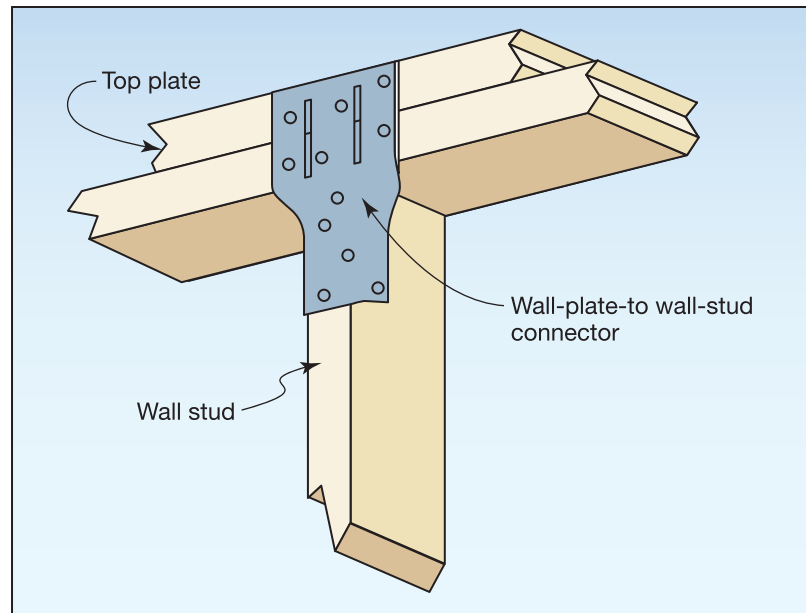

**Figure 9-11.** Connection of wall top plate-to-wall stud (Link #3)

For masonry or concrete walls, the wood sill plate is typically connected by anchor bolts, cast-in straps, or other approved fasteners capable of maintaining a load path for uplift, lateral, and shear loads. Anchorage spacing varies based on the anchorage resistance to pullout, the resistance of the plate to bending, and strength of the anchorage in shear. Anchorage must be spaced to resist pullout, and the plate must resist bending and splitting. Placing anchor bolts close together assists in reducing the bending stress in the plate.



Figure 9-12.  
Wall top plate-to-wall  
stud metal connector



#### 9.1.4 Wall Sheathing to Window Header (Link #4)

Link #4 is the connection between the wood structural panel wall sheathing and the window header (see Figures 9-6 and 9-13). The connection maintains the uplift load path from the wall top plates for the same force as determined for the roof connection to the wall minus additional dead load from the wall. Options for maintaining the uplift load path include using metal connectors between the wall studs and header or wood structural panel sheathing (see Figures 9-13 and 9-14). The uplift load path is frequently made with wood structural panel wall sheathing, particularly when the uplift and shear forces in the wall are not very high. Additional design considerations include the resistance of the window header to bending from gravity loads, wind uplift, and out-of-plane bending loads from wind.

In masonry construction, a masonry or concrete bond beam, or a pre-cast concrete or masonry header, is often used over the window opening. Design considerations for this beam include resistance to bending in both the plane of the wall and normal to the wall. Resistance to bending is accomplished by placing reinforcing steel in the bond beam. Reinforcing steel must be placed in the bond beam in order for the beam to adequately resist bending stresses. The design of these members is beyond the scope of this Manual; therefore, the prescriptive methods presented in ICC 600-2008, or concrete and masonry references should be used.

#### 9.1.5 Window Header to Exterior Wall (Link #5)

Link #5 is the connection from the window header to the adjacent wall framing (see Figures 9-6 and 9-14). Link #5 provides resistance to wind uplift and often consists of a metal strap or end-nailing the stud to the header. The total uplift force is based on the uplift forces tributary to the header. Maintaining the load path for the out-of-plane forces at this location includes consideration of both the positive (inward) and the negative (outward) pressures from wind. This load path is commonly developed by the stud-to-header nailing. One method of sizing the connection between the window header and the exterior wall is provided in Example 9.3.

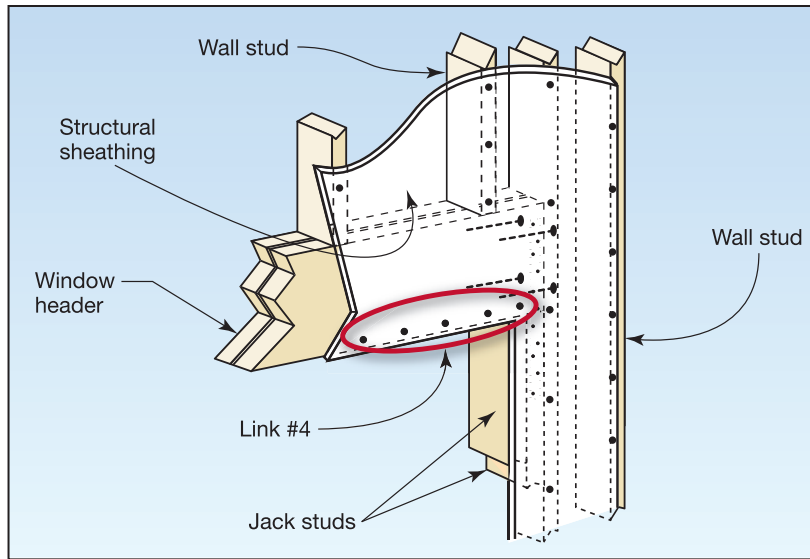

Figure 9-13.  
Connection of wall sheathing to window header (Link #4)

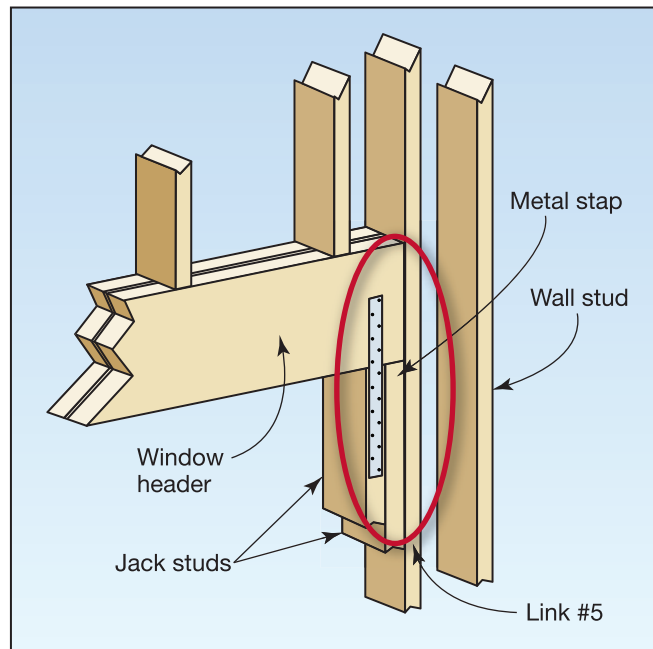

Figure 9-14.  
Connection of window header to exterior wall (Link #5)



### EXAMPLE 9.3. UPLIFT AND LATERAL LOAD PATH AT WINDOW HEADER

#### Given:

- Refer to Figure 9-14 and Illustration A
- Unit uplift load on window header = 565.2 plf (from Example 9.2)
- Unit lateral load on header = 241.9 plf (from Example 9.2)
- Header span = 14 ft

#### Find:

- Uplift and lateral load for connection of the header to the wall framing.

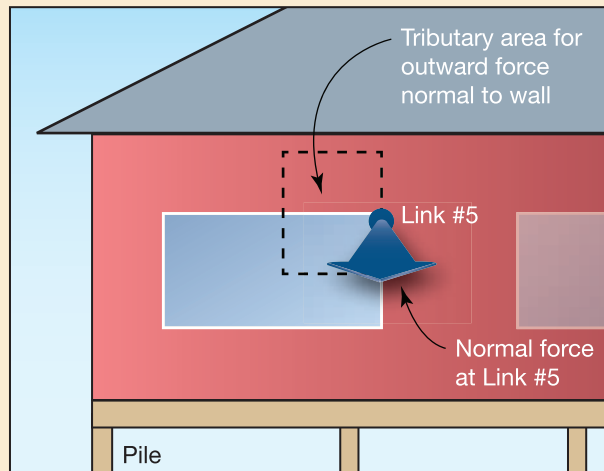

Illustration A. Tributary area for wind force normal to wall (Link #5)

**Solution:** The uplift and lateral forces can be determined as follows:

#### *Uplift*

- Ignore the contribution of the wall's dead load for resistance to uplift because the amount of wall dead load above the header connection is small

$$\text{Uplift load} = \frac{(565.2 \text{ plf})(\text{header span})}{2} = (479 \text{ plf})(7 \text{ ft}) = \mathbf{3,955 \text{ lb}}$$

$$\text{Lateral load} = \frac{(241.9 \text{ plf})(\text{header span})}{2} = (241.9 \text{ plf})(7 \text{ ft}) = \mathbf{1,694 \text{ lb}}$$

### 9.1.6 Wall to Floor Framing (Link #6)

Link #6 is the connection of the wall framing to the floor framing (see Figures 9-6 and 9-15) for resistance to wind uplift. This connection often includes use of metal connectors between the wall studs and the band joist or wood structural panel sheathing. In addition to uplift, connections between wall and floor framing can be used to maintain the load path for out-of-plane wall forces from positive and negative wind pressures and forces in the plane of the wall from shear. One method of sizing the wind uplift and lateral connections between the wall framing and the floor framing is provided in Example 9.4.

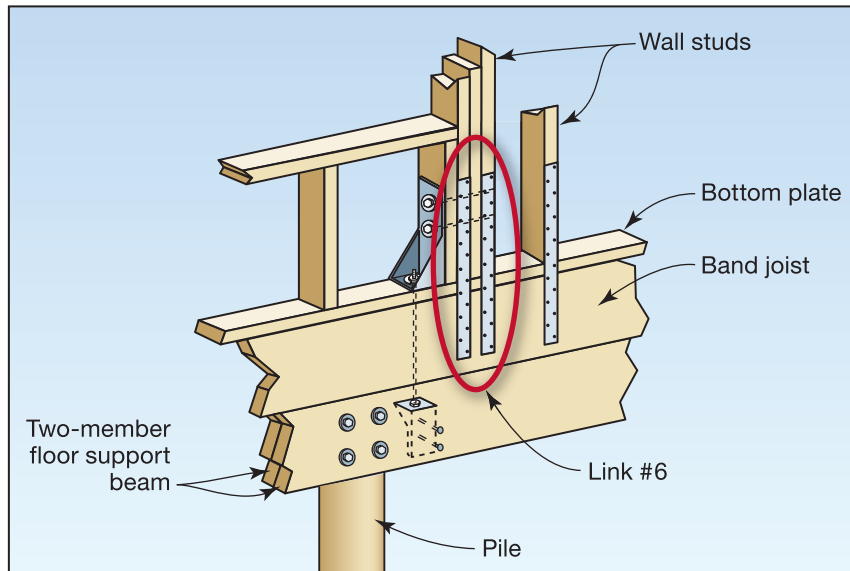

Figure 9-15.  
Connection of wall to  
floor framing (Link #6)



#### EXAMPLE 9.4. UPLIFT AND LATERAL LOAD PATH AT WALL-TO-FLOOR FRAMING

##### Given:

- Refer to Figure 9-15
- Unit uplift load at top of wall 565.2 plf (from Example 9.2)
- Unit lateral load = 241.9 plf (from Example 9.2)
- Wall dead load = 10 psf
- Wall height = 10 ft
- Wood specific gravity,  $G = 0.42$
- Three 16d common stud-to-plate nails per stud to provide resistance to lateral loads
- Two 16d common plate-to-band joist nails per ft to provide resistance to lateral loads



### EXAMPLE 9.4. UPLIFT AND LATERAL LOAD PATH AT WALL-TO-FLOOR FRAMING (concluded)

**Find:**

- Uplift load for wall-to-floor framing connections and if framing connections are adequate to resist the lateral loads.

**Solution:** Determine the uplift and lateral load for the wall-to-floor framing connections as follows:

*Uplift:*

$$\text{Wall dead load} = (10 \text{ psf})(10\text{-ft wall height}) = 100 \text{ plf}$$

$$\text{Uplift load at top of wall} = 565.2 \text{ plf}$$

$$\text{Uplift load at the base of the wall} = 565.2 \text{ plf} - 0.6(100 \text{ plf}) = 505.2 \text{ plf}$$

where:

$$0.6 = \text{load factor on dead load used to resist uplift forces}$$

For connectors spaced at 16 in. o.c., the minimum uplift load per connector is:

$$\text{Uplift load per connector} = (505.2 \text{ plf}) \frac{16 \text{ in.}}{12 \text{ in./ft}} = \mathbf{674 \text{ lb}}$$

*Lateral:*

- Stud-to-plate nail resistance to lateral loads can be calculated as:

$$\text{Lateral resistance} = (3 \text{ nails/ft})(120 \text{ lb/nail})(1.6)(0.67) = 386 \text{ lb}$$

where:

$$1.6 = \text{NDS load duration factor}$$

$$0.67 = \text{NDS end grain factor}$$

Because studs are at 16 inches o.c., unit lateral load resistance is:

$$\text{Lateral resistance} = (386 \text{ lb}) \frac{12 \text{ in./ft}}{16 \text{ in.}} = \mathbf{289 \text{ lb}}$$

$$289 \text{ plf} > 241.9 \text{ plf} \checkmark$$

- Plate-to-band joist nail resistance to lateral can be calculated as:

$$\text{Lateral resistance} = (2 \text{ nails/ft})(120 \text{ lb/nail})(1.6) = 384 \text{ plf}$$

where:

$$1.6 = \text{NDS load duration factor}$$

$$384 \text{ plf} > 241.9 \text{ plf} \checkmark$$

**The wall-to-floor framing connections provide adequate resistance to lateral forces.**

### 9.1.7 Floor Framing to Support Beam (Link #7)

Link #7 is the connection between the floor framing and the floor support beam (see Figures 9-6, 9-16, 9-17, and 9-18). The connection transfers the uplift forces that are calculated in Example 9.4. Options for maintaining the uplift load path for wind uplift include using metal connectors (see Figures 9-16 and 9-17) between the floor joist and the band joist or wood blocking (see Figure 9-18). Connections are also necessary to maintain a load path for lateral and shear forces from the floor and wall framing into the support beam. One method of sizing the wind uplift connections between the floor framing and support beam is provided in Example 9.5.

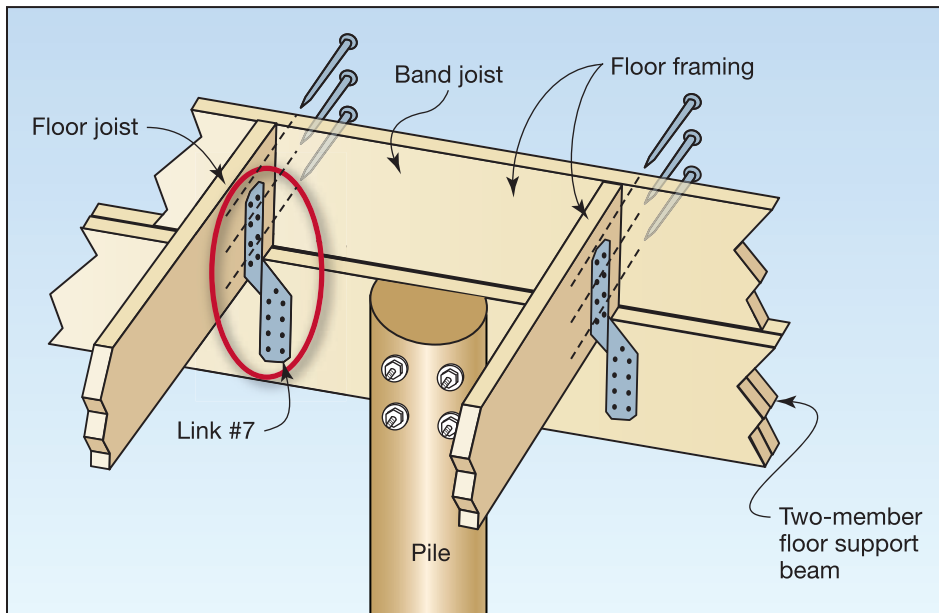

**Figure 9-16.** Connection of floor framing to support beam (Link #7) (band joist nailing to the floor joist is adequate to resist uplift forces)



**Figure 9-17.** Metal joist-to-beam connector



### EXAMPLE 9.5. UPLIFT LOAD PATH AT FLOOR TO SUPPORT BEAM FRAMING

**Given:**

- Refer to Figure 9-16
- Unit uplift load at top of wall 565.2 plf (from Example 9.2)
- Wall dead load = 10 psf
- Floor dead load = 10 psf
- Wall height = 10 ft

**Find:**

- Uplift load for floor framing to beam connections

**Solution:** The uplift load for the floor framing to beam connections can be determined as follows:

*Uplift:*

$$\text{Wall dead load} = (10 \text{ psf})(10 \text{ ft wall height}) = 100 \text{ plf}$$

$$\text{Floor dead load} = 10 \text{ psf} \frac{14 \text{ ft}}{2} = 70 \text{ plf}$$

$$\text{Uplift load at the base of the floor} = 565.2 \text{ plf} - 0.6 (100 \text{ plf} + 70 \text{ plf}) = 463.2 \text{ plf}$$

where:

$$0.6 = \text{load factor on dead load used to resist uplift forces}$$

For connectors spaced at 16 in. o.c., the minimum uplift load per connector is:

$$\text{Uplift load per connector} = (463.2 \text{ plf}) \frac{16 \text{ in.}}{12 \text{ in./ft}} = \mathbf{618 \text{ lb}}$$

### 9.1.8 Floor Support Beam to Foundation (Pile) (Link #8)

Link #8 is the connection of the floor support beam to the top of the pile (see Figures 9-6 and 9-18). Link #8 resists wind uplift forces, and the connection often consist of bolts in the beam-to-pile connection or holddown connectors attached from wall studs above to the pile. One method of sizing the wind uplift connections between the floor support beam and piles is provided in Example 9.6.

The connection of the beam to the pile is also designed to maintain load path for lateral and shear forces. It is typically assumed that lateral and shear forces are transferred through the floor diaphragm and can therefore be distributed to other support beam-to-pile connections. Stiffening of the diaphragm can be achieved by installing braces at each corner pile between the floor support beam in the plane of the floor (see Figure 9-19) or sheathing the underside of the floor framing. Stiffening also reduces pile cap rotation. The load path, however, does not end at Link #8. The load path ends with the transfer of loads from the foundation into

the soil. See Chapter 10 for considerations that must be taken into account with regard to the interaction between the foundation members and soil in the load path.

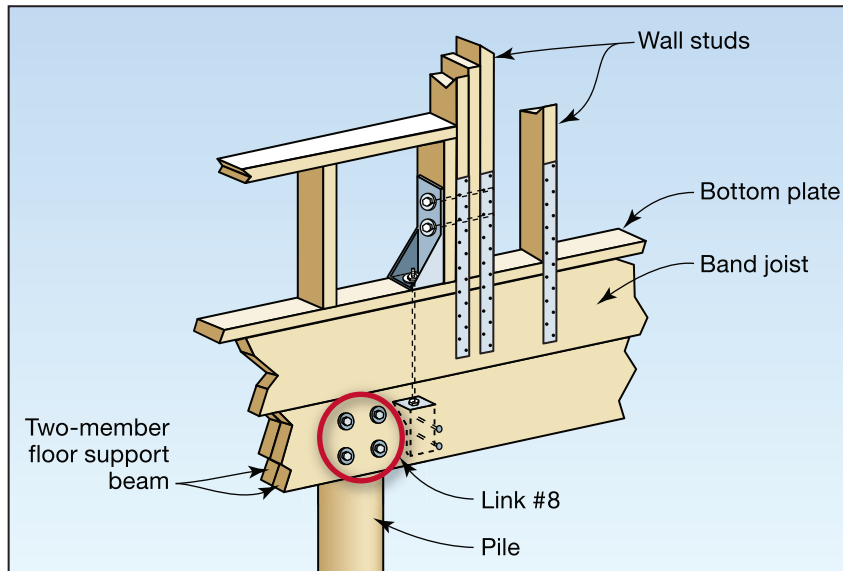

Figure 9-18.  
Connection of floor  
support beam to  
foundation (Link #8)



### EXAMPLE 9.6. UPLIFT LOAD PATH FOR SUPPORT BEAM TO PILE

#### Given:

- Refer to Figure 9-18
- Unit uplift load at top of floor beams = 463.2 plf (from Example 9.5)
- Pile spacing = 9.33 ft
- Continuous beam of 28-ft length at end wall
- ASD capacity for 1-in. diameter bolt in beam-to-pile connection = 1,792 lb (where wood specific gravity ( $G$ ) = 0.42, 3.5-in. side member, and 5.25-in. main member)

#### Find:

1. Uplift load for support beam-to-pile connections.
2. Number of bolts required for support beam-to-pile connections for wind uplift.

**Solution for #1:** The uplift load for the support beam-to-pile connections can be determined as follows:

*Uplift:*

Tributary length of center pile connection = 9.33 ft



**EXAMPLE 9.6. UPLIFT LOAD PATH FOR SUPPORT BEAM-TO-PILE (concluded)**

Uplift load at center pile connection =  $(9.33 \text{ ft})(463.2 \text{ plf}) = 4,322 \text{ lb}$

Tributary length of end pile connection =  $\frac{9.33 \text{ ft}}{2} = 4.67 \text{ ft}$

Uplift load at end pile connection =  $(4.67 \text{ ft})(463.2 \text{ plf}) = 2,163 \text{ lb}$

**Solution for #2:** The number of bolts required for the support beam-to-pile connections can be determined as follows:

Connection at center pile (number of bolts) =

Connection at center pile (number of bolts) =  $\frac{4,322 \text{ lb}}{1,792 \text{ lb/bolt}} = 2.41 \text{ bolts} =$

**3 bolts at support beam-to-pile connection**

Connection at end pile (number of bolts) =  $\frac{2,163 \text{ lb}}{1,792 \text{ lb/bolt}} = 1.21 \text{ bolts} =$

**2 bolt at support beam-to-pile connection**

**Figure 9-19.**  
Diaphragm stiffening and  
corner pile bracing to  
reduce pile cap rotation

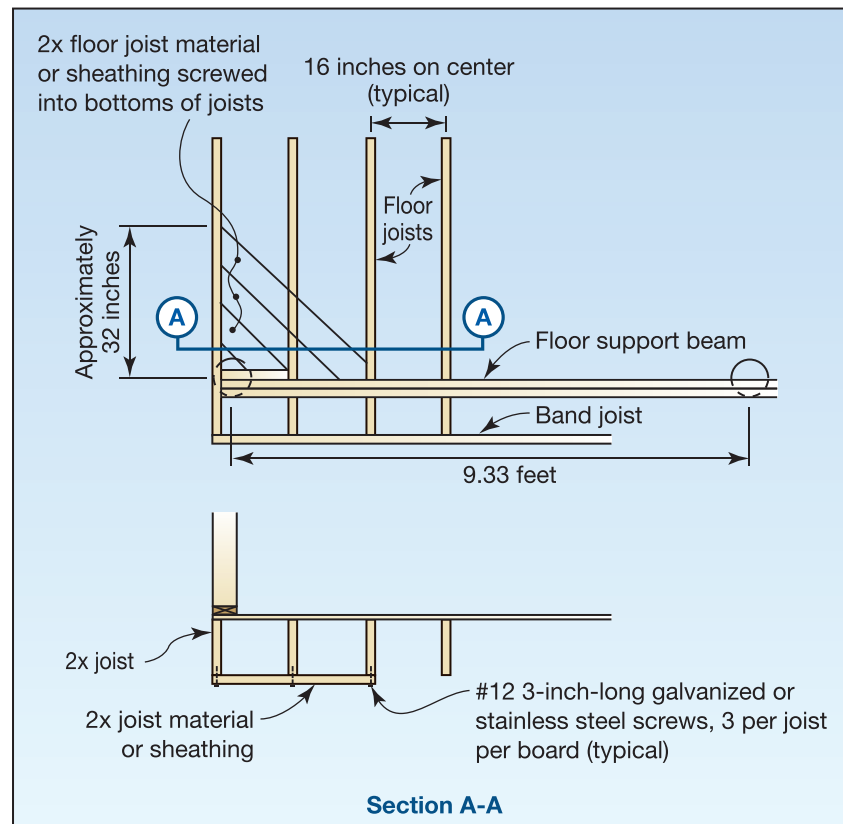

## 9.2 Other Load Path Considerations

Several additional design considerations must be investigated in order for a design to be complete. The details of these investigations are left to the designer, but they are mentioned here to more thoroughly cover the subject of continuous load paths and to point out that many possible paths require investigation.

Using the example of the building shown in Example 9.3, Illustration A, the following load paths should also be investigated:

- Load paths for shear transfer between shear walls and diaphragms including uplift due to shear wall overturning
- Gable wall support for lateral wind loads
- Uplift of the front porch roof
- Uplift of the main roof section that spans the width of the building

Other factors that influence the building design and its performance are:

- Connection choices
- Building eccentricities
- Framing system
- Roof shape

### 9.2.1 Uplift Due to Shear Wall Overturning

The shear wall that contains Link #6 includes connections designed to resist overturning forces from wind acting perpendicular to the ridge (see Example 9.7, Illustration A). Calculation of the overturning induced uplift and compressive forces are given in Example 9.7.



#### EXAMPLE 9.7. UPLIFT AND COMPRESSION DUE TO SHEAR WALL OVERTURNING

**Given:**

- Refer to Illustration A
- Wind speed = 150 mph, Exposure D
- Mean roof height = 33 ft
- Roof span perpendicular to ridge = 28 ft
- Roof pitch = 7:12
- Wall height = 10 ft

**EXAMPLE 9.7. UPLIFT AND COMPRESSION DUE TO SHEAR WALL OVERTURNING**  
(continued)

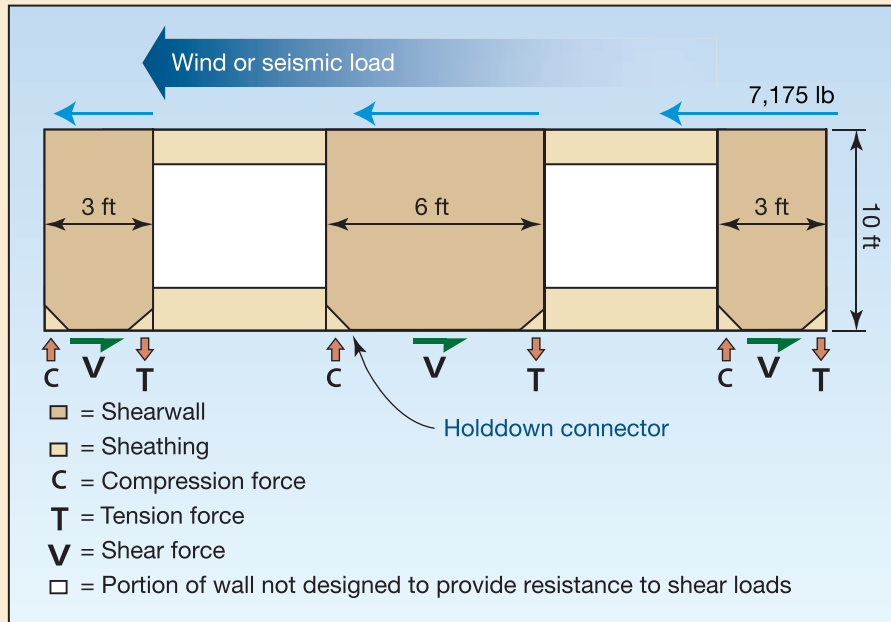

**Illustration A. Loads on south shear wall**

**Find:** Uplift and compressive force due to shear wall overturning.

**Solution:** The uplift and compressive force due to shear wall overturning can be determined as follows:

- The total shear force due to wind acting perpendicular to the ridge is determined for the 28-ft roof span by interpolation from Table 8-7:

$$\text{Roof diaphragm load for 24-ft roof span} = 256 \text{ plf}$$

$$\text{Roof diaphragm load for 32-ft roof span} = 299 \text{ plf}$$

$$\text{Roof diaphragm load for 28-ft roof span} = \frac{(256 \text{ plf} + 299 \text{ plf})}{2} = 278 \text{ plf}$$

Adjusting the roof diaphragm load to account for the building being located in Exposure Category D:

$$1.18(278 \text{ plf}) = 328 \text{ plf}$$

To adjust  $w_{roof}$  for a wall height of 10 ft because Table 8.7 assumes a wall height of 8 ft

$$328 \text{ plf} \left( \frac{10 \text{ ft}}{8 \text{ ft}} \right) = 410 \text{ plf}$$

### EXAMPLE 9.7. UPLIFT AND COMPRESSION DUE TO SHEAR WALL OVERTURNING (concluded)

- The total shear load for south wall assuming flexible diaphragm distribution of roof diaphragm load is calculated as follows:

$$\text{Length tributary to shear walls} = \frac{35 \text{ ft}}{2} = 17.5 \text{ ft (see Example 9.3, Illustration A)}$$

$$\text{Shear load in south shear walls} = (17.5 \text{ ft})(410 \text{ plf}) = 7,175 \text{ lb}$$

Shear wall segment aspect ratio (see Illustration B):

- Each shear wall segment must meet the requirements for shear wall aspect ratio in order to be considered as a shear resisting element. For wood structural panel shear walls, the maximum ratio of height to length (e.g., aspect ratio, h/L) is 3.5:1.
- The aspect ratio for shear wall segments in Illustration A can be calculated as follows:

$$\text{Aspect ratio of 6-ft long shear wall segment: } \frac{10 \text{ ft}}{6 \text{ ft}} = 1.67 < 3.5 \checkmark$$

$$\text{Aspect ratio of 3-ft long shear wall segment: } \frac{10 \text{ ft}}{3 \text{ ft}} = 3.33 < 3.5 \checkmark$$

$$\text{Unit shear, } v = \text{total shear load/shear wall length} = \frac{7,175 \text{ lb}}{(6 \text{ ft} + 3 \text{ ft} + 3 \text{ ft})} = 598 \text{ plf}$$

$$\begin{aligned} \text{Uplift (} T \text{) and compressive force (} C \text{) at shear wall ends due to overturning} \\ = (598 \text{ plf})(10\text{-ft wall height}) = \mathbf{5,980 \text{ lb}} \end{aligned}$$

***Note:** As seen in this example, tension and compression forces due to shear wall overturning can be large. Alignment of shear wall end posts with piles below facilitates use of standard connectors and manufacturers' allowable design values. A check of the pile uplift and compressive capacity in soil is needed to ensure an adequate load path for overturning forces.*

Because of the magnitude of overturning induced uplift and compression forces, it is desirable to align shear wall ends with piles to provide direct vertical support and to minimize offset of the tension or compression load path from the axis of the pile. Where shear wall end posts are aligned with piles below, detailing that allows connection of the shear wall end post holddown directly to the pile is desirable to minimize forces transferred through other members such as the support beams. Where direct transfer of overturning induced uplift and compression forces into the pile is not possible, minimizing the offset distance reduces bending stresses in the primary support beam (see Figure 9-20). For the holddown connection shown in Figure 9-20, the manufacturers' listed allowable load will be reduced because the bolted connection to the wood beam is loaded perpendicular to grain rather than parallel to grain.

Figure 9-20.  
Shear wall holddown  
connector with bracket  
attached to a wood beam



### 9.2.2 Gable Wall Support

There are many cases of failures of gable-end frames during high-wind events. The primary failure modes in gable-end frames are as follows:

- A gable wall that is not braced into the structure collapses, and the roof framing falls over (see Figure 9-21)
- An unsupported rake outrigger used for overhangs is lifted off by the wind and takes the roof sheathing with it
- The bottom chord of the truss is pulled outward, twisting the truss and causing an inward collapse

The need for and type of bracing at gable-end frames depend on the method used to construct the gable end. Recommendations for installing rafter outriggers at overhangs for resistance to wind loads are provided in the *Wood Frame Construction Manual* (American Wood Council, 2001). In addition to using the gable-end truss bracing shown in Figure 9-22, installing permanent lateral bracing on all roof truss systems is recommended. Gable-end trusses and conventionally framed gable-end walls should be designed, constructed, and sheathed as individual components to withstand the pressures associated with the established basic wind speed.

### 9.2.3 Connection Choices

Alternatives for joining building elements include:

- Mechanical connectors such as those available from a variety of manufacturers
- Fasteners such as nails, screws, bolts, and reinforcing steel



#### CROSS REFERENCE

For recommendations on corrosion-resistant connectors, see Table 1 in NFIP Technical Bulletin 8, *Corrosion Protection for Metal Connectors in Coastal Areas* (FEMA 1996).





Figure 9-21.  
Gable-end failure,  
Hurricane Andrew (Dade  
County, FL, 1992)

- Connectors such as wood blocks
- Alternative materials such as adhesives and strapping

Most commercially available mechanical connectors recognized in product evaluation reports are fabricated metal devices formed into shapes designed to fit snugly around elements such as studs, rafters, and wall plates. To provide their rated load, these devices must be attached as specified by the manufacturer. Mechanical connectors are typically provided with various levels of corrosion resistance such as levels of hot-dip galvanizing and stainless steel. Hot-dip galvanizing may be applied before or after fabrication. Thicker galvanized coatings can consist of 1 to 2 ounces of zinc per square foot. Thicker coatings provide greater protection against corrosion. Welded steel products generally have a hot-dip galvanized zinc coating or are painted for corrosion protection. Stainless steel (A304 and A316) connectors also provide corrosion resistance. Because exposed metal fasteners (even when galvanized) can corrode in coastal areas within a few years of installation, stainless steel is recommended where rapid corrosion is expected. According to FEMA NFIP Technical Bulletin 8-96, the amount of salt spray in the air is greatest near breaking waves and declines with increasing distance away from the shoreline. The decline may be rapid in the first 300 to 3,000 feet. FEMA P-499 recommends using stainless steel within 3,000 feet of the coast (including sounds and back bays).

Metal connectors must be used in accordance with the manufacturer's installation instructions in order for the product to provide the desired strength rating and to ensure that the product is suitable for a particular application. Particular attention should be given to the following information in the installation instructions:

- Preservative treatments used for wood framing
- Level of corrosion protection
- Wood species or lumber type used in framing (e.g., sawn lumber, pre-fabricated wood I-joists, laminated veneer lumber)

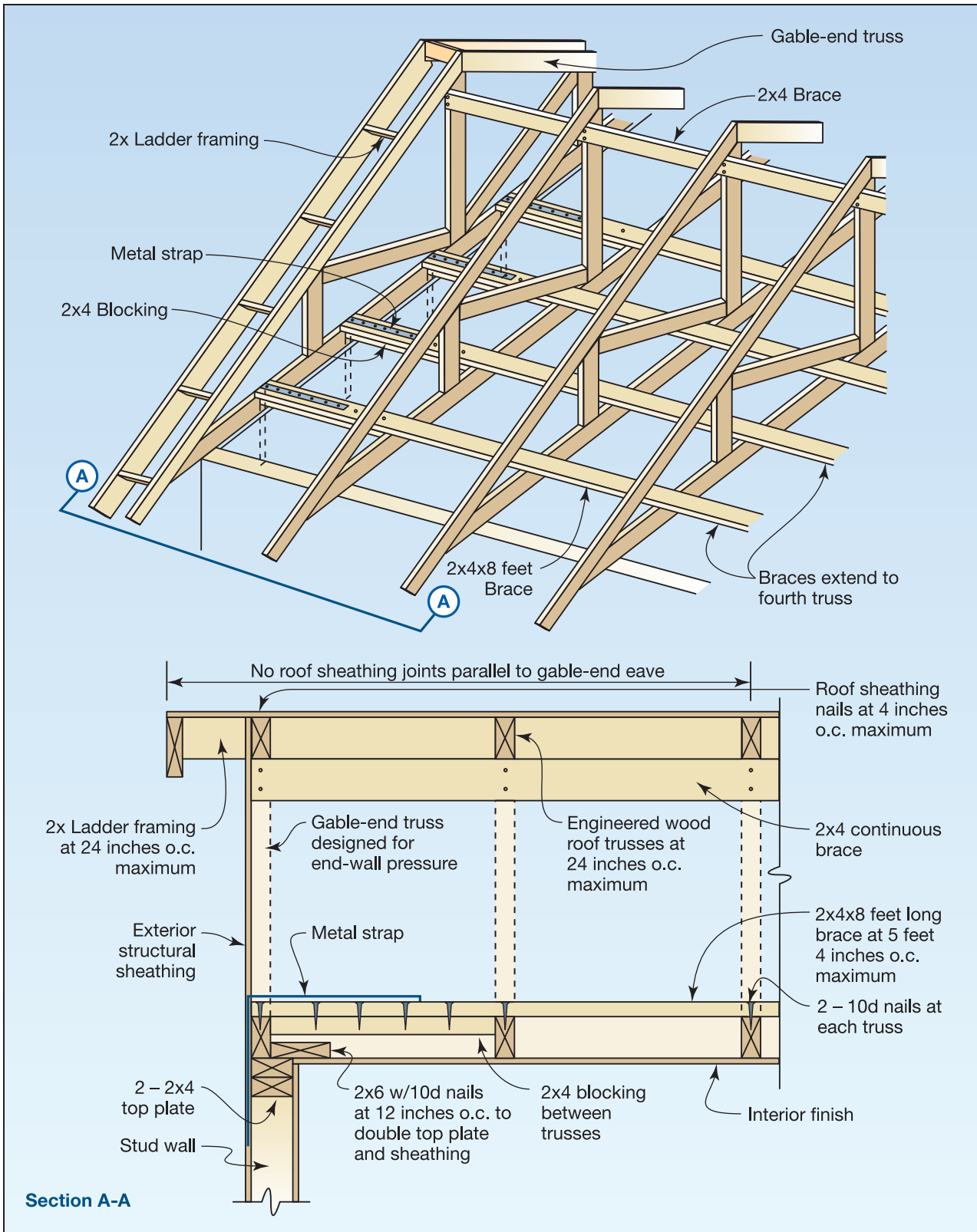

Figure 9-22. Gable-end bracing detail; nailing schedule, strap specification, brace spacing, and overhang limits should be adapted for the applicable basic wind speed

- Rated capacity of connector for all modes of failure (e.g., shear, uplift, gravity loading)
- Level of corrosion protection for nails, bolts, and/or screws
- Nail, bolt, and/or screw size and type required to achieve rated loads

### 9.2.4 Building Eccentricities

The L-shaped building configuration produces stress concentrations in the re-entrant corner of the building structure. Additionally, differences between the center of rotation and the center of mass produce torsional forces that must be transferred by the diaphragms and accounted for in the design of shear walls. Provisions for torsional response are different for wind and seismic hazards. Design methods to account for building eccentricities is beyond the scope of this Manual; therefore, the user is referred to building code requirements and provisions of ASCE 7-10 and applicable material design standards.

### 9.2.5 Framing System

Methods used for maintaining a load path throughout the structure depend on the framing system or structural system that makes up the building structure. Specifics related to platform framing, concrete/masonry construction, and moment-resistant framing are provided below.

#### 9.2.5.1 Platform Framing

Across the United States, platform framing is by far the most common method of framing a wood-stud or steel-stud residential building. In the platform framing method, a floor assembly consisting of beams, joists, and a subfloor creates a “platform” that supports the exterior and interior walls. The walls are normally laid out and framed flat on top of the floor, tilted up into place, and attached at the bottom to the floor through the wall bottom plate. The walls are attached at the top to the next-level floor framing or in a one-story building to the roof framing. Figure 9-23 is an example of platform framing in a two-story building. This method is commonly used on all types of foundation systems, including walls, piles, piers, and columns consisting of wood, masonry, and concrete materials. Less common framing methods in wood-frame construction are balloon framing in which wall studs are continuous from the foundation to the roof and post-and-beam framing in which a structure of beams and columns is constructed first, including the floors and roof, and then walls are built inside the beam and column structure.

#### 9.2.5.2 Concrete/Masonry

Masonry exterior walls are normally constructed to full height (similar to wood balloon framing), and then wood floors and the roof are framed into the masonry. Fully or partially reinforced and grouted masonry is required in high-wind and seismic hazard areas. Floor framing is normally supported by a ledger board fastened to a bond beam in the masonry, and the roof is anchored to a bond beam at the top of the wall. Connections can be via a top plate as shown in Figure 9-24 or direct embedded truss anchors in the bond beam as shown in



#### NOTE

Masonry frames typically require continuous footings. However, continuous footings are not allowed in Zone V or Coastal A Zones and are not recommended in Zone A.

Figure 9-23.  
Example of two-story  
platform framing on a  
pile-and-beam foundation

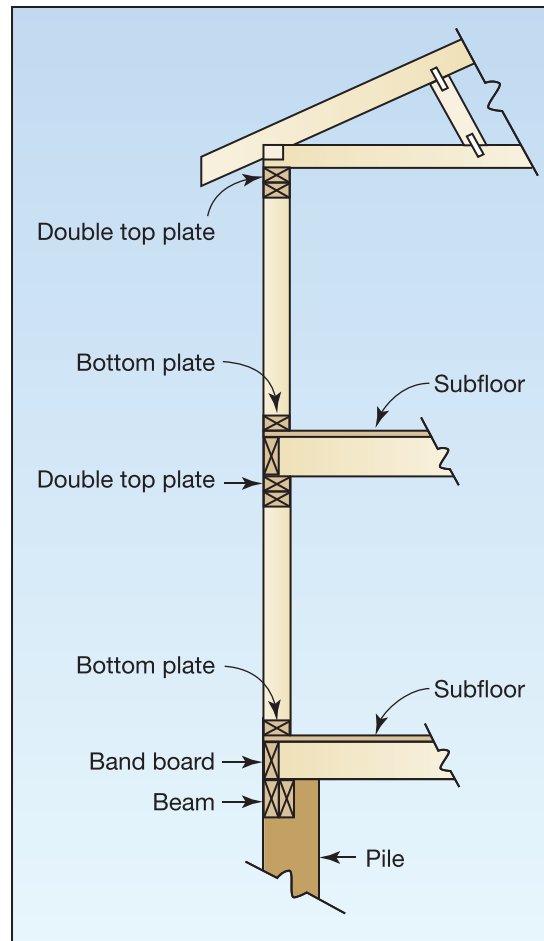

Figure 9-6. Options for end walls are hip roofs, continuous masonry gables, and braced gable frames. Details and design tables for all of the above can be found in ICC 600-2008. Figure 9-24 is an example of masonry wall construction in a two-story building.

### 9.2.5.3 Moment-Resisting Frames

Over the past few decades, an increasing number of moment-resisting frames have been built and installed in coastal homes (Hamilton 1997). The need for this special design is a result of more buildings in coastal high hazard areas being constructed with large glazed areas on exterior walls, with large open interior areas, and with heights of two to three stories. Figure 9-25 shows a typical steel moment frame.

Large glazed areas pose challenges to the designer because they create:

- Large openings in shear walls
- Large deflection in shear walls
- Difficulties in distributing the shear load to the foundation

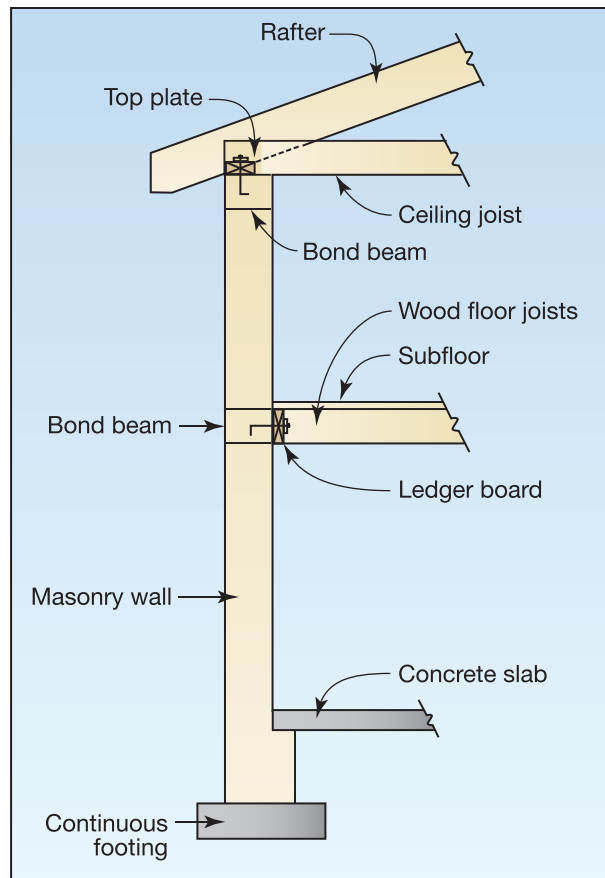

Figure 9-24.  
Two-story masonry wall  
with wood floor and roof  
framing



Figure 9-25.  
Steel moment frame with  
large opening



- A moment-resisting frame usually resists shear by taking the lateral load into the top of the frame thus creating a moment at the base of the frame. The design professional must design a moment connection at the base between the steel frame and the wood, masonry, or concrete foundation.

In residential construction, moment frames are frequently tubular steel. Tubular steel shapes that are close to the size of nominal framing lumber can be selected. This approach alleviates the need for special, time-consuming methods required to make the steel frame compatible with wood; however, frames made with tubular steel are more difficult to build than frames made with “H” or “WF” flange shapes because all connections in the frame are welded. There are a number of pre-manufactured moment frame products on the market now that have been designed for a variety of lateral forces to fit a variety of wall lengths and heights.

### 9.2.6 Roof Shape

Roof shape, both the structural aspect and the covering, plays a significant role in roof performance. Compared to other types of roofs, hip roofs generally perform better in high winds because they have fewer sharp corners and fewer distinctive building geometry changes. Steeply pitched roofs usually perform better than flat roofs. Figures 9-26 and 9-27 show two types of roofs in areas of approximately similar terrain that experienced the winds of Hurricane Marilyn. The gable roof in Figure 9-26 failed, while the hip roof in Figure 9-27 survived the same storm with little to no damage. Whether the roof is a gabled roof or hip roof, proper design and construction are necessary for successful performance in high-wind events.

## 9.3 Breakaway Wall Enclosures

In Zone V and Coastal A Zones, breaking waves are almost certain to occur simultaneously with peak flood conditions. As breaking waves pass an open piling or column foundation, the foundation experiences cyclic fluid impact and drag forces. The flow peaks at the wave crest, just as the wave breaks. Although the flow creates drag on the foundation, most of the flow under the building is undisturbed. This makes open foundations somewhat resistant to wave actions and pile and column foundations a manageable design.

When a breaking wave hits a solid wall, the effect is quite different. When the crest of a breaking wave strikes a vertical surface, a pocket of air is trapped and compressed by the wave. As the air pocket compresses, it exerts a high-pressure burst on the vertical surface, focused at the stillwater level. The pressures can be extreme. For example, a 5-foot wave height can produce a peak force of 4,500 pounds/square foot, roughly 100 times the force caused by a 170-mph wind. These extremely high loads make designing solid foundation walls for small buildings impractical in areas subject to the effects of breaking waves. Prudent design dictates elevating buildings on an open foundation above potential breaking waves. In fact, the 2012 IBC and the 2012 IRC require that new, substantially damaged, and substantially improved buildings in Zone V be elevated above the BFE on an open foundation (e.g., pile, post, column, pier).

The 2012 IBC and 2012 IRC prohibit obstructions below elevated buildings but allow enclosures below the BFE as long as they are constructed with insect screening, lattice, or walls designed and constructed to fail under the loads imposed by floodwaters (termed “breakaway walls”). Because such enclosures fail under flood forces, they do not transfer additional significant loads to the foundation. Regulatory requirements and design criteria concerning enclosures and breakaway walls below elevated buildings in Zone V are discussed in FEMA NFIP Technical Bulletin 9 (FEMA 2008a). Additional guidance is contained in Fact



Figure 9-26.  
Gable-end failure caused  
by high winds, Hurricane  
Marilyn (U.S. Virgin  
Islands, 1995)



Figure 9-27.  
Hip roof that survived  
high winds with little to  
no damage, Hurricane  
Marilyn (U.S. Virgin  
Islands, 1995)

Sheet No. 8.1, *Enclosures and Breakaway Walls* in FEMA P-499. Breakaway walls may be of wood- or metal-frame or masonry construction.

Figure 9-28 shows how a failure begins in a wood-frame breakaway wall. Note the failure of the connection between the bottom plate of the wall and the floor of the enclosed area. Figure 9-29 shows a situation in which utility components placed on and through a breakaway wall prevented it from breaking away cleanly.

To increase the likelihood of collapse as intended, it is recommended that the vertical framing members (such as 2x4s) on which the screen or lattice work is mounted be spaced at least 2 feet apart. Either metal or synthetic screening is acceptable. Wood and plastic lattice is available in 4-foot x 8-foot sheets. The material used to fabricate the lattice should be no thicker than 1/2 inch, and the finished sheet should have an opening ratio of at least 40 percent. Figure 9-30 shows lattice used to enclose an area below an elevated building.

**Figure 9-28.**  
Typical failure mode of breakaway wall beneath an elevated building—failure of the connection between the bottom plate of the wall and the floor of the enclosed area, Hurricane Hugo (South Carolina, 1989)



**Figure 9-29.**  
Breakaway wall panel prevented from breaking away cleanly by utility penetrations, Hurricane Opal (Florida, 1995)







Figure 9-30.  
Lattice beneath an  
elevated house in Zone V

## 9.4 Building Materials

The choice of materials is influenced by many considerations, including whether the materials will be used above or below the DFE. Below the DFE, design considerations include the risk of inundation by seawater, and the forces to be considered include those from wave action, water velocity, and waterborne debris impact. Materials intermittently wetted by floodwater below the BFE are subject to corrosion and decay.

Above the DFE, building materials also face significant environmental effects. The average wind velocity increases with height above ground. Wind-driven saltwater spray can cause corrosion and moisture intrusion. The evaporation of saltwater leaves crystalline salt that retains water and is corrosive.

Each type of commonly used material (wood, concrete, steel, and masonry) has both characteristics that can be advantageous and that can require special consideration when the materials are used in the coastal environment (see Table 9-1). A coastal residential structure usually has a combination of these materials.

Table 9-1. General Guidance for Selection of Materials

Material	Advantages	Special Considerations
<b>Wood</b>	<ul style="list-style-type: none"> <li>• Generally available and commonly used</li> <li>• With proper design, can generally be used in most structural applications</li> <li>• Variety of products available</li> <li>• Can be treated to resist decay</li> <li>• Some species are naturally decay-resistant</li> </ul>	<ul style="list-style-type: none"> <li>• Easily over-cut, over-notched, and over-nailed</li> <li>• Requires special treatment and continued maintenance to resist decay and damage from termites and marine borers</li> <li>• Requires protection to resist weathering</li> <li>• Subject to warping and deterioration</li> </ul>
<b>Steel</b>	<ul style="list-style-type: none"> <li>• Used for forces that are larger than wood can resist</li> <li>• Can span long distances</li> <li>• Can be coated to resist corrosion</li> </ul>	<ul style="list-style-type: none"> <li>• Not corrosion-resistant</li> <li>• Heavy and not easily handled and fabricated by carpenters</li> <li>• May require special connections such as welding</li> </ul>

Table 9-1. General Guidance for Selection of Materials (concluded)

Material	Advantages	Special Considerations
<b>Reinforced Concrete</b>	<ul style="list-style-type: none"> <li>Resistant to corrosion if reinforcing is properly protected</li> <li>Good material for compressive loads</li> <li>Can be formed into a variety of shapes</li> <li>Pre-stressed members have high load capacity</li> </ul>	<ul style="list-style-type: none"> <li>Saltwater infiltration into concrete cracks causes reinforcing steel corrosion</li> <li>Pre-stressed members require special handling</li> <li>Water intrusion and freeze-thaw cause deterioration and spalling</li> </ul>
<b>Masonry</b>	<ul style="list-style-type: none"> <li>Resistant to corrosion if reinforcing is properly protected</li> <li>Good material for compressive loads</li> <li>Commonly used in residential construction</li> </ul>	<ul style="list-style-type: none"> <li>Not good for beams and girders</li> <li>Water infiltration into cracks causes reinforcing steel corrosion</li> <li>Requires reinforcement to resist loads in coastal areas</li> </ul>

### 9.4.1 Materials Below the DFE

The use of flood-resistant materials below the BFE is discussed in FEMA NFIP Technical Bulletin 2 (FEMA 2008b). According to the bulletin, “All construction below the lowest floor is susceptible to flooding and must consist of flood-resistant materials. Uses of enclosed areas below the lowest floor in a residential building are limited to parking, access, and limited storage—areas that can withstand inundation by floodwater without sustaining significant structural damage.” The 2012 IBC and 2012 IRC require that all new construction and substantial improvements in the SFHA be constructed with materials that are resistant to flood damage. Compliance with these requirements in coastal areas means that the only building elements below the BFE are:

- Foundations – treated wood; concrete or steel piles; concrete or masonry piers; or concrete, masonry, or treated wood walls
- Breakaway walls
- Enclosures used for parking, building access, or storage below elevated buildings
- Garages in enclosures under elevated buildings or attached to buildings
- Access stairs

Material choices for these elements are limited to materials that meet the requirements provided in FEMA NFIP Technical Bulletin 2. Even for materials meeting those requirements, characteristics of various materials can be advantageous or may require special consideration when the materials are used for



#### NOTE

Although NFIP regulations, 2012 IBC, and 2012 IRC specify that flood-resistant materials be used below the BFE, in this Manual, flood-resistant materials below the DFE are recommended.



#### CROSS REFERENCE

For NFIP compliance provisions as described in the 2012 IBC and the 2012 IRC, see Chapter 5 of this Manual.



#### CROSS REFERENCE

For examples of flood insurance premiums for buildings in which the lowest floor is above the BFE and in which there is an enclosure below the BFE, see Table 7-2 in Chapter 7.



different building elements. Additional information about material selection for various locations and uses in a building is included in “Material Durability in Coastal Environments,” available on the Residential Coastal Construction Web site (<http://www.fema.gov/rebuild/mat/fema55.shtm>).

### 9.4.2 Materials Above the DFE

Long-term durability, architectural, and structural considerations are normally the most important factors in material selection. Material that will be used in a coastal environment will be subjected to weathering, corrosion, termite damage, and decay from water infiltration, in addition to the stresses induced by loads from natural hazard events. These influences are among the considerations for selecting appropriate materials. “Material Durability in Coastal Environments” contains additional information about a variety of wood products and the considerations that are important in their selection and use.

### 9.4.3 Material Combinations

Materials are frequently combined in the construction of a single residence. The most common combinations are as follows:

- Masonry or concrete lower structure with wood on upper level
- Wood piles supporting concrete pile caps and columns that support a wood superstructure
- Steel framing with wood sheathing

For the design professional working with of coastal buildings, important design considerations when combining materials include:

1. The compatibility of metals is a design consideration because dissimilar metals that are in contact with each other may corrode in the presence of salt and moisture. “Material Durability in Coastal Environments” addresses a possible problem when galvanized fasteners and hardware are in contact with certain types of treated wood.
2. Connecting the materials together is crucial. Proper embedment of connectors (if into concrete or masonry) and proper placement of connectors are necessary for continuity of the vertical or horizontal load path. Altering a connector location after it has been cast into concrete or grout is a difficult and expensive task.
3. Combining different types of material in the same building adds to construction complexity and necessitates additional skills to construct the project. Figure 9-31 shows a coastal house being constructed with preservative-treated wood piles that support a welded steel frame, resulting in metal coming into direct contact with treated wood.
4. Material properties, such as stiffness of one material relative to another, affect movement or deflection of one material relative to the other.

Figure 9-31.  
House being constructed  
with a steel frame on  
wood piles



#### 9.4.4 Fire Safety Considerations

Designing and constructing townhouses and low-rise multi-family coastal buildings to withstand natural hazards and meet the building code requirements for adequate fire separation presents some challenges. Although fire separation provisions of the 2012 IBC and 2012 IRC differ, they both require that the common walls between living units be constructed of materials that provide a minimum fire resistance rating. The intent is for units to be constructed so that if a fire occurs in one unit, the structural frame of that unit would collapse within itself and not affect either the structure or the fire resistance of adjacent units.

For townhouse-like units, the common framing method is to use the front and rear walls for the exterior load-bearing walls so that firewalls can be placed between the units. Beams that are parallel to the front and rear exterior walls are typically used to provide support for these walls as well as the floor framing. Figure 9-32 illustrates a framing system for a series of townhouses in which floor beams are perpendicular to the primary direction of flood forces. Design issues include the following:

5. The floor support beams are parallel to the shore and perpendicular to the expected flow and may therefore create an obstruction during a greater-than-design flood event.
6. The fire separation between townhouse units limits options for structural connections between units, making the transfer of lateral loads to the foundation more difficult to achieve.
7. The exposed undersides of buildings elevated on an open foundation (e.g., pile, pier, post, column) must be protected with a fire-rated material. Typically, this is accomplished with use of fire-resistant gypsum board; however, gypsum board is not a flood-damage-resistant material. An alternative approach is to use other materials such as cement-fiber board (with appropriate fire rating), which has a greater resistance to damage from floodwaters, and fire retardant treated wood. Other alternative materials or methods of protection that are flood-damage-resistant may be required in order to meet the competing demands of flood- and fire-resistance.

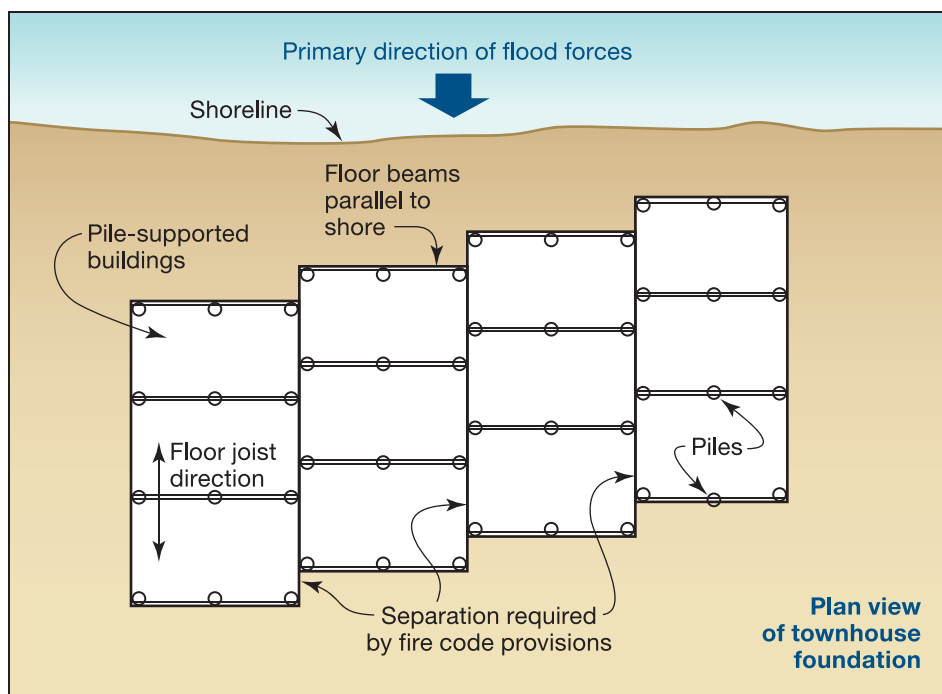

Figure 9-32.  
Townhouse framing  
system

8. The requirement for separation of the foundation elements between townhouse units makes structural rigidity in the direction parallel to the shore more difficult to achieve. If the houses in Figure 9-32 were in a seismic hazard area, the designer could decide to place diagonal bracing parallel to the shore (i.e., perpendicular to the primary flood flow direction) or use more closely spaced and larger piles. Diagonal bracing would provide rigidity but would also create an obstruction below the DFE. The design professional should consult FEMA NFIP Technical Bulletin 5 (FEMA 2008c) for information about the types of construction that constitute an obstruction.

One solution to some of the issues illustrated by Figure 9-32 would be to use two parallel independent walls to provide the required fire separation between units. Each wall could be attached to the framing system of the unit on one side of the separation and supported by a beam running perpendicular to the shore and bearing on the open foundation of that unit.

### 9.4.5 Corrosion

Modern construction techniques often rely heavily on metal fasteners and connectors to resist the forces of various coastal hazards. To be successful, these products must have lifetimes that are comparable to those of the other materials used for construction. Near saltwater coastlines, corrosion has been found to drastically shorten the lifetime of standard fasteners and connectors. Corrosion is one of the most underestimated hazards affecting the overall strength and lifetime of coastal buildings. To be successful, hazard-resistant buildings must match the corrosion exposure of each element with the proper corrosion-resistant material.



#### CROSS REFERENCE

For additional information about corrosion of metal connectors in coastal construction, see FEMA NFIP Technical Bulletin 8-96.

## 9.5 Appurtenances

The NFIP regulations define “appurtenant structure” as “a structure which is on the same parcel of property as the principal structure to be insured and the use of which is incidental to the use of the principal structure” (44 CFR § 59.1). In this Manual, “appurtenant structure” means any other building or constructed element on the same property as the primary building, such as decks, covered porches, access to elevated buildings, pools, and hot tubs.



### CROSS REFERENCE

For additional information about the types of building elements that are allowed below the BFE and for respective site development issues, see FEMA NFIP Technical Bulletin 5.

### 9.5.1 Decks and Covered Porches Attached to Buildings

Many decks and other exterior attached structures have failed during hurricanes. For decks and other structures without roofs, the primary cause of failure has been inadequate support: the pilings have either not been embedded deep enough to prevent failure or have been too small to carry the large forces from natural hazards.

The following are recommendations for designing decks and other exterior attached structures:

- If a deck is structurally attached to a structure, the bottom of the lowest horizontal supporting member of the deck must be at or above the BFE. Deck supports that extend below the BFE (e.g., pilings, bracing) must comply with Zone V design and construction requirements. The structure must be designed to accommodate any increased loads resulting from the attached deck.
- Some attached decks are located above the BFE but rely on support elements that extend below the BFE. These supports must comply with Zone V design and construction requirements.
- If a deck or patio (not counting its supports) lies in whole or in part below the BFE, it must be structurally independent from the structure and its foundation system.
- If the deck surface is constructed at floor level, the deck surface/floor level joint provides a point of entry for wind-driven rain. This problem can be eliminated by lowering the deck surface below the floor level.
- If deck dimensions can be accommodated with cantilevering from the building, this eliminates the need for piles altogether and should be considered when the deck dimensions can be accommodated with this structural technique. Caution must be exercised with this method to keep water out of the house framing. Chapter 11 discusses construction techniques for flashing cantilever decks that minimize water penetration into the house.
- Exposure to the coastal environment is severe for decks and other exterior appurtenant structures. Wood must be preservative-treated or naturally decay resistant, and fasteners must be corrosion resistant.



### WARNING

Decks should not cantilever over bulkheads or retaining walls where waves can run up the vertical wall and under the deck.

### 9.5.1.1 Handrails

To minimize the effects of wind pressure, flood forces, and wave impacts, deck handrails should be open and have slender vertical or horizontal members spaced in accordance with the locally adopted building code. Many deck designs include solid panels (some made of impact-resistant glazing) between the top of the deck handrail and the deck. These solid panels must be able to resist the design wind and flood loads (below the DFE) or they will become debris.

### 9.5.1.2 Stairways

Many coastal homes have stairways leading to ground level. During flooding, flood forces often move the stairs and frequently separate them from the point of attachment. When this occurs, the stairs become debris and can cause damage to nearby houses and other buildings. Recommendations for stairs that descend below the BFE include the following:

- To the extent permitted by code, use open-riser stairs to let floodwater through the stair stringers and anchor the stringers to a permanent foundation by using, for example, piles driven to a depth sufficient to prevent failure from scour.
- Extend the bottom of the stair carriages several feet below grade to account for possible scour. Stairs constructed in this fashion are more likely to remain in place during a coastal hazard event and therefore more likely to be usable for access after the event. In addition, by decreasing the likelihood of damage, this approach reduces the likelihood of the stairs becoming debris.

## 9.5.2 Access to Elevated Buildings

The first floor of buildings in the SFHA is elevated from a few feet to many feet above the exterior grade in order to protect the building and its contents from flood damage. Buildings in Zone A may be only a few feet above grade; buildings in Zone V may be 8 feet to more than 12 feet above grade. Access to these elevated buildings must be provided by one or more of the following:

- Stairs
- Ramps
- Elevator

Stairs must be constructed in accordance with the local building code so that the run and rise of the stairs conform to the requirements. The 2012 IBC and 2012 IRC require a minimum run of 11 inches per stair tread and a maximum rise of 7 inches per tread. An 8-foot elevation difference requires 11 treads or almost 12 feet of horizontal space for the stairs. Local codes also have requirements concerning other stair characteristics, such as stair width and handrail height.

Ramps that comply with regulations for access by persons with disabilities must have a maximum slope of 1:12 with a maximum rise of 30 inches and a maximum run of 30 feet without a level landing. The landing length must be a minimum of 60 inches. As a result, access ramps are generally not practical for buildings elevated more than a few feet above grade and then only when adequate space is available.



Elevators are being installed in many one- to four-family residential structures and provide an easy way to gain access to elevated floors of a building (including the first floor). There must be an elevator entrance on the lowest floor; therefore, in flood hazard areas, some of the elevator equipment may be below the BFE. FEMA's NFIP Technical Bulletin 4 (FEMA 2010a) provides guidance on how to install elevators so that damage to elevator elements is minimized during a flood.



### CROSS REFERENCE

For more information about elevator installation in buildings located in SFHAs, see FEMA NFIP Technical Bulletin 4.

### 9.5.3 Pools and Hot Tubs

Many homes at or near the coast have a swimming pool or hot tub as an accessory. Some of the pools are fiberglass and are installed on a pile-supported structural frame. Others are in-ground concrete pools. The design professional should consider the following when a pool is to be installed at a coastal home:

- Only an in-ground pool may be constructed beneath an elevated Zone V building. In addition, the top of the pool and the accompanying deck or walkway must be flush with the existing grade, and the area below the lowest floor of the building must remain unenclosed.
- Enclosures around pools beneath elevated buildings constitute recreational use and are therefore not allowed, even if constructed to breakaway standards. Lattice and insect screening are allowed because they do not create an enclosure under a community's NFIP-compliant floodplain management ordinance or law.
- A pool adjacent to an elevated Zone V building may be either constructed at grade or elevated. Elevated pools must be constructed on an open foundation and the bottom of the lowest horizontal structural member must be at or above the DFE so that the pool will not act as an obstruction.
- The designer must assure community officials that a pool beneath or adjacent to an elevated Zone V building will not be subject to breaking up or floating out of the ground during a coastal flood and will therefore not increase the potential for damage to the foundations and elevated portions of any nearby buildings. If an in-ground pool is constructed in an area that can be inundated by floodwaters, the elevation of the pool must account for the potential buoyancy of the pool. If a buoyancy check is necessary, it should be made with the pool empty. In addition, the design professional must design and site the pool so that any increased wave or debris impact forces will not affect any nearby buildings.



### NOTE

Check with local floodplain management officials for information about regulations governing the disturbance of primary frontal dunes. Such regulations can affect various types of coastal construction, including the installation of appurtenant structures such as swimming pools.



### NOTE

The construction of pools below or adjacent to buildings in coastal high hazard areas must meet the requirements presented in FEMA NFIP Technical Bulletin 5. In general, pools must be (1) elevated above the BFE on an open foundation or (2) constructed in the ground in such a way as to minimize the effects of scour and the potential for the creation of debris.

- Pools and hot tubs have water pumps, piping, heaters, filters, and other equipment that is expensive and that can be damaged by floodwaters and sediment. All such equipment should be placed above the DFE where practical.
- Equipment required for fueling the heater, such as electric meters or gas tanks, should be placed above the DFE. It may also be necessary to anchor the gas tank to prevent a buoyancy failure.
- If buried, tanks must not be susceptible to erosion and scour and thus failure of the anchoring system.

The design intent for concrete pools includes the following:

- Elevation of an in-ground pool should be such that scour will not permit the pool to fail from either normal internal loads of the filled pool or from exterior loads imposed by the flood forces.
- The pool should be located as far landward as possible and should be oriented in such a way that flood forces are minimized. One way to minimize flood forces includes placing the pool with the narrowest dimension facing the direction of flow, orienting the pool so there is little to no angle of attack from floodwater, and installing a pool with rounded instead of square corners. All of these design choices reduce the amount of scour around the pool and improve the chances the pool will survive a storm. These concepts are illustrated in Figure 9-33.
- A concrete pool deck should be frangible so that flood forces create concrete fragments that help reduce scour. The concrete deck should be installed with no reinforcing and should have contraction joints placed at 4-foot squares to “encourage” failure. See Figure 9-34 for details on constructing a frangible concrete pad.
- Pools should not be installed on fill in or near Zone V. Otherwise, a pool failure may result from scour of the fill material.

For concrete pools, buoyancy failure is also possible when floodwaters cover the pool. In addition, flood flows can scour the soil surrounding a buried pool and tear the pool from its anchors. When this happens, the pieces of the pool become large waterborne debris.

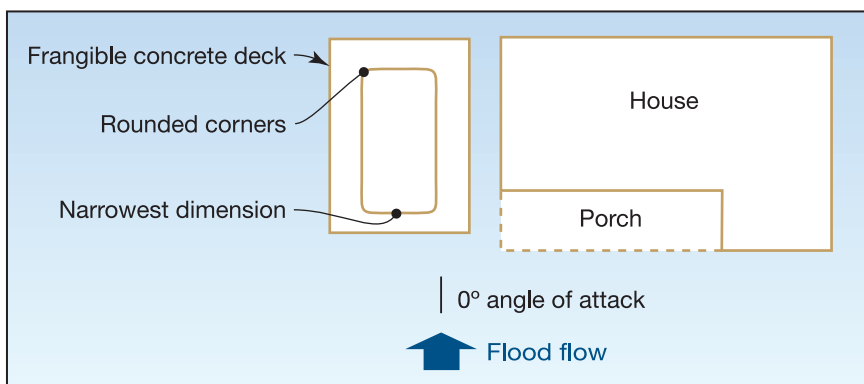

**Figure 9-33.**  
Recommendations for  
orientation of in-ground  
pools

Figure 9-34.  
Recommended  
contraction joint layout  
for frangible slab-on-  
grade below elevated  
building

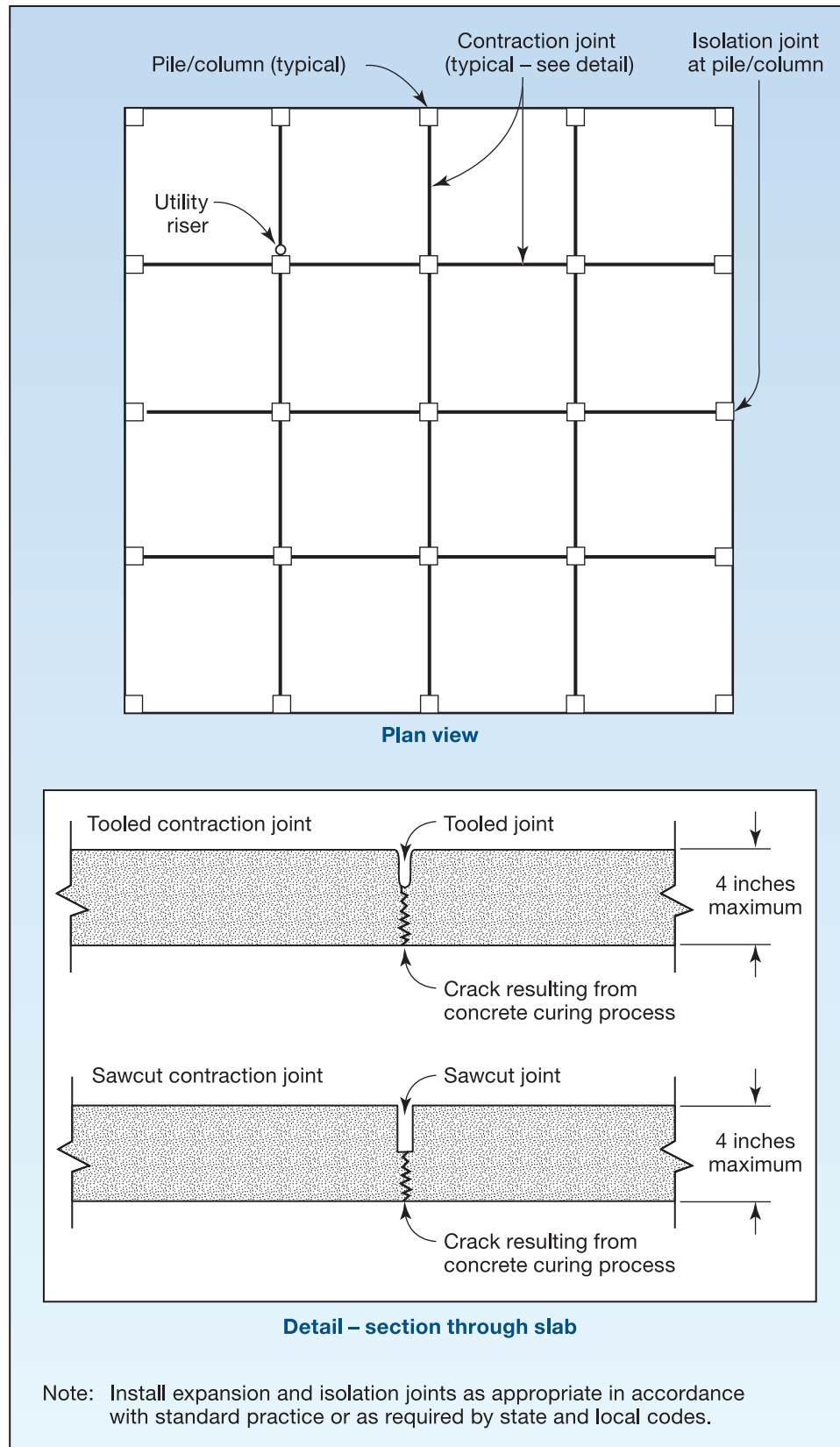

## 9.6 References

- AF&PA (American Forest & Paper Association ). 2008. *Special Design Provisions for Wind and Seismic*. ANSI/AF&PA SDPWS-08.
- AF&PA. 2012. *Wood Frame Construction Manual for One- and Two-Family Dwellings*. Washington, DC.
- ASCE (American Society of Civil Engineers). 2010. *Minimum Design Loads for Buildings and Other Structures*, ASCE Standard ASCE 7-10.
- AWC (American Wood Council). 2001. *Wood Frame Construction Manual*.
- AWC. 2006. *National Design Specification for Wood Construction (NDS)*.
- FEMA (Federal Emergency Management Agency). 1996. *Corrosion Protection of Metal Connectors in Coastal Areas for Structures Located in Special Flood Hazard Areas*. NFIP Technical Bulletin 8-96.
- FEMA. 2008a. *Design and Construction Guidance for Breakaway Walls Below Elevated Coastal Buildings*, FEMA NFIP Technical Bulletin 9.
- FEMA. 2008b. *Flood Damage-Resistant Materials Requirements*, FEMA NFIP Technical Bulletin 2.
- FEMA. 2008c. *Free of Obstruction Requirements for Buildings Located in Coastal High Hazard Areas*. NFIP Technical Bulletin 5.
- FEMA. 2009. *Local Officials Guide for Coastal Construction*. FEMA 762.
- FEMA. 2010a. *Elevator Installation for Buildings Located in Special Flood Hazard Areas in accordance with the National Flood Insurance Program*. NFIP Technical Bulletin 4.
- FEMA. 2010b. *Home Builder's Guide to Coastal Construction Technical Fact Sheets*. FEMA P-499.
- Hamilton, P. 1997. "Installing a Steel Moment Frame." *Journal of Light Construction*. March.
- ICC (International Code Council). 2008. *Standard for Residential Construction in High-Wind Regions*. ICC 600-2008. ICC: Country Club Hills, IL.
- ICC. 2011a. *International Building Code*. 2012 IBC. ICC: Country Club Hills, IL.
- ICC. 2011b. *International Residential Code for One-and Two-Family Dwellings*. 2012 IRC. ICC: Country Club Hills, IL.
- WPPC (Wood Products Promotion Council). 1996. *Guide to Wood Construction in High Wind Areas*.